

**Compressed Voice/Fax Card
Operation Manual**
Channel Card for the Series KMX 9000 Multiplexers

© Case Communications Ltd 1997

STATUTORY NOTICES

WARNINGS

WARNING: Inter-connection directly, or by way of other apparatus, of ports marked:

"WARNING

Connect only apparatus complying with BS6301 to this (or these) port(s)"

or

"WARNING

Connect only apparatus complying with BS6301 to this (or these) port(s) unless connection is made to a telecommunications network."

or

"SAFETY WARNING. See instructions for use."

with ports not so marked may produce hazardous conditions on the telecommunications network. Advice should be obtained from a competent engineer before such a connection is made.



Case Communications Ltd declare that this product conforms with the protection requirements of Council Directive 89/336/EEC on the approximation of the laws of the member states relating to electromagnetic protection.

This equipment has been tested using shielded cables supplied by Case Communications Ltd. These cables, or equivalents, must be used to ensure compliance with this declaration.

All PCB assemblies contain Electrostatic Sensitive Devices (ESDs) which may be permanently damaged if incorrectly handled. This equipment must be handled in accordance with BS5783 code of practice for the handling of electrostatic sensitive devices.

Case Communications Limited has made all reasonable efforts to ensure the accuracy of the content of this document but the information contained herein does not constitute a warranty of performance of the equipment and/or software described and no specifications given form part of any contract. This document does not constitute a licence to use or copy any software described herein and any such software must only be used in accordance with the terms of the licence supplied herewith.

Case Communications Limited reserves the right to make alterations to the equipment and software described without notice and assumes no liability for any loss or damage caused as a result of use of this document whether because of out of date or inaccurate information or otherwise.

Product and manufacturers' names referred to in this document are used for identification purposes only and Case Communications Limited acknowledges the intellectual property rights of their respective owners in the same.

This document is the copyright of Case Communications Limited and may not be reproduced, copied or stored in any computerised retrieval system by any means without the express written permission of Case Communications Limited.

Published by Case Communications Technical Publications Department

STATUTORY NOTICES

APPROVALS

The Approval Numbers are:

TVF and ETVF: NS/1282/2/P/603733
QVF and EQVF NS/1282/2/P/603734

The voice ports are approved for direct connection as the following port types:

The voice ports are approved for indirect connection to speechband private circuits. Approval was granted on the basis of testing to port type 5A (two wire) and port type 5B (four wire), as defined in OTR/001.

These cards are intended for use in the Case Communications KMX9000 series chassis. Other usage will invalidate any approval given to these cards, if as a result they cease to comply with BS6301; 1989.

The safety status of the backplane port is SELV.

The safety status of the network ports is TNV.

Unused voice ports must be fitted with a protective cover, part No. 1050-001 which is available from Case Communications or other suitable cover.

The voice ports may not be connected to wiring which would be required by BS6701:part 1:1986 to be equipped with over-voltage protection.

If the card(s) are not installed in a Case Communications Series KMX 9000 chassis the following conditions must be met to maintain their approval:

- Ensure that the power drawn by the card(s), together with the chassis and any auxiliary equipment drawing power from the chassis, is within the rating of the chassis power supply. (Refer to the Power Consumption Table in the Series KMX 9000 Multiplexer Reference Manual part number X729-300051.)
- Install the card so that, with the exception of the chassis bus connector, clearance and creepage distances shown in the table below are maintained between the module and all other parts of the chassis which use or generate a voltage shown in the table; the creepage distance shown in brackets applies where the local environment within the chassis is subject to conductive pollution or dry non-conductive pollution which could become conductive due to condensation.

Clearance (mm)	Creepage (mm)	Voltage used or generated by host or other cards
2.0	2.4 (3.8)	Up to 50 Vrms or Vdc
2.6	3.0 (4.8)	Up to 125 Vrms or Vdc
4.0	5.0 (8.0)	Up to 250 Vrms or Vdc
4.0	6.4 (10.0)	Up to 300 Vrms or Vdc

- For a chassis using or generating voltages greater than 300 V (rms or dc), you must obtain advice from a competent telecommunications safety engineer before installing the modules.

Contents

1	General Description	7
2	Specifications	8
3	Card Restrictions	12
4	Hardware Configuration	13
4.1	Links and Switches	13
4.2	LED Indicators	14
5	Software Configuration	18
5.1	Adding a New Channel	18
5.2	Channel Data Rate	19
5.3	Remote Channel Address	19
5.4	Channel Maximum Input Level	20
5.5	Channel Output Gain	20
5.6	Pulse Rate	21
5.7	Make/Break Ratios	21
6	Diagnostics	24
6.1	Channel Loopback Tests	24
6.2	Setting a Channel Loopback	25
7	Channel Interface I/O Connections	26
8	Interface Connecting Cables	27

Figures

1-1	TVF & ETVF Switch and F/W Positions	16
1-2	QVF & EQVF Switch and F/W Positions	17

Compressed Voice/Fax Card

1. General Description

The TVF and QVF, and the enhanced versions ETVF and EQVF, are channel interface cards for installation in the Series KMX 9000 range of TDM multiplexers. This manual assumes that you are familiar with the control of the Series 9000 multiplexers and installation procedures for channel cards. This manual applies to cards fitted in Series KMX 9000 multiplexers with TLM/QLM firmware V3.1 or later. Refer to the Series KMX 9000 multiplexer manual (part number X729-300051) for further details.

The card is available in either Twin or Quad format and is described as a Twin Compressed Voice/Fax (TVF) card or a Quad Compressed Voice/Fax (QVF) card and as such provides two or four 2/4 wire compressed voice channels using the CELP algorithm which provide transmission of AC15A signalling and Group 3 facsimile. E & M signalling is also supported. The compression can be either to 9.6kbps, 6.4kbps or 4.8kbps depending on the card type. The TVF and QVF provide compression at 4.8kbps and 6.4kbps while the ETVF and EQVF provide compression at 6.4kbps and 9.6kbps.

The cards can be used to provide inter PABX connection for both E & M signalling and AC15A signalling and can be used to convert E & M signalling at one end to AC15A signalling at the other end.

The available channels will be described as LBFX (Low Bit Rate Fax) channels in the configuration menu.

2. Specifications

The TVF and ETVF cards support two compressed voice channels.
The QVF and EQVF cards support four compressed voice channels.

Analogue Channel Delay

The delay from the analogue V.F. input to the backplane is 40ms. The delay from the backplane to the analogue V.F. output is 40ms. These delays must be added to those of the DCC, if used, and aggregate link module when calculating overall end to end delays.

Analogue Interface

Transformer coupled, four wire, with a nominal impedance of 600 ohms; or two wire matched to 600 ohms or the impedance reference network as specified in BS 6305 figure 5. Transformers conform to BS6301 for safety.

Signalling Interface

E & M signalling in accordance with SSDC5.

AC15 2280 Hz pulse tone signalling in accordance with SSAC15A.

AC15 to E & M signal conversion with 9.6kbps, 6.4kbps and 4.8kbps speech.

Transparent DTMF signalling.

Signalling Distortion

Signalling information is transmitted within the TDM supervisory channel. The dial pulse strings are sampled, transmitted and re-timed with a pulse rate of 10pps and a make:break ratio of 34:66, 40:60 or 50:50. Other rates and ratios can be incorporated.

E & M pulse widths and AC15 2280Hz tone pulse widths are handled by the CVC (Compressed Voice Card) receiver as follows:

1. All pulses greater than 10ms are passed.
2. Make/break pulse tolerance is $\pm 20\%$ of the nominal value (e.g. $\pm 20\%$ of 34 ms make pulse).
3. Minimum inter digit pause = 230ms.
4. Minimum clear down = 230ms
5. Pulses between 10ms and 228ms that are not either a make or break pulse are transmitted transparently.

E & M pulse widths and AC15 2280Hz Tone Pulse Widths are dialled out by the CVC as follows:

1. Make/break pulses are dialled out at their nominal value (e.g. 34:66).
2. Inter digit pause = 800ms (min).
3. Clear down = 300ms (min).

Voice Encoding Technique

VQ-CELP (Vector Quantised - Codebook Excited Linear Predictive).

Data Voice Rate

Software selectable to be:	ETVF/EQVF	9600bps or 6400bps.
	TVF/QVF	6400bps or 4800bps.

Maximum Input Level

Software selectable to be +6, +3, 0, or -3dBm.

Output Gain

Software selectable to be +3, 0, -3, or -6dB.

Overall Channel Gain

The end to end gain for an individual voice channel circuit is calculated using the following formula:

Channel gain (dB) = Output gain - Maximum input level (dBm)

Channel Busy Out

A voice channel will busy out by automatically earthing the 'M' lead output if:

- a) power is lost.
- or b) the channel is not configured.
- or c) reliable communications with the remote voice channel cannot be maintained.

Voice Distortion

3 qdu @ 9600 bps)

5 qdu @ 6400 bps) Estimates; subject to CCITT ratification.

7 qdu @ 4800 bps)

Fax

The EQVF and ETVF cards supports 'Group 3 Fax' which is automatically detected, demodulated and carried to the remote end digitally for regeneration. After call clear down, the card will default to compressed voice operation.

Fax operation is supported when set to 9.6kbps or 6.4kbps.

When operating on a 9.6kbps speech channel, the ETVF and EQVF support:

- Group 3 fax machines with V.29 and V.27ter image transfer capabilities.
- Fax operation according to the ITU-T T.30 (1988) protocol with 300bps V.21 channel 2 signalling and V.29 image transfer at 9600bps and 7200bps.
- Fax operation according to the ITU-T T.30 (1988) protocol with 300bps V.21 channel 2 signalling and V.27ter image transfer at 4800bps and 2400bps.
- The optional T.30 error correction mode of operation.
- Automatic support of fax fallback speeds, without need to change speech channel speed.
- Support of standard (100 x 200 dpi) and fine (200 x 200 dpi) resolution for fax transmission.

When operating on a 6.4kbps speech channel, the ETVF and EQVF support:

- Group 3 fax machines with V.29 and V.27ter image transfer capabilities.
- Fax operation according to the ITU-T T.30 (1988) protocol with 300bps V.21 channel 2 signalling and V.27ter image transfer at 4800bps and 2400bps.
- Automatic support of fax fallback speeds, without need to change speech channel speed.

Support of standard (100 x 200 dpi) and fine (200 x 200 dpi) resolution for fax transmission.

The ETVF and EQVF cards will not support:

- Proprietary or non-standard feature operation, allowed via the NSF frame within T.30.
- 2400bps binary coded signalling.
- T.2 (Group 1) and T.3 (Group 2) operation.
- Tandem links that have satellite delay in both legs of the tandem link.

Diagnostic Loopbacks

The cards can be software controlled to provide loops on all available voice channels. Loops can be applied or removed individually on a channel by channel basis. The channel loop provided is digital and bi-directional. Loopbacks should be used with care as feedback 'howl' is likely to occur in both 2- and 4-wire analogue interfaces.

Echo cancellers are not disengaged when loopbacks are activated, and hence continuous tone testing of a looped circuit will not result in the reflection of clean tones. If AC15 signalling is used and a channel loopback is applied, the 2280Hz output tone will be distorted.

E and M signalling is not looped back.

When a fax channel is placed into a loopback condition, fax transmission and reception will fail, i.e. it is not possible to utilise the channel loopback to check the integrity of the fax transmission.

Environmental

Operating Temperature	+5°C to +40°C
Storage Temperature	-25°C to +55°C
Humidity	5 to 95% non-condensing

Weight

TVF and ETVF:	850g
QVF and EQVF:	1075g

MTBF (Calculated to HRD4)

TVF and ETVF:	24 years
QVF and EQVF:	14.8 years

Power Consumption

TVF and ETVF:	8.3 W
QVF and EQVF:	15.1 W

3. Card Restrictions

The configuration and application/removal of loopbacks on the cards can be carried out from the front panel.

The cards support both E & M type inter-PBX signalling and AC15A inter PBX signalling. It will also convert AC15 signalling at one end into E & M signalling at the other end. Other inter-PBX or telephony signalling types are not directly supported, however it may be possible to use signalling converters to convert an unsupported signalling type to a type that is supported.

The 'Busy Out' condition and the inter-PBX signalling type is selected from a switchbank located at the front of the card. This is not accessible when the card is installed in the 9220/9240 chassis.

Features normally associated with a specific fax machine manufacturer or model (NSF Non Standard Features) are not supported. Any NSF requests are absorbed by the card and are not transmitted to the remote fax machine.

Fax T30 protocol transfers at 2400bps are not supported. All T30 protocol transfers will be forced to operate at 300bps.

Operation over satellite circuits is possible with certain fax machines only, this is due to the nature of T30 inter-protocol timeouts allowed in the CCITT recommendation.

Tandem fax operation (i.e. circuits involving two A/D and D/A CELP encodings) will need to be verified on a machine by machine basis. This should be organised via your supplier.

Tandem voice operation is not recommended at 6.4k and 4.8k rates.

4. Hardware Configuration

The cards contain processor, memory interfaces etc. for two or four low bit rate voice channels. Each channel is presented to the TLM/QLM as a single synchronous channel.

Note: When using cable 1542/005 please ensure that the flying earth lead, attached to the cable, is secured to the earth stud located on the rear of the KMX 9000 chassis.

4.1 Links and Switches

The (E)TVF has three switches: SW1, S100 and S200. The (E)QVF has five switches: SW1, S100, S200, S300 and S400. (Refer to Figures 1-1 and 1-2).

The analogue interface of the compressed voice card can be configured for 2- or 4-wire operation. In addition, the line termination impedance can be selected for class 'b' return loss, giving compatibility with 600 ohm systems, or for class 'a' return loss, giving compatibility with systems employing the impedance reference network as specified in BS 6305, fig. 5.

Selection of these features is facilitated by DIL switch blocks located towards the rear of the module: S100 (channel 1), S200 (channel 2), S300 (channel 3) and S400 (channel 4). Each DIL switch block contains two positions, one marked 2W/4W (2-wire or 4-wire) and the other marked 600/NET (600 ohms or complex impedance termination). Each switch should be configured to match the analogue equipment (e.g. PABX) connected to the voice channel. For 4-wire operation 600 ohm termination must always be selected. In 2-wire applications the termination impedance can be either, however as a general rule, modern digital PABXs use the complex impedance termination while older types use 600 ohms: if in doubt contact the PABX supplier for information. For two wire operation the analogue pair is presented on the 4-wire analogue input pins of the 15-way interface connector (pins 1 and 2).

Do not attempt to adjust these switches in a live system. Always disconnect the 15-way connector from the card interface and remove power before making physical contact with the switches.

Gain settings are controlled by the front panel keypad .

The cards have a 4-way DIL switch (SW1) mounted on the front edge of the board to the right of the group of LED indicators. The DIL switch functions are as follows:

SW1.1- This switch controls the busy out enable/disable facility and as such determines the final state of the relative M lead(s) when a channel or channels have been busied out. SW1.1 affects ALL of the available channels and is configured in the following manner:

OFF = Earth-off Busy - all channels with E & M signalling selected will have an earth off (on hook) condition applied to the M lead(s) of the relative channel(s) until the busy out is cleared.

ON = Earth-on Busy - all channels with E & M signalling selected will have an earth on condition (off hook) applied to the M lead(s) of the relative channel(s) until the busy out is cleared.

SW1.1 has no effect on any channel with 2280Hz tone signalling selected, since a busy out is only applied when a channel or channels experience high error rates. A side effect of this is that the voice compression circuit mutes the voice output due to the errors therefore no 2280Hz tone is present (off -hook condition) irrespective of the configuration of SW1.1.

SW1.2, 3 and 4 - These three switches select E & M or 2280Hz TONE signalling for the available channels and are configured as follows:

OFF = 2280Hz Tone signalling selected.

ON = E & M signalling selected.

The channel assignment for these switches is as follows:

SW1.2 = 2280Hz Tone/E & M signalling selected for channel 1

SW1.3 = 2280Hz Tone/E & M signalling selected for channel 2

SW1.4 = 2280Hz Tone/E & M signalling selected for channels 3 and 4

SW1.4 controls channels 3 and 4. If the board is a (E)TVF with only two channels available, SW1.4 will have no effect.

IMPORTANT: SW1 is only read once at power up. Once the board has initialised, any changes in the configuration of SW1 will have no effect until the CPU is reset by applying a power down/up.

4.2 LED Indicators

The (E)QVF has 9 front panel LED status indicators and the (E)TVF has 5.

- E1 when illuminated indicates a busy condition on the E lead input to voice channel 1.
- M1 when illuminated indicates a busy condition on the M lead output from voice channel 1.
- E2 when illuminated indicates a busy condition on the E lead input to voice channel 2.
- M2 when illuminated indicates a busy condition on the M lead output from voice channel 2.
- E3 when illuminated indicates a busy condition on the E lead input to voice channel 3.
- M3 when illuminated indicates a busy condition on the M lead output from voice channel 3.
- E4 when illuminated indicates a busy condition on the E lead input to voice channel 4.
- M4 when illuminated indicates a busy condition on the M lead output from voice channel 4.
- TF/QF indicates card type i.e. TF for TVF or QF for QVF.
- ET/EQ indicates card type i.e. ET for ETVF or EQ for EQVF.

This green indicator should be permanently illuminated if the card is inserted, power is applied and power on diagnostics are successful. This indicator will flash if diagnostics fail.

Indicators E3, M3, E4 and M4 are not fitted on the (E)TVF.

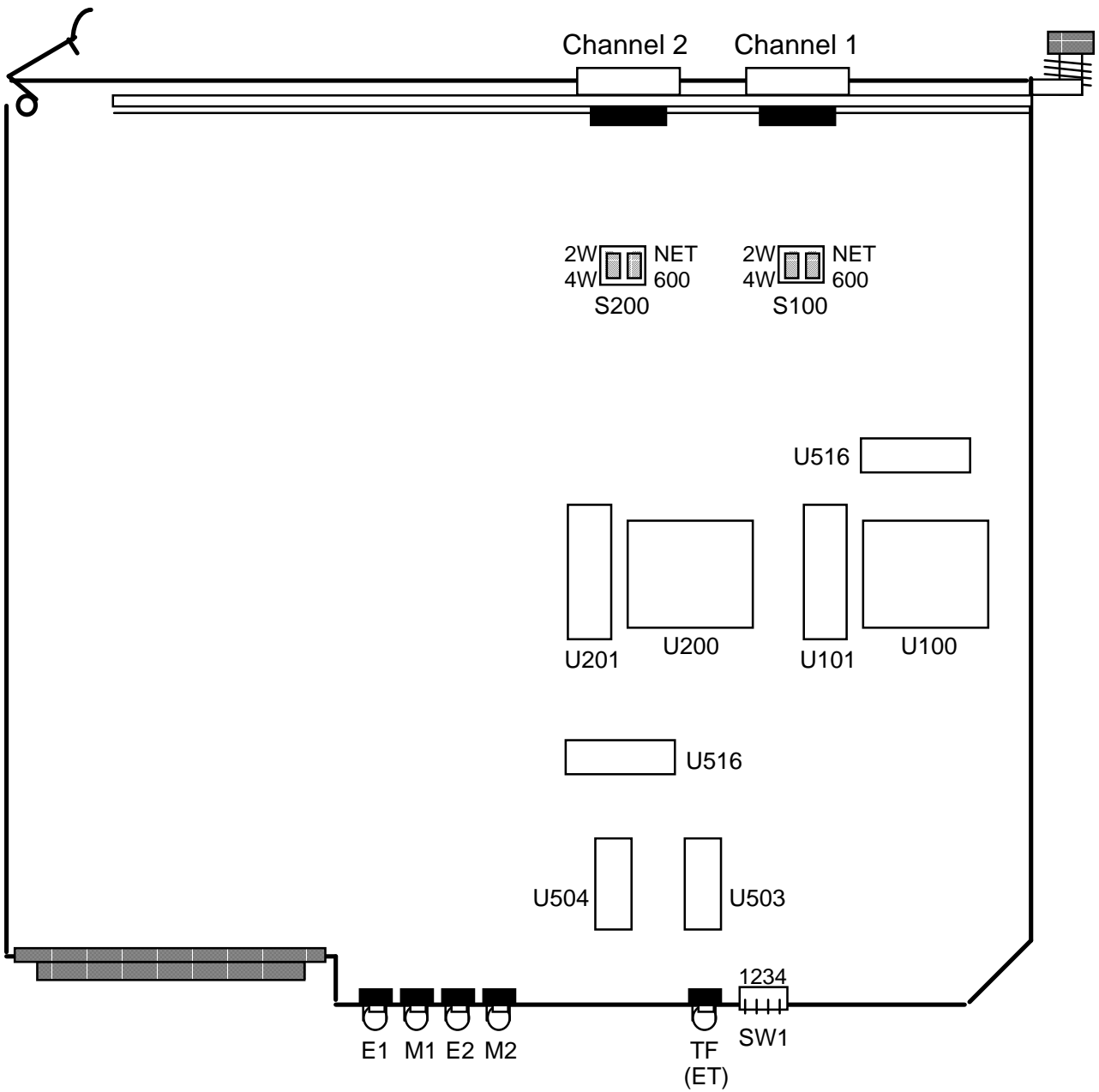

Figure 1-1 TVF & ETVF Switch and F/W positions.

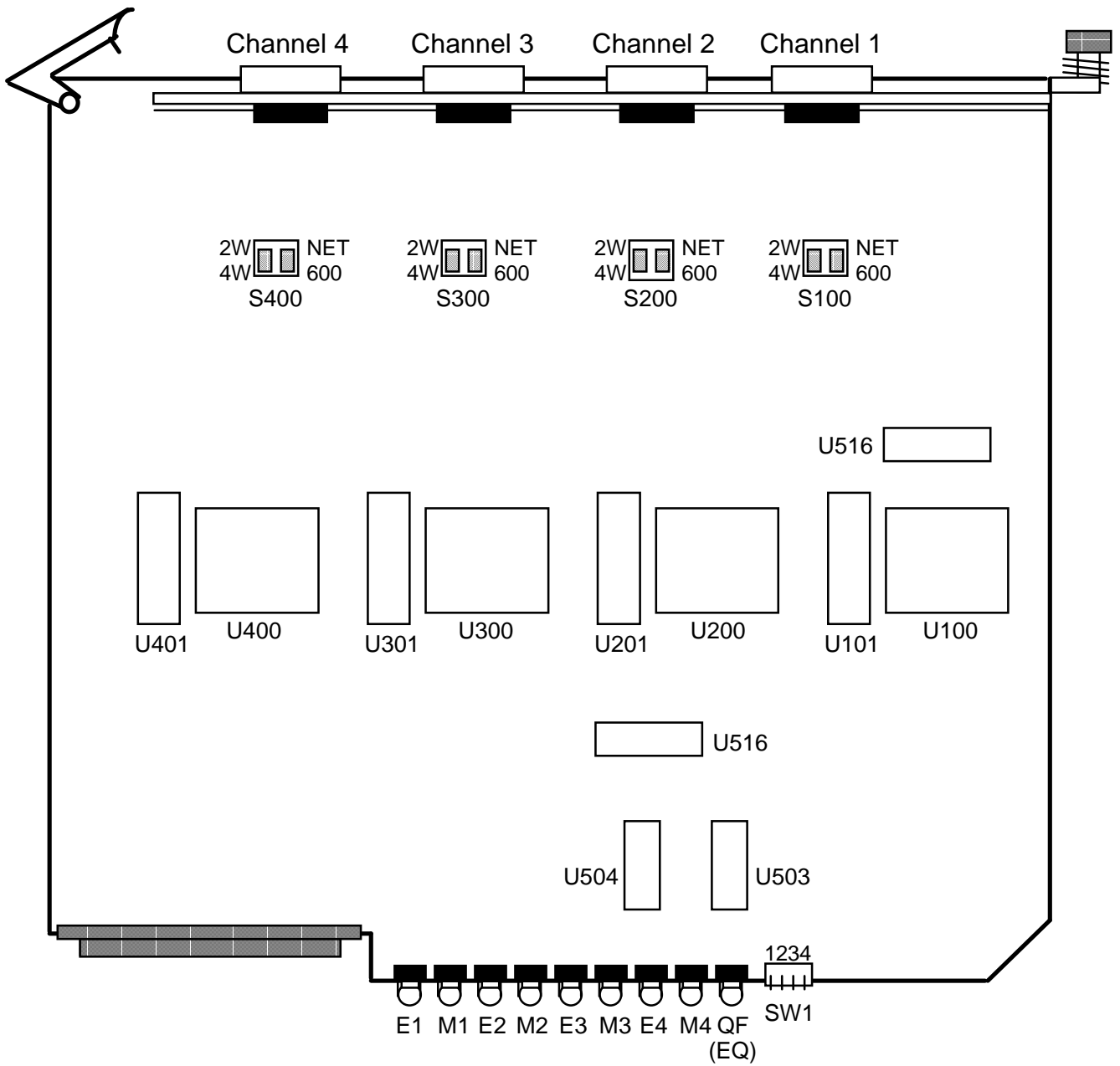

Figure 1-2 QVF & EQVF Switch and F/W positions.

5. Software Configuration

5.1 Adding a New Channel

This facility is not available if the inspect configuration is the active configuration.

Obtain the following display:

```
INSP/MOD CONFIG
PORT m (**)
```

Select the required aggregate port by using the UP and DOWN keys. Press ENTER to display the channels currently configured for the selected configuration 'n'.

```
ADD NEW CHANNEL
FREE B/WIDTH hh %
```

Depressing the ENTER key while this message is displayed allows you to add a new channel to the configuration. You can then scroll through all the available channels by using the UP and DOWN keys until the LBFX channels are shown.

Available channels are those which are physically installed and are not already allocated to the current 'Inspect' configuration for any aggregate port. A midpoint channel is considered available if it is not already programmed for this configuration on the selected port and it is not configured for access by more than one other aggregate port.

The display is the same as that for the configured channels except that the parameters in the second line for data rate and remote channel address are left blank, for example:

```
CH TYPE RATE RCH
A1 LBFX
```

Having selected the required channel address by depressing the ENTER key, the channel parameters are programmed in.

After adding a channel or altering a channels parameters, the channel must be accessed at the remote end of the connection to set up the remote channel parameters, for example, analogue levels etc.

Depressing the ENTER key with the selected channel displayed allows you to modify the various parameters associated with that channel. The parameters can be displayed in turn by repeatedly depressing the ENTER key. When an existing parameter is displayed an alternative may be selected by use of the UP and DOWN keys. The ESCAPE key may be used at any time to exit the channel parameter sub-menu with the currently displayed parameter unaltered. The parameter sub-menu screen displays are described below. In each case 'rr' denotes the local channel address.

5.2 Channel Data Rate

The first display allows the channel data rate to be altered:

```
CH rr RATE: 6.4k      or      CH rr RATE: 0k
                          (DELETE CHANNEL)
```

If the inspect configuration is the active configuration then new channels can not be added. Existing channel parameters can only be viewed. The UP and DOWN keys have no effect on the parameter settings.

The data rate can be altered by using the UP and DOWN keys: the entry below the lowest rate (or above the highest) being 'DELETE CHANNEL' which allows the user to remove the channel from the configuration. If 'DELETE CHANNEL' is selected by pressing the ENTER key, the parameters for the next channel in the configuration will then be displayed.

The ETVF and EQVF may be selected to 9.6k or 6.4k and the TVF and QVF to 6.4k or 4.8k. Fax operation will not work at 4.8k.

5.3 Remote Channel Address

Having determined the data rate the next display facilitates selection of the remote channel address:

```
CH pp REMOTE
ADDRESS qq
```

The current remote channel address is displayed on the second line and the user scrolls through the possible addresses using the UP and DOWN keys to select the required address and then pressing ENTER.

5.4 Channel Maximum Input Level

The overall channel gain for a compressed fax channel on the card can be set up from the front panel. The overall channel gain consists of two basic parameters: maximum expected input level at one end and output gain at the other end.

You can set up the maximum expected input signal level and output gain for each channel independently. Having selected a channel which has been modified or added with configured data rate and remote address, the following parameter set up display is presented:

CHrr MAX INPUT
LEVEL **xxx**dBm

where **xxx** changes by use of the UP and DOWN keys through the four available levels.

5.5 Channel Output Gain

Next you are presented with a screen for configuring the output gain:

CHnn OUTPUT GAIN
yyydB

where **yyy** changes by use of the UP and DOWN keys through the four available gain settings.

It is necessary to set up the input levels and output gains for the remote channel as well as the local one in order to achieve the required end to end channel gains. Having set up the input level and output gain at both ends of a channel, you can calculate the overall end to end gain in either direction by subtracting the configured maximum input level at one end from the output gain at the other. For example, for a channel at multiplexer 'A' with a maximum input level setting of +6dBm communicating with a channel at multiplexer 'B' with an output gain setting of +3dB, the overall end to end channel gain from 'A to B' would be:

$$(+3) - (+6) = -3\text{dB overall}$$

When adding a new channel, the input level and output gains for the remote channel are set to default conditions, i.e. input level of +6dB and output gain of +3dB.

5.6 Pulse Rate

Next, you are presented with a screen for setting the pulse rate:

```
CHrr PULSE RATE
      ssPPS
```

where **ss** changes by use of the UP and DOWN keys through the four possible pulse rates. Currently only 10pps is available. The required pulse rate is selected by pressing the ENTER key.

5.7 Make/Break Ratios

Next, you are presented with a screen for configuring the make/break ratio:

```
CHrr MAKE: BREAK
      tt : xx
```

The UP and DOWN keys will cycle through the four possible make/break ratios. Currently only ratios of 34:66 and 40:60 are available. The required make/break ratio is selected by use of the ENTER key.

The pulse rate and make/break ratio must be set the same for all channels on the card.

Once the last channel parameter is selected and the user depresses the ENTER key, the multiplexer attempts to configure the local and remote multiplexers accordingly. If successful the following message is displayed.

```
CHAN nn CONFIG n
ACCEPTED
```

The configuration may be unsuccessful for a number of reasons and messages are displayed accordingly:

```
CONFIG FAILED
HIGH BANDWIDTH
```

The sum of the channel speeds plus the overhead exceeds the aggregate link data rate:

```
CONFIG FAILED
BAD LINK STATUS
```

The local multiplexer was unable to download data to the remote multiplexer because the status of the aggregate link would not allow for the transfer of supervisor messages:

CONFIG FAILED
NO RESPONSE

The local multiplexer was unable to download data to the remote multiplexer because it received no response to the configuration message even though the aggregate link status is good. This could be due to a momentary burst of errors or sync loss when the message was sent:

CONFIG FAILED
REM MUX N/A

The remote multiplexer is not available because it is currently being accessed by another console; either its own local node or another remote node:

CONFIG FAILED
REM CHAN N/F

The selected remote channel is not available because it does not physically exist:

CONFIG FAILED
REM CHAN TYPE

The selected remote channel type is not compatible with the local channel type:

CONFIG FAILED
REM CHAN RATE

The requested data rate is not available on the remote multiplexer for the selected channel:

CONFIG FAILED
REM CHAN USED

The selected remote channel is not available because it is already configured:

ACTIVE CONFIG
UPDATE INHIBITED

The inspect configuration is the active configuration. Channel parameters are available for viewing only.

Depressing the ESC or ENTER key while the configuration result message is displayed causes the parameters for the selected channel to be displayed again, these will be the new parameters in the case of a successful configuration update, or the old parameters in the case of an unsuccessful one. You can then go on to modify the current or other channels as required.

6. Diagnostics

Selecting DIAGNOSTICS gives access to a number of diagnostic tests and monitoring facilities available on the KMX 9000. Only channel loopback tests are possible on the Compressed Voice/Fax Card.

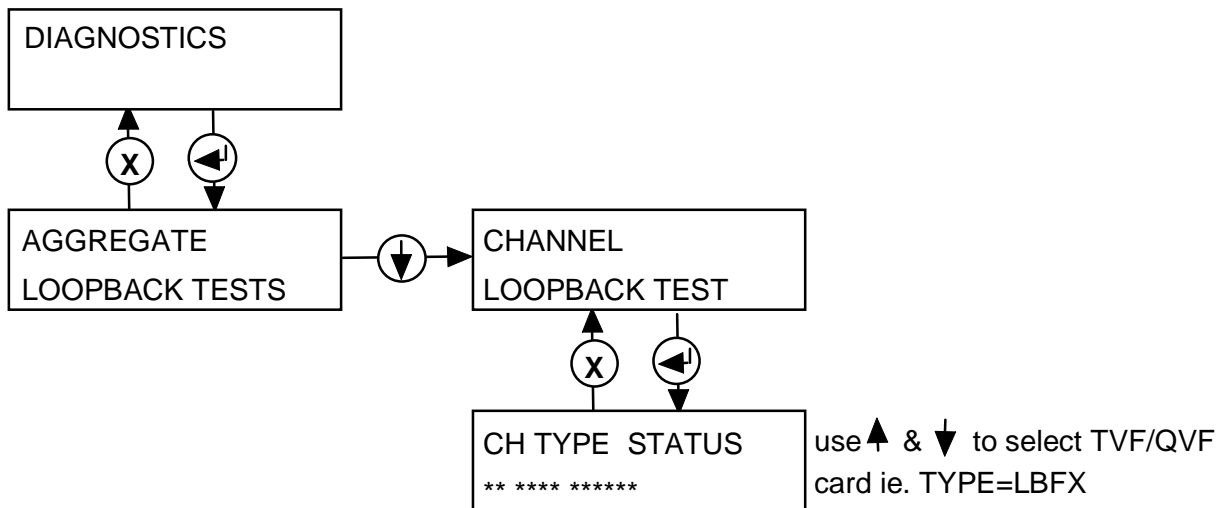

6.1 Channel Loopback Tests

Selecting this option allows you to activate individual channel loopback tests. All available channel types can be put into loop. You can scroll through the status displays for all the physically installed channels using the UP/DOWN keys, for example:

```
CH TYPE STATUS
A1 LBFX LOOP
```

or

```
CH TYPE STATUS
A1 LBFX NORMAL
```

This is a dynamic display which is updated every 2 seconds.

The loopback status can be toggled by depressing the ENTER key when the selected channel is displayed.

The channel loop provided is digital and bi-directional.

Data received from a remotely attached PBX, telephone or internally generated 511 BERT channel is reflected back to the distant source. Similarly, locally received voice is reflected back to the locally attached PBX or telephone. Loopbacks should be used with care as feedback 'howl' is likely to occur in both 2- and 4-wire analogue interfaces.

Echo cancellers are not disengaged when loopbacks are activated, and hence continuous tone testing of a looped circuit will not result in the reflection of clean tones. If AC15 signalling is used and a channel loopback is applied, the 2280Hz output tone will be distorted. E & M signalling is not looped back.

When the LBFX channel is placed into a loopback condition, fax transmission/reception will fail. i.e. it is not possible to utilise the channel loopback to check the integrity of the facsimile transmission.

6.2 Setting a Channel Loopback

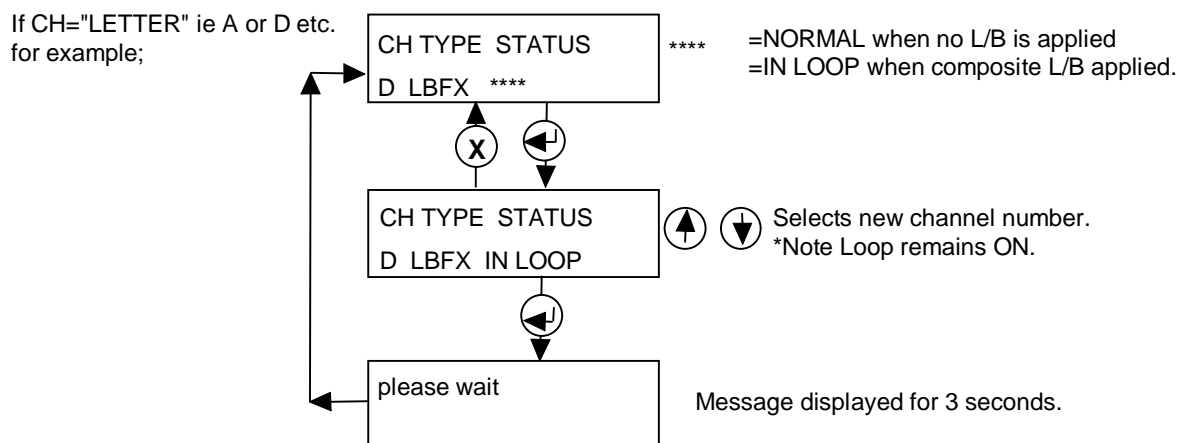

7. Channel Interface I/O Connections

15-way D-Type plug.

Pin No.	Signal Name	Direction
*1	4-wire analogue Input 1	To Mux
*2	4-wire analogue Input 2	To Mux
4	'E' signal (In)	To Mux
5	Telegraph Ground	(must be connected)
7	4-wire analogue Output 1	From Mux
8	4-wire analogue Output 2	From Mux
15	'M' signal (Out)	From Mux

* Input/Output connections for 2-wire working

Unlisted pins are not used or implemented.

8. Interface Connecting Cables

The following interface cables are available from your supplier:

- 1542/005 Cable assembly D15S to Flying leads
For connection of Voice Channel to a Krone block.
Length is 5 metres.

- 1543/001 Cable assembly D15S to D15S
15-way screened cable pin-to-pin to connect the Voice
channel to the QSU (Quad Subscriber Unit)
Length is 1 metre.

Note: When using cable 1542/005 please ensure that the flying earth lead, attached to the cable, is secured to the earth stud located on the rear of the KMX 9000 chassis.

