

# **Quad Exchange Card (QEC) Operation Manual**

Interface Card for the Series KMX 9000 Multiplexers

© Case Communications Ltd 1996

X729-300751 Issue 3

0-1

Rev.2

Unit 15, Riverside Business Centre, Victoria Street, High Wycombe, Bucks HP11 2LT  
Web: [www.casecomms.com](http://www.casecomms.com) Email: [sales@casecomms.com](mailto:sales@casecomms.com)  
Tel (UK): 08700 263 740 Tel (International): +44 (0) 1494 833 740  
Fax (UK): 08700 263 741 Fax (International): +44 (0) 1494 833 741

## STATUTORY NOTICES

### APPROVALS

The BABT approval number for this card is NS/1282/2/P/603728. The 2 wire loop disconnect ports are approved for connection to PABX extension ports or leased lines.

The 2 wire E & M ports are approved for connection to equipment with type SELV (Safe Extra Low Voltage) 2 wire E & M interfaces. Refer to EN6950 for the definition of SELV.

The safety status of the backplane and 2 wire E & M ports is SELV. The safety status of the 2 wire loop disconnect ports is TNV (Telecommunications Network Voltage) as defined in EN41003.



Case Communications Ltd declare that this product conforms with the protection requirements of Council Directive 89/336/EEC on the approximation of the laws of the member states relating to electromagnetic protection.

---

All PCB assemblies contain Electrostatic Sensitive Devices (ESDs) which may be permanently damaged if incorrectly handled. This equipment must be handled in accordance with BS5783 code of practice for the handling of electrostatic sensitive devices .

Case Communications Limited has made all reasonable efforts to ensure the accuracy of the content of this document but the information contained herein does not constitute a warranty of performance of the equipment and/or software described and no specifications given form part of any contract. This document does not constitute a licence to use or copy any software described herein and any such software must only be used in accordance with the terms of the licence supplied herewith.

Case Communications Limited reserves the right to make alterations to the equipment and software described without notice and assumes no liability for any loss or damage caused as a result of use of this document whether because of out of date or inaccurate information or otherwise.

Product and manufacturers' names referred to in this document are used for identification purposes only and Case Communications Limited acknowledges the intellectual property rights of their respective owners in the same.

This document is the copyright of Case Communications Limited and may not be reproduced, copied or stored in any computerised retrieval system by any means without the express written permission of Case Communications Limited.

**Published by Case Communications Technical Publications Department**

# Preface

The QEC is a channel interface card for installation in the Series KMX 9000 range of TDM multiplexers. This manual assumes that the user is familiar with the control of the Series KMX 9000 multiplexers and installation procedures for channel cards. Refer to the Series KMX 9000 multiplexer manual X729-300051 for further details.

## STATUTORY NOTICES continued

If the card(s) are not installed in a Case Communications Series KMX 9000 chassis the following conditions must be met to maintain their approval:

- Ensure that the power drawn by the card(s), together with the chassis and any auxiliary equipment drawing power from the chassis, is within the rating of the chassis power supply. (Refer to the Power Consumption Table in the Series KMX 9000 Multiplexer Reference Manual part number X729-300051.)
- Install the card so that, with the exception of the chassis bus connector, clearance and creepage distances shown in the table below are maintained between the module and all other parts of the chassis which use or generate a voltage shown in the table; the creepage distance shown in brackets applies where the local environment within the chassis is subject to conductive pollution or dry non-conductive pollution which could become conductive due to condensation.

| Clearance (mm) | Creepage (mm) | Voltage used or generated by host or other cards |
|----------------|---------------|--|
| 2.0            | 2.4 (3.8)     | Up to 50 Vrms or Vdc                             |
| 2.6            | 3.0 (4.8)     | Up to 125 Vrms or Vdc                            |
| 4.0            | 5.0 (8.0)     | Up to 250 Vrms or Vdc                            |
| 4.0            | 6.4 (10.0)    | Up to 300 Vrms or Vdc                            |

- For a chassis using or generating voltages greater than 300 V (rms or dc), you must obtain advice from a competent telecommunications safety engineer before installing the modules.

# Contents

---

|          |   |     |
|----------|---|-----|
| <b>1</b> | <b>Introduction</b>                     | 1-1 |
| 1.1      | General                                 | 1-1 |
| 1.1.1    | Mechanical                              | 1-1 |
| 1.1.2    | Signalling                              | 1-1 |
| <b>2</b> | <b>Voice Circuits</b>                   | 1-3 |
| 2.1      | Voice Circuits                          | 1-3 |
| 2.1.1    | 2-Wire Loop Disconnect port             | 1-3 |
| 2.1.2    | 2-Wire E & M ports                      | 1-3 |
| <b>3</b> | <b>Hardware Configuration</b>           | 1-3 |
| 3.1      | Link Options                            | 1-3 |
| <b>4</b> | <b>Interface Connections and Cables</b> | 1-5 |

## Figures

|     |                                     |     |
|-----|-------------------------------------|-----|
| 1-1 | Typical application using DVC Cards | 1-2 |
| 1-2 | QEC Board Layout                    | 1-5 |



# Quad Exchange Card

---

## 1. Introduction

### 1.1. General

This card fits into any Series KMX 9000 chassis from which it derives its power. All other connections are made using external cables. Refer to the Series KMX 9000 manual for installation details for interface cards.

Two signalling converters are required to allow a local office PABX extension to be connected to a remote subscriber telephone via a multiplexer link employing voice compression techniques and E&M signalling interfaces.

At the PABX end, the Quad Exchange Card (QEC) provides four interfaces to PABX Loop Disconnect 2-wire extension lines with conversion to 2-wire E & M interfaces. This allows for connection to Compressed Voice Cards (QCV/TCV and variants), or Data and Voice Cards (DVC), to provide low bit rate voice transmission with signalling to a remote telephone.

At the remote end a subscriber interface converter will be required and this can be provided by a Quad Subscriber Unit (QSU) or a Voice Adaptor, both of which are described in their relevant manuals and are available from your supplier.

#### 1.1.1 Mechanical

The card is a single plug-in card for the Series KMX 9000 multiplexers.

#### 1.1.2 Signalling

The card emulates a telephone with operation as follows: Ringing voltage will be detected by the QEC from the two wire PABX output causing the 'M' signalling output of the card to toggle in time with the cadenced ringing. The convention used is that of ringing voltage present, 'M' lead busy (earthed).

As an option the cadence in the outgoing signalling may be disabled, this allows for the case where the remote subscriber interface generates its own ringing cadence as in the Case Communications products.

In the reverse direction, the QEC 2-wire card output to the PABX will toggle between open circuit and the looped condition in time with the 'E' signalling input. The signalling convention used is 'E' lead busy, 2-wire line looped.

Ground start is also supported as a link option. Following the input 'E' lead changing to the busy condition the card will connect earth to the 'B' wire at the loop disconnect interface. When the exchange responds with 'A' wire earth, the earth on the 'B' wire is removed and the call progresses as for loop start.

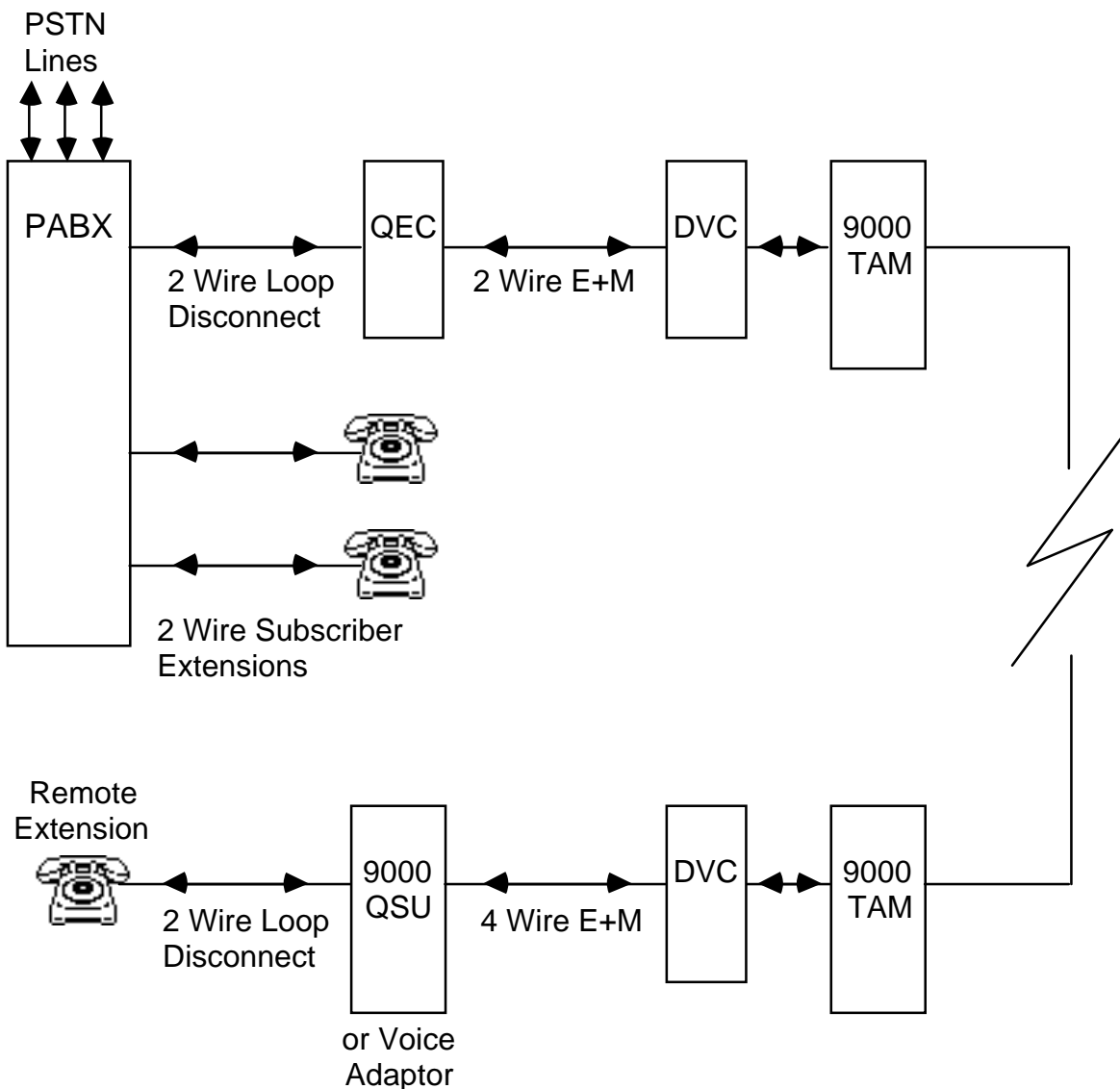

**Figure 1-1 Typical Application using DVC Cards**

## 2. Voice Circuits

### 2.1 Circuit Description

#### 2.1.1 2-Wire Loop Disconnect port

The 2-wire exchange voice circuit is transparently connected to the compressed voice circuit associated with the E&M interface. There is no line termination provided on the QEC, - this is set by the QCV/TCV/DVC and variants.

The connections for the 2-wire exchange circuits are presented on RJ45 sockets.

#### 2.1.2 2-Wire E & M ports

The voice circuits associated with the E&M circuits are 2-wire for connection to the QCV/TCV/DVC.

The interface is presented on 15-way D-type connectors arranged to allow connection to a compressed voice card fitted in another slot via an external ribbon cable assembly. It is not necessary for the QEC and the voice cards to be adjacent or be in the same chassis.

**2.1.3 MTBF:** The MTBF calculated to HRD4 is 35 years.

#### 2.1.4 Power Consumption

|        |      |      |     |
|--------|------|------|-----|
| +5V    | +12V | -12V | -5V |
| 1000mA | 40mA | 40mA | 1mA |

#### 2.1.5 Environmental

|                       |                         |
|-----------------------|-------------------------|
| Operating Temperature | +5°C to +40°C           |
| Storage Temperature   | -25°C to +55°C          |
| Humidity              | 5 to 95% non-condensing |

## 3. Hardware Configuration

### 3.1 Link Options

Two options provided by the QEC may be selected using card mounted links:

Loop or Ground start  
Outgoing ringing type

The options may be set on a per channel basis using links as follows:

JP1 Channel 1  
JP2 Channel 2  
JP3 Channel 3  
JP4 Channel 4

These links select either loop or ground start and are marked 'Earth' or 'Loop' on the PCB.

Position 1-2 Loop Start  
Position 2-3 Ground Start

JP5 Channel 1  
JP6 Channel 2  
JP7 Channel 3  
JP8 Channel 4

These links select cadenced or continuous ringing for the outgoing 'M' lead signalling and are marked '—' for continuous ringing or '----' for cadenced ringing on the PCB.

Position 1-2 Cadenced ringing  
Position 2-3 Continuous ringing

Soldered links are provided to individually change the state of the 'E' and 'M' signalling leads at the two wire E&M interface.

LK1 (M) and LK2 (E) Channel 1  
LK3 (M) and LK4 (E) Channel 2  
LK5 (M) and LK6 (E) Channel 3  
LK7 (M) and LK8 (E) Channel 4

The card is supplied with the links short circuit which provides the standard input and output conditions of 'idle' open circuit and 'busy' earthed. Breaking the link for either the 'E' or the 'M' lead will reverse this condition giving 'idle' earthed and 'busy' open circuit.

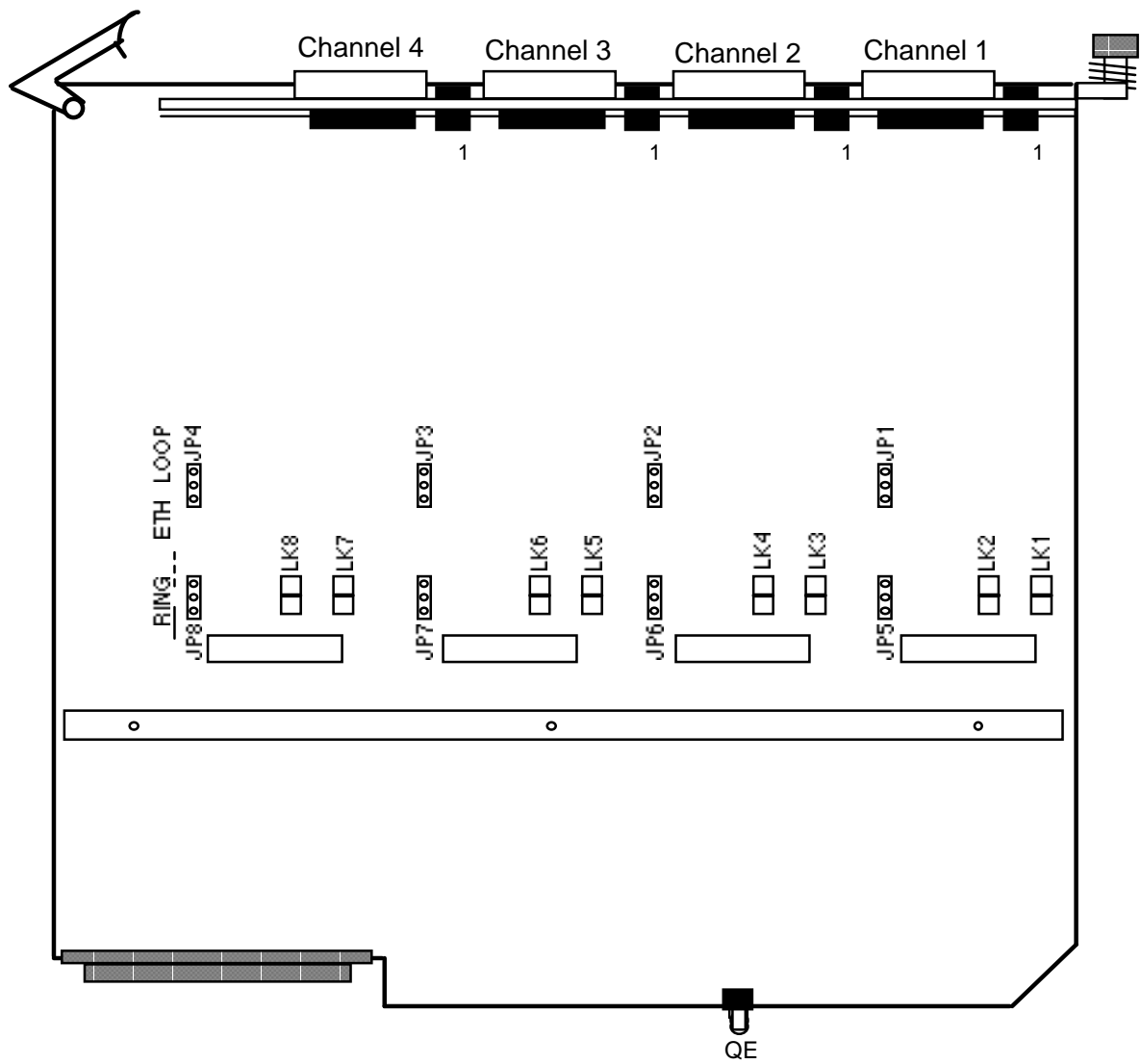

**Figure 1-2 QEC Board Layout**

## 4. Interface Connections and Cables

The connections to the 15-way D-type connectors are as follows:

|             |                            |
|-------------|----------------------------|
| Pin 1 and 2 | 2-wire Input/Output        |
| Pin 15      | Signalling input 'E' lead  |
| Pin 4       | Signalling output 'M' lead |
| Pin 5       | Signalling ground          |

The connections to the RJ45 connectors are as follows:

|       |          |
|-------|----------|
| Pin 5 | 'A' wire |
| Pin 4 | 'B' wire |

Pin 1 of the RJ45 connector is as shown on figure 1-2.

### Cables

The following cable assemblies are available from your supplier:

|          |  |
|----------|--|
| 1542-XXX | Cable Assembly D15S to flying lead<br>Used to connect the QEC to a Krone block MDF rack<br>E&M side.                         |
| 1546-001 | Cable Assembly D15S to D15S<br>15 way ribbon cable, pin to pin, to connect a voice<br>circuit to the QEC. Length is 1 metre. |
| 1549-XXX | Cable Assembly RJ45-BS6312 Telephone Jack Plug<br>Used to connect the QEC to a BT Wall socket.                               |
| 1550-XXX | Cable Assembly RJ45 to flying lead<br>Used to connect the QEC to a Krone block MDF rack<br>LD side.                          |

XXX denotes the cable length in metres: to be specified on order. The standard cable length of 2 metres will be supplied (i.e. 002) if the length is not specified.