

**Integrated Services Module  
Operation Manual**  
Module for the Series KMX 9000

© Case Communications Ltd 1997

X729-300951 Issue 5

0-1

Rev.0

Unit 15, Riverside Business Centre, Victoria Street, High Wycombe, Bucks HP11 2LT  
Web: [www.casecomms.com](http://www.casecomms.com) Email: [sales@casecomms.com](mailto:sales@casecomms.com)  
Tel (UK): 08700 263 740 Tel (International): +44 (0) 1494 833 740  
Fax (UK): 08700 263 741 Fax (International): +44 (0) 1494 833 741

## STATUTORY NOTICES

### APPROVALS

The BABT approval number for this apparatus is NS/1282/5/P/604137.

The ISM is approved for connection to Basic Rate ISDN interfaces.

The backplane connector is SELV. The ISDN port is TNV.



Case Communications Ltd declare that this product conforms with the protection requirements of Council Directive 89/336/EEC on the approximation of the laws of the member states relating to electromagnetic protection.

---

All PCB assemblies contain Electrostatic Sensitive Devices (ESDs) which may be permanently damaged if incorrectly handled. This equipment must be handled in accordance with BS5783 code of practice for the handling of electrostatic sensitive devices.

Case Communications Limited has made all reasonable efforts to ensure the accuracy of the content of this document but the information contained herein does not constitute a warranty of performance of the equipment and/or software described and no specifications given form part of any contract. This document does not constitute a licence to use or copy any software described herein and any such software must only be used in accordance with the terms of the licence supplied herewith.

Case Communications Limited reserves the right to make alterations to the equipment and software described without notice and assumes no liability for any loss or damage caused as a result of use of this document whether because of out of date or inaccurate information or otherwise.

Product and manufacturers' names referred to in this document are used for identification purposes only and Case Communications Limited acknowledges the intellectual property rights of their respective owners in the same.

This document is the copyright of Case Communications Limited and may not be reproduced, copied or stored in any computerised retrieval system by any means without the express written permission of Case Communications Limited.

**Published by Case Communications Technical Publications Department**

# Contents

---

<b>1</b>	<b>General Description</b>	1-1
<b>2</b>	<b>ISDN Basic Rate Interface (BRI) Requirements</b>	1-1
<b>3</b>	<b>Specifications</b>	1-2
<b>4</b>	<b>Network Planning Considerations</b>	1-3
<b>5</b>	<b>Security</b>	1-4
<b>6</b>	<b>LED Indicators</b>	1-5
<b>7</b>	<b>Links</b>	1-5
7.1	Main Board Links	1-5
7.2	BRI Module Links and EPROMS	1-6
<b>8</b>	<b>Configuring the ISM</b>	1-8
8.1	ISM Line Parameters	1-8
8.2	ISDN Numbers Menu	1-9
8.3	ISDN Line Configuration Menu	1-10
8.4	ISDN Dialling Timetable Menu	1-11
8.5	ISDN Password & Extended Sub-address Menu	1-12
8.6	Close ISDN Call	1-13
<b>9</b>	<b>Diagnostics</b>	1-13
9.1	ISM Diagnostics Menus	1-13
9.2	ISM Engineering Diagnostics Menu	1-15

## Figures

1-1	ISM Board Layout	1-7
1-2	BRI Board Layout	1-7



# Integrated Services Module

---

## 1. General Description

The ISM is an interface module for installation in the Series KMX 9000 range of TDM multiplexers. This manual assumes that you are familiar with the control of the KMX 9000 multiplexers and installation procedures for channel cards. This manual applies to modules fitted in Series KMX 9000 multiplexers with TLM/QLM firmware Version 3.10 or later. Refer to the Series KMX 9000 multiplexer manual for further details.

The 9268 Integrated Services Module (ISM) provides a back-up facility over the Integrated Services Digital Network (ISDN) in the event of trunk line failures between nodes of a KMX 9000 network. The back-up uses the ISDN Basic Rate service via the local Basic Rate Interface (BRI).

In the event of a trunk failure between two KMX 9000 nodes, an ISDN connection will be established automatically between the two nodes and this connection will be used in place of the failed trunk. This service is only available to back-up 64k trunks. A single BRI with two B channels is used to back up the two trunk lines on a TLM or any two of the four trunk lines on a QLM on a first come first served basis.

The configuration data for the ISM is held in the battery-backed RAM on the TLM/QLM, therefore the ISM may be exchanged without the necessity for re-programming.

This manual refers to ISM modules fitted with Version 1.xx firmware. Future upgrades will be carried out using a software download facility which is a feature of the Series KMX 9000 multiplexers. Full details for using this facility can be found in the DomainView Series KMX 9000 MM manual.

## 2. ISDN Basic Rate Interface (BRI) Requirements

Single and dual number lines are supported but single number lines are preferable since they permit much quicker and more efficient call establishment when multiple trunk failures occur on one node. Single number lines may be less expensive to operate since some providers

charge for subscription options on a 'per number' basis. Calling Line Identification (CLI) may be configured for use by the ISM.

Should CLI be configured on the ISM, it is essential that it is subscribed to on the BRI. In the case of two number lines, CLI must be subscribed to on both numbers.

The sub-address option of the BRI must be subscribed to because the ISM uses this as a security feature and to uniquely identify incoming calls. In the case of two number lines, sub-addressing must be subscribed to on both lines.

Multiple Subscriber Numbering (MSN) is not used by the ISM.

Connection from the card to the BRI is via the lead fitted to the unit. This terminates with an RJ45 plug for connection to the wall socket (NT1). This cable must not be altered or replaced. Should other vendors' equipment be connected to the same BRI as the ISM, it is essential that the associated interface cabling does not introduce a polarity reversal. It is recommended that only approved cables, conforming to ISO 8877 are used.

### **3. Specifications**

#### **Transmission Characteristics**

The card transfers data transparently between interfaces and services.

#### **Delay**

The delay from the multiplexer backplane to the ISDN interface is 660µs.

The delay from the ISDN interface to the backplane is 660µs.

#### **Gain**

When the ISM is used to provide a data path for pre-multiplexed voice traffic, the relative level for both the transmit and receive transmission paths is fixed at 0dB.

#### **Quantisation Distortion**

When the ISM is used to provide a data path for pre-multiplexed voice traffic, the quantisation distortion contributed by the card for both transmit and receive directions is zero.

## **Power Consumption**

The maximum power consumption on each voltage rail, excluding any initial surge, is as follows:

+5V:	4.25W	800mA
+12V:	0.25W	20mA
-12V:	0.25W	20mA

## **Environmental**

Operating temperature: 0 to +45<sup>0</sup>C

Storage Temperature: 0 to +70<sup>0</sup>C

Operating humidity: to 95% R.H. non-condensing at +40<sup>0</sup>C

Storage humidity: to 95% R.H. non-condensing at +55<sup>0</sup>C

## **MTBF**

The MTBF figure calculated to HRD4 is 11.5 years.

## **4. Network Planning Considerations**

When planning a network for ISDN backup, it is advisable to consult the service provider to ensure that resilience in the service is available and consideration should at least be given to the following points:

- a) The ISDN line and the leased line should be provided in separate cables.
- b) The ISDN and leased line cables should be in separate ducts.
- c) The ISDN and leased line service should be provided from different exchanges.
- d) The ISDN and leased line service should enter your premises at different points.
- e) Does the service provider have diversity routing for the ISDN service?

It is important that the ISDN line is checked as a matter of routine to ensure that the service is functional, particularly if it is not being used for another purpose and may be idle for long periods of time. This may be achieved by means of the ISM's 'ISDN DIAGNOSTICS' menu.

## **5. Security**

- a) Each trunk may be configured in the directory to be either the initiator of the ISDN back-up (outgoing calls only) or the respondent to an ISDN back-up attempt (incoming calls only). This feature can be used to inhibit incoming calls from potentially insecure nodes.
- b) ISDN data transferral access is inhibited while the trunk lines are operational. When a trunk goes down, ISDN access will be enabled only for calls corresponding to the failed trunk.
- c) The ISM utilises the sub-address facility available on the BRI. Each trunk in the network has a unique sub-address allocated to it which consists of two characters determined automatically by the ISM from the network topology, and up to two characters that are user configurable as the extended sub-address (ESA) parameter. The responding ISM will only accept calls to sub-addresses that it has identified as the sub-address of a trunk that has failed.
- d) Rate adaptation as defined in V.110 and X.30 is not supported by the ISM.
- e) The protocol running on the trunks being backed-up is a Case proprietary protocol that would be unintelligible to other vendors' equipment and has a further security feature that verifies the connection is being made to the correct node and trunk.
- f) The ISM may be configured to use a password and key exchange procedure for authentication of the remote ISM. This exchange is encrypted using a polynomial algorithm.
- g) The ISM may be configured to utilise CLI (Calling Line Identification) validation. If this feature is to be used, CLI must be subscribed to on the ISDN BRI. If configured for CLI validation, the ISM will only permit incoming calls that have a CLI in the call set-up parameters that corresponds to a CLI defined in its directory. CLIs are only stored in this directory for ports that are defined as incoming and have CLI validation enabled. The CLI entries are ISDN number defined on the remote ISMs to these ports. The numbers are passed across the aggregate link, when the link is established, or when the numbers are changed.

## **6. LED Indicators**

The ISM board has 9 LED indicators as follows:

One 'Green' labelled 'IS'. This LED is permanently 'ON' to indicate that the board has passed its self check and flashes during self check and if the self check has failed. The self check period lasts for about 45 seconds.

Eight 'Red' labelled in pairs 'T0', 'T1', 'T2', 'T3'. Pairs of red LEDs are assigned to the trunks. When a trunk is being backed up, the left LED of the pair associated with that trunk will flash during call establishment. Both LEDs will flash once the call has been successfully established and for the duration of the call. The LEDs will light permanently for a given trunk if a password/key verification error occurs. This will only be cleared once a successful ISDN call has taken place.

## **7. Links**

### **7.1 Main board links**

There are two links on the main board which should always be set as follows:

JP1: Should be set to position 1-2 (NORMAL). 2-3 (TEST) mode is not used on this issue of the ISM.

JP3: Should be set to position 1-2 (EN). 2-3 (DIS) mode is for production test purposes only.

## 7.2 BRI Module Links and EPROMs

Links on the BRI module are not easily accessible and will require removal of the board to gain access to them. They should *not* be changed from the positions shown in Figure 1-2 and have the following functions:

		Posn. A	Posn. B	Setting
LK1	DTE port 2 LMT selection	Enabled	Disabled	A
LK2	DTE port 2 LL selection	Enabled	Disabled	A
LK3	DTE port 1 LL selection	Enabled	Disabled	A
LK4	DTE port 1 LMT selection	Enabled	Disabled	A
LK5	Diagnostics selection	Diagnostics mode	Normal Mode	A
LK6	Watchdog interrupt	Disabled	Enabled	A
LK50	COM - TxD source	COM port	DTE 1 Sec TxD	B
LK51	DTE 1 Sec RxD	SCC 1	SCC 2	B

### Glossary:

BRI	Basic Rate Interface (ISDN)
COM	COMmand port
DTE	Data Terminal Equipment (port)
ISDN	Integrated Services Digital Network
LL	Local Loopback. V.24 circuit 141
LMT	Loopback Maintenance Test. V.24 circuit 140
RxD	Received Data
SCC	Serial Communications Controller
Sec	Secondary
TxD	Transmitted Data

### Minimum Software levels required:

U35	01/02/C checksum 6526
U36	01/02/C checksum 5A91

However some boards may be fitted with 01/02/cc which is functionally identical.

U35	01/02/cc checksum C46A
U36	01/02/cc checksum 39AE

The software level of the BRI module may be determined from the front panel by accessing the Software Version Numbers menu in the Diagnostics menu. The BRI module is displayed as ISDN.

The part number for the BRI module is X450-604612 with a minimum build level of issue 1.

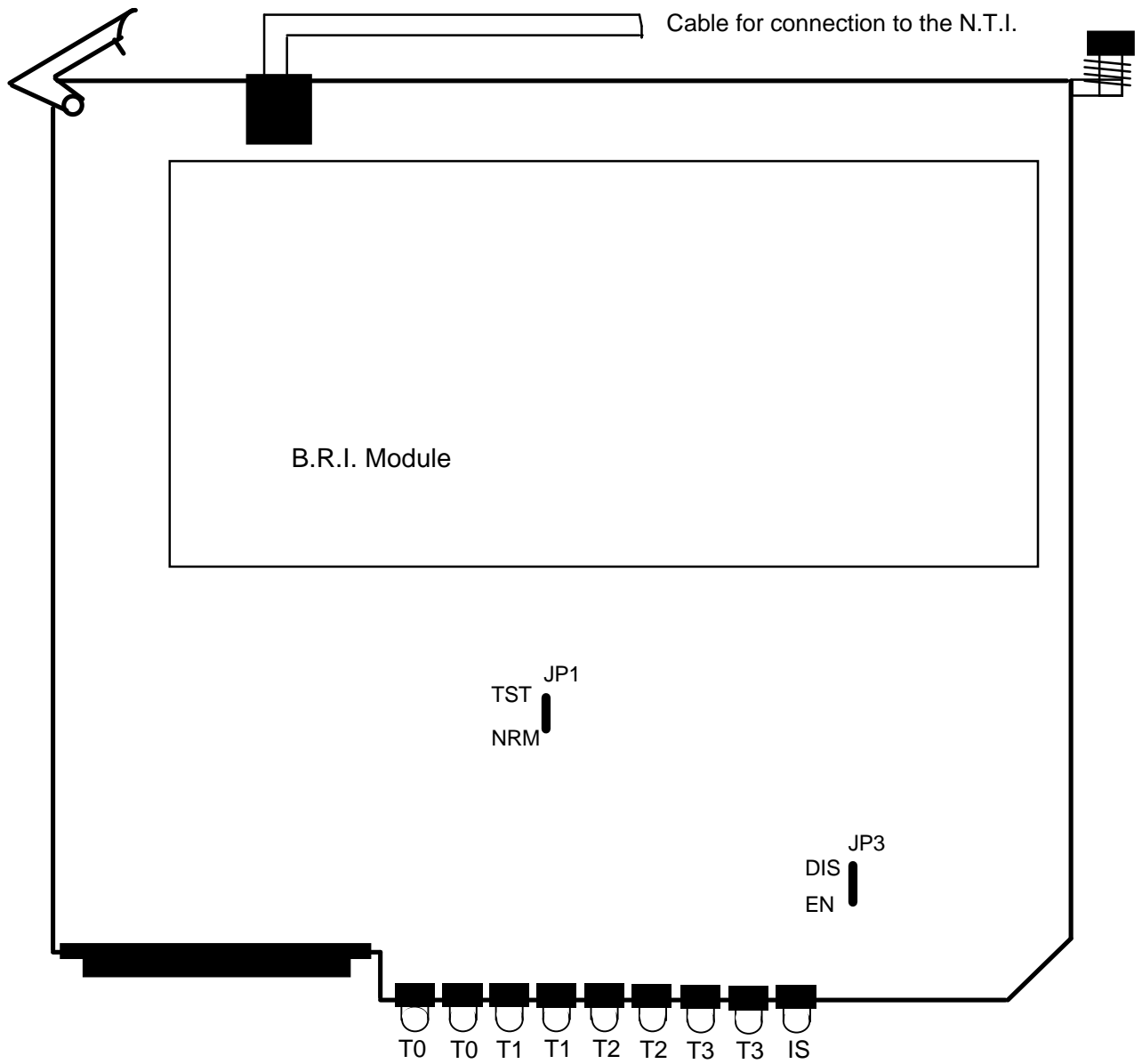

**Figure 1-1 ISM Board Layout**

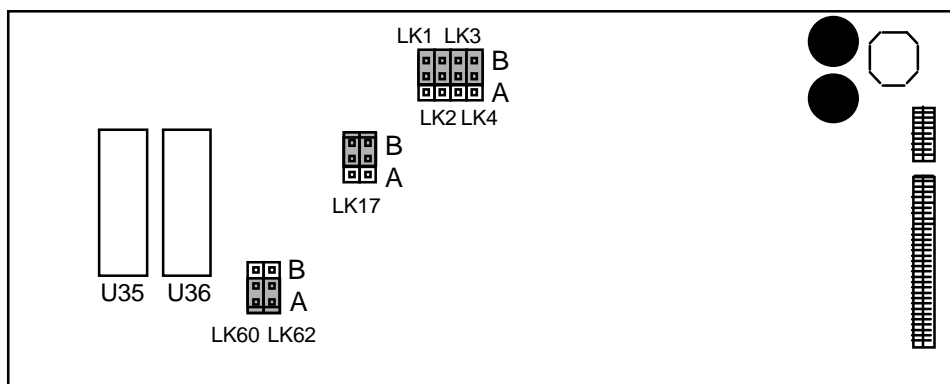

**Figure 1-2 BRI Board Layout**

## **8. Configuring the ISM**

The ISM can be configured using the front panel facilities provided by the TLM/QLM or by using the network management platform.

The configuration instructions given in this manual apply to operation using the front panel. Configuration using the network management platform 'DomainView', is covered in a separate manual for the product.

The menu structure for the ISM is described in this chapter. Brief descriptions of each function in the menu are given. Functions not described are not used on this issue of the ISM product.

Note that although the ISMs local database is updated as soon as each menu is completed, the database in the Aggregate Link Module battery backed RAM and the ISM directory, are only updated when control returns to the 'MODIFY LOCAL PARAMETERS' menu. It is only at this time that the configuration information, such as the ISDN numbers, is conveyed across the aggregate link to the remote ISMs.

### **8.1 ISM Line parameters**

Configuration of the ISM line parameters is accessed through the KMX-9000 top level 'MODIFY LOCAL PARAMETERS' menu.

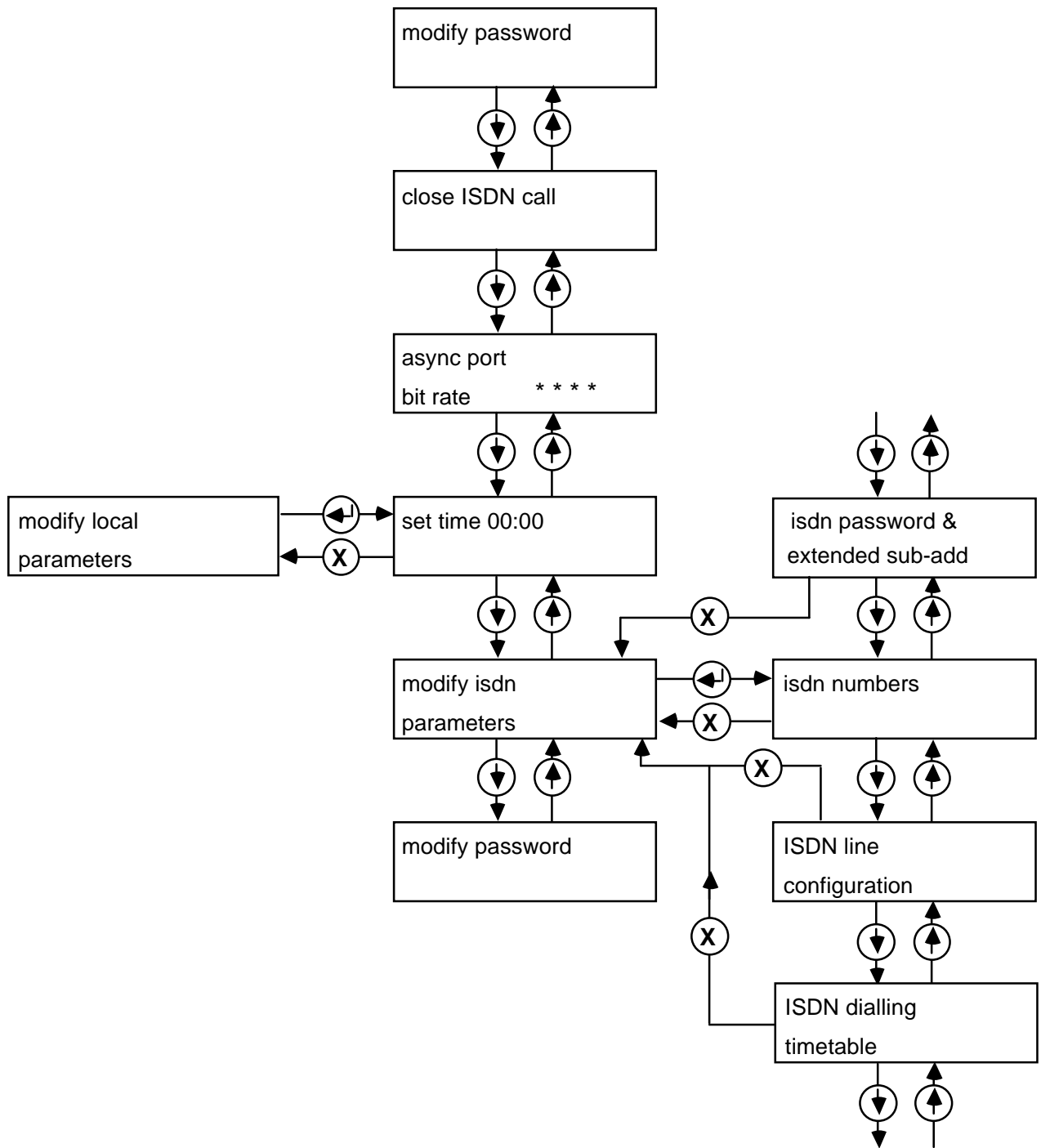

## 8.2 ISDN Numbers Menu

The local ISDN number should be entered as follows: Note that the remote ISDN numbers are *not* entered at the local multiplexer; the local multiplexer obtains this information through the inter-multiplexer supervisor channel.

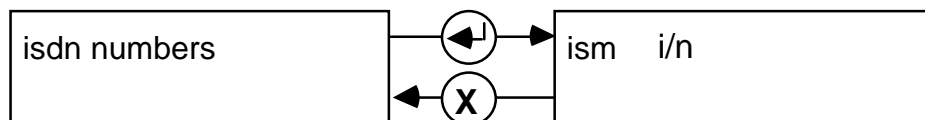

i	1/2	ISM number. Up/down arrows toggle, <CR> moves to 'n' field. (only 1 ISM may be configured so this field may not be changed)
n	1/2	dial number index. Up/down arrows toggle 1/1 or 1/2, <CR> moves to the second line where the dial number is entered. Each of the first 15 positions on the second line may be set to a digit in the range 0-9 or a space by means of the up/down arrow keys. The first space terminates the dial number, a space in the first location deletes the number.

For single number lines, 1/2 should be cleared. 1/2 cannot be configured unless 1/1 has already been configured. If 1/1 is deleted 1/2 becomes 1/1.

### 8.3 ISDN Line Configuration Menu

The line configuration of the ISDN circuit associated with each trunk, is entered through the following menus. Each circuit should be configured as 'incoming', 'outgoing' or 'disabled'. Dialling ends should be set for 'outgoing' and the receiving end should be configured for 'incoming'. In the U.K., calls are charged to the dialling party. The calling line identification 'CLI' facility, is a security feature which should only be set if the CLI feature is subscribed to. Contact your ISDN supplier for details. Non 64k trunks should be configured as disabled since they cannot be backed up by the ISM, as should any trunk for which ISDN backup is not required.

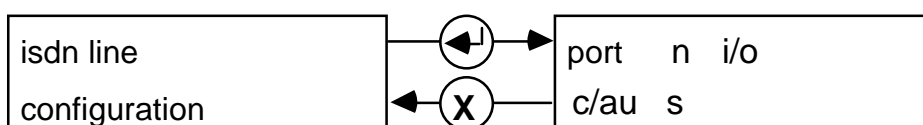

n	0/1(2/3)	up/down arrow loops round possible values, 2 and 3 are only accessible if a QLM is fitted. <CR> moves to i/o field.
i/o	I/C, O/G or DIS	up/down arrows toggle <CR> moves to the 's' field.  I/C = incoming O/G = outgoing DIS = back-up disabled for this port
c/au	CLI	field toggles with incoming/outgoing selection. Only available for incoming lines.

s Y/N CLI configured or not. Up/down arrows toggle Y/N, on <CR> entry is accepted.

## 8.4 ISDN Dialling Timetable Menu

The ISM can be configured to avoid using the ISDN line during a defined period of the day. The purpose of this facility is to save call charges by preventing backup over the ISDN during periods when data loss would be acceptable to the user.

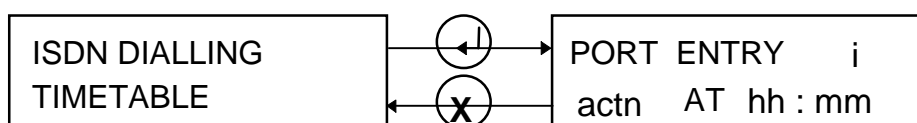

- |      |                       |  |
|------|-----------------------|--|
| n    | 0/1/2/3               | up/down arrows loop round the values, <CR> moves to 'i' field  |
| i    | 0/1/2/3               | index into timetable. Up/down arrows loop round the values, <CR> moves to 'actn' field.  |
| actn | NULL/ENAB/<br>DIS/CLR | up/down arrows cycle, <CR> selects ENABLE or DISABLE and moves to 'hh' field or CLEARS the entry and goes back to the parent menu.<br>NULL indicates that this entry has not yet been created. NULL in entry 0 indicates that there is no timetable for this port, this implies that back-ups are not disabled by timetable at any time. |
| hh   | 00-23                 | hours, up/down arrows increase or decrease each digit. <CR> on first digit moves to second digit. <CR> on second digit moves to 'mm' field.  |
| mm   | 00-59                 | minutes, up/down arrows increase or decrease each digit. <CR> on first digit moves to second digit. <CR> on second digit accepts the entry. Entries are re-ordered chronologically at this point.  |

If there is no entry in the timetable for a port then backup is enabled at all times. This may be overridden by a DIS entry in the ISDN Line Configuration menu.

Changes to the timetable only become effective upon returning to the 'Modify Local Parameters' menu.

## 8.5 ISDN Password & Sub-address Menu

This menu is provided for two purposes:

a) Where the security provided by the ISM password exchange feature is not required it may be disabled. If password exchange is enabled, the unit will refuse to communicate with any node in which password exchange has been disabled. It is recommended that password exchange is universally enabled or disabled.

b) The default sub-addressing used by the ISM to ensure validity of the ISDN connection is based on the premise that node numbers are unique within a network. Users with large networks that are divided into several sub-networks, will have multiple nodes with the same number. The Extended Sub-address feature is provided to ensure the uniqueness of each sub-address within complex networks of this nature. Each node in the network with the same node number should be configured to have a different extended sub address (ESA).

In simple networks it is recommended that the extended sub-addressing field is set to <null> i.e. not used. This feature is only necessary within complex networks constructed from multiple zones employing duplicated multiplexer node numbers. Note that the BRI's sub-address facility must be subscribed to whether or not the sub-address extension is employed.

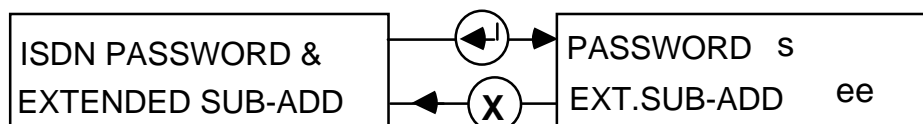

s            Y/N            Select use of password key exchange Yes or No

ee            The sub-address extension field.

e = 0-9,A-Z, <null>

a <null> in the first character clears the second character to <null> and implies that the sub-address extension is disabled.

## 8.6 Close ISDN Call

There are a number of mechanisms for ISDN call closure:

- a) Manual call closure as described in this section.
- b) Multiplexer failure at either end of the link.
- c) ISDN Network failure.
- d) Automatic call closure due to the ISM's call inhibition timetable. Sec 8.4.
- e) Automatic call closure, requested by the trunk module, in order to restore connection across a repaired 64k leased aggregate circuit. Auto restoration from ISDN to a repaired leased circuit is controlled solely by the trunk module. The trunk module will restore to a repaired aggregate, after monitoring ten minutes of error-free data. This feature is only available in trunk software version 3.1 or later.

To manually close an ISDN call, select 'CLOSE ISDN CALL' from the 'MODIFY LOCAL PARAMETERS' menu.

Within the 'CLOSE ISDN CALL' sub-menu the up-down keys select the trunk, whereupon the status OPEN or CLOSED is displayed. <CR> on an open call closes the call on the individual trunk selected. <ESC> returns to the parent menu.

## 9. Diagnostics

### 9.1 ISM Diagnostics Menus.

The ISM provides a simple diagnostics facility which can be used to confirm the operation of the ISDN connection between multiplexers. In order to initiate a diagnostics call, *both* ends of the link should be configured: one to dial and one to answer.

Diagnostic calls do *not* interrupt the data being transferred across the trunk module aggregate links, or across the ISDN.

Diagnostic calls can be attempted at any time, however calls will not be successfully established if both ISDN 'B' channels are already in use.

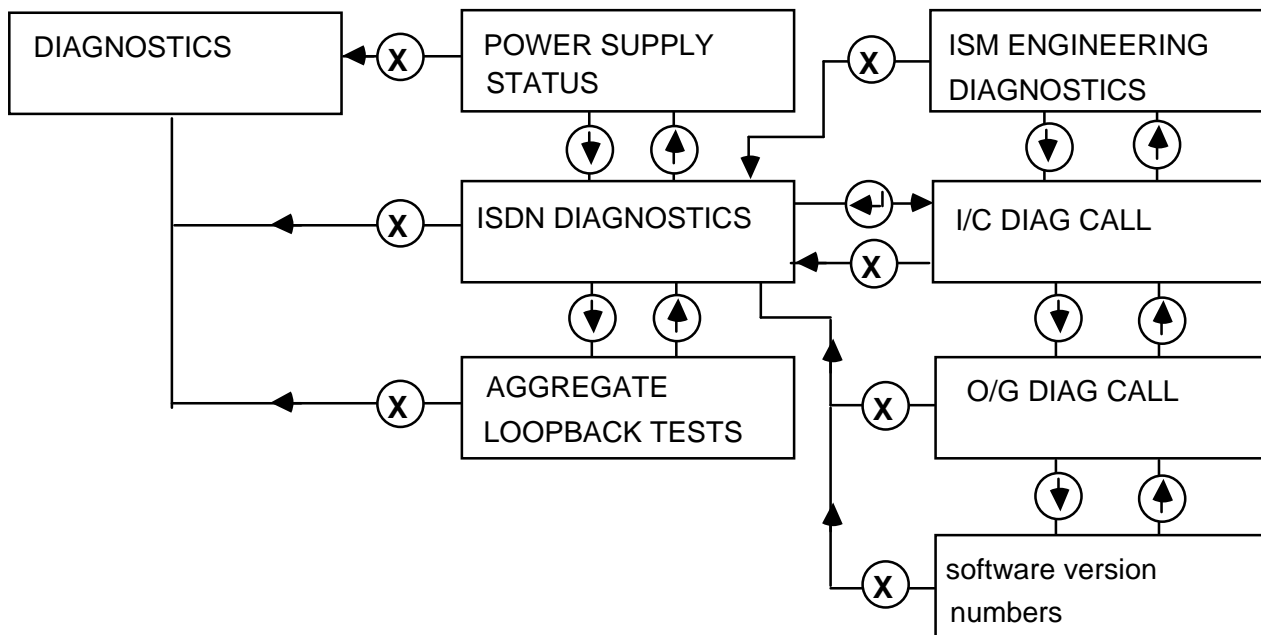

A multiplexer node can be configured to accept an incoming call as follows:

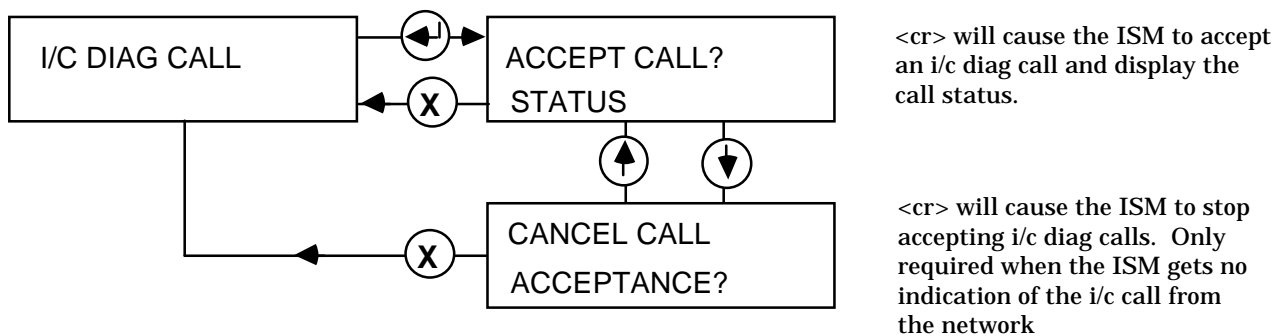

Outgoing diagnostics are instigated as follows. Note that the call will fail if the receiving multiplexer has not been configured to accept a call.

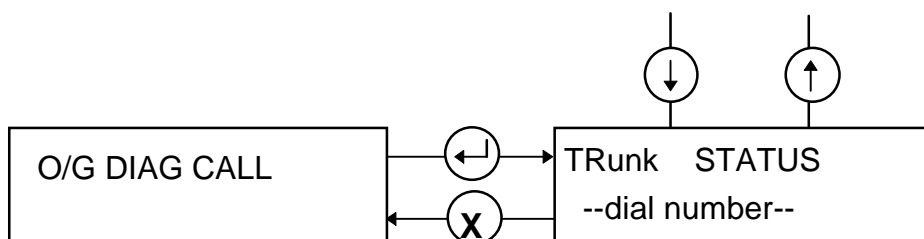

't' is the trunk number. The up and down arrows on the 'i' (index) field will step through the dial numbers for this trunk, automatically stepping on to the next or previous trunk from the last or first index.

<cr> will cause the displayed number to be dialled and the call status to be displayed.

Diagnostic calls are automatically cancelled as soon as they are established hence minimising line charges.

The call status for both outgoing and oncoming calls is updated dynamically as the status changes. The status displayed may be one of the following:

WAIT	ISM is preparing for the call
READY	The ISM is ready to accept an incoming call
DIAL	Dialling an outgoing call
OK	Incoming or outgoing call established successfully
NO CHA	Both channels are already allocated so the ISM can't accept or make a call
BUSY	For an o/g call, a busy (engaged) response was obtained from the remote ISM
NETWRK	The ISDN network is not available
FAILED	Call establishment failed for some other reason
TMO	Incoming call 5 minute time-out expired, incoming calls no longer accepted.
PASSWD	This indicates that the equipment at the other end of the ISDN is not an ISM. This response may also be the result of cancelling the call during the password exchange phase of call establishment.

The current software version number can be obtained as follows:

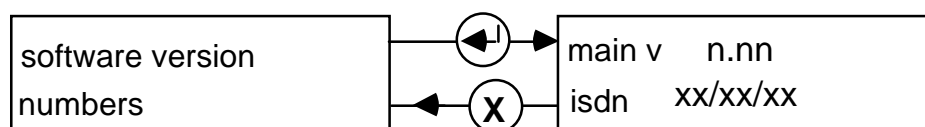

This displays the software version of the ISM MAIN code and the ISDN interface code.

## 9.2 ISM Engineering Diagnostics Menu

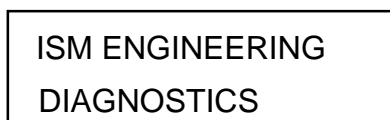

This menu is password protected and is only for use by Cray Engineering staff. It permits access to essential parameters of the ISM. Some features may cause severe disruption to the ISM functionality, hence it is not made

generally available. It is only mentioned here as the top menu is visible to the user.

Should the operator press the enter key on this menu they will be prompted for a password. If an incorrect password is entered, control returns to this menu.