

34/38/3900 Digital Multiplexers Operation Manual

© Case Communications Ltd 1997

X723-300051

0-1

Issue 3

Unit 15, Riverside Business Centre, Victoria Street, High Wycombe, Bucks HP11 2LT
Web: www.casecomms.com Email: sales@casecomms.com
Tel (UK): 08700 263 740 Tel (International): +44 (0) 1494 833 740
Fax (UK): 08700 263 741 Fax (International): +44 (0) 1494 833 741

STATUTORY NOTICES



Case Communications Ltd. declare that this product conforms with the requirements of the European Communities Council Directive of 73/23/EEC on the harmonisation of the laws of Member States to electrical equipment designed for use within certain voltage limits.

Case Communications Ltd declare that this product conforms with the protection requirements of Council Directive 89/336/EEC on the approximation of the laws of the member states relating to electromagnetic protection.

This equipment has been tested using shielded cables supplied by Case Communications Ltd. These cables, or equivalents, must be used to ensure compliance with this declaration.

All PCB assemblies contain Electrostatic Sensitive Devices (ESDs) which may be permanently damaged if incorrectly handled. This equipment must be handled in accordance with BS5783 code of practice for the handling of electrostatic sensitive devices.

Case Communications Limited has made all reasonable efforts to ensure the accuracy of the content of this document but the information contained herein does not constitute a warranty of performance of the equipment and/or software described and no specifications given form part of any contract. This document does not constitute a licence to use or copy any software described herein and any such software must only be used in accordance with the terms of the licence supplied herewith.

Case Communications Limited reserves the right to make alterations to the equipment and software described without notice and assumes no liability for any loss or damage caused as a result of use of this document whether because of out of date or inaccurate information or otherwise.

Product and manufacturers' names referred to in this document are used for identification purposes only and Case Communications Limited acknowledges the intellectual property rights of their respective owners in the same.

This document is the copyright of Case Communications Limited and may not be reproduced, copied or stored in any computerised retrieval system by any means without the express written permission of Case Communications Limited.

Published by Case Communications Technical Publications Department

STATUTORY NOTICES

WARNINGS

All PCB assemblies contain Electrostatic Sensitive Devices (ESDs) which may be permanently damaged if incorrectly handled. If PCBs are to be removed from the chassis, they must be handled in accordance with BS5783 code of practice for the handling of Electrostatic Devices.

The System Control Board DT300 contains a Nickel-Cadmium (NiCad) battery which contains toxic substances. The following instructions must be followed when handling or disposing:

- (i) Non-conductive anti-static bags must be used for transportation and storage of the board assembly.
- (ii) Care must be taken not to short-circuit the battery.
- (iii) The battery must not be disposed of on an open fire.

The earth stud on the rear of the equipment must be connected to earth.

The mains powered power shelf must be connected to earth via the power lead. Protective covers on this unit should only be removed by authorised personnel.

The DC powered power shelves must be connected to earth via the marked earth terminal.

The 3400 and 3800 must not be transported with the power supply units fitted to the chassis since this can cause dislocation of the card guides if the unit is subjected to impact

SAFETY

All interface ports in the multiplexer have a safety status of 'TNV' when a DT579, DT186, DTE063 or a DTE064 is installed or an external ringing supply is connected. In all other configurations the interface ports have a safety status of 'SELV'. This must be taken into account when connecting the equipment. For mains powered multiplexers, the socket outlet supplying this equipment must be installed near the equipment and must be easily accessible.

Czech Republic Statutory Notice

Prístroj musí byť umiestnen v blízkosti sít'ové zásuvky. K odpojení prístroje od siete slouží vidlice sít'ového privodu.

STATUTORY NOTICES

APPROVALS

The approval number for the 3400 and 3800 multiplexers is NS/3660/123/N/602896.

The approval number for the 3900 multiplexer is NS/3660/123/N/603326.

The equipment is approved for indirect connection to the PSN via the 4 wire E&M (SSDC5) PABX tie line ports and G.703 2048 kbit/s PABX ports and for direct connection to G.703 2048kbit/s and X.21 Nx64kbit/s 'Private circuits' subject to the following conditions:

- 1) WARNING. Interconnection directly, or by way of other apparatus, of ports marked:-
'WARNING. Connect only apparatus complying with BS6301 to this port'
or
'WARNING. Connect only apparatus complying with BS6301 to these ports'
with ports not so marked may produce hazardous conditions on the network. Advice should be obtained from a competent engineer before such a connection is made.
- 2) All ports are marked as shown in para 1, and other than those connected to Public Telecommunication Networks, may only have equipment complying with BS6301 connected to them.
- 3) Connection of power supply. This apparatus may only be used with Type 3000 power supply equipment. Other usage will invalidate any approval given to this apparatus if as a result it ceases to comply with BS6301:1982.
- 4) The primary DC power source for the equipment must be from a power supply complying with BS6301.
- 5) For voice frequency circuits the total power to line level must not exceed -13dBm.
- 6) Voice frequency circuits provided on channel interface cards DTE90 to DTE95 and DT515 may be indirectly connected via the isolation barrier DT290 to the PSTN or 'Leased lines'. This connection must be made in accordance with the instructions contained in the relevant operators manual for these cards.
- 7) Direct connections may only be made to NTPP ports from 2048 kbit/s PCM interfaces utilising the Dual Line Interface card DT310. The Dual V.11 Card DTE50 and the Dual Nx64k Card DT585, may be directly connected to 'Private circuits'.
- 8) Prevention of access by user. If a Ringing Generator is fitted in the chassis or an external ringing supply is connected or 2Wire Loop Disconnect cards are fitted, the following applies: This apparatus is intended to be accessible only to authorised personnel. This apparatus must be installed in a locked room or similar environment. Failure to prevent such user access will invalidate any approval given to this apparatus.

ENVIRONMENTAL

The apparatus is not intended to be operated under controlled conditions of ambient temperature and humidity.

Contents

1	Equipment Detail	1-1
1.1	General Description	1-1
1.2	Multiplexer Facilities	1-4
1.2.1	Control of the Multiplexer	1-4
1.2.2	Control Terminal Operating Modes	1-4
1.2.3	Configuration Fields	1-5
1.2.4	Fault Reporting	1-10
1.2.5	Real Time Clock	1-11
1.2.6	Maintenance Facilities	1-11
1.3	Mechanical Description	1-13
1.3.1	3400 Description	1-13
1.3.2	3800 Description	1-16
1.3.3	3900 Description	1-18
1.4	Specifications	1-20
1.4.1	Common Equipment	1-20
1.4.2	Dual LIU Line Signal Characteristics	1-20
2	Installation and Commissioning	2-1
2.1	General	2-1
2.1.1	Modes of Operation	2-2
2.1.2	Commands and Control Characters	2-2
2.1.3	Special Input Control Characters	2-3
2.1.4	General Conventions for Verbose Prompts and Messages	2-3
2.2	Installation	2-4
2.2.1	Unpacking	2-4
2.2.2	Mounting	2-4
2.2.3	Power Connections and Earth Bonding	2-5
2.2.4	Alarm and Control Wiring	2-7
2.2.5	PCM and Clock Connections	2-9
2.2.6	Data Wiring	2-9
2.2.7	Network Management Connections	2-10
2.2.8	Local Port Connections	2-10
2.2.9	Ringling Voltage Connections	2-11

2.3	Commissioning	2-13
2.3.1	Link and Switch Settings	2-13
2.3.2	Switch on Procedures	2-14
2.3.3	Initial Multiplexer Set-up	2-14
2.3.4	Alarm Indicators	2-15
3	Dual Line Interface Unit	3-1
3.1	General	3-1
3.1.1	TS0 Not Frame Word Routing	3-1
3.1.2	Clock Recovery and Selection	3-3
3.1.3	Jitter Attenuation	3-3
3.1.4	Frame Structure	3-3
3.1.5	G.703 Clock Output	3-3
3.1.6	Link Settings	3-4
3.1.7	Switch Settings	3-4
3.1.8	LED Indicators	3-4
3.2	Dual LIU Adapters	3-5
3.2.1	DT315 75 Ohm I/O Adapter	3-5
3.2.2	DT316 120 Ohm I/O Adapter	3-5
4	Management Configuration	4-1
4.1	Introduction	4-1
4.2	System Controller Patchfield	4-2
4.3	Dual LIU Patchfield	4-2
4.3.1	Cross-connect Bits	4-3
4.4	Examples of Management Patchfields	4-3
5	Multiplexer Configuration	5-1
5.1	Menu Tree	5-1
5.1.1	Menu Operation	5-1
5.1.2	Root Menu	5-2
5.1.3	Time Menu	5-2
5.1.4	Mode Menu	5-2
5.1.5	Configuration Menu	5-3
5.2	Time Menu	5-4
5.2.1	Time and Date Setting	5-4
5.2.2	Time and Date Display	5-4
5.2.3	Timed Events	5-4
5.3	System Mode Menu	5-7
5.3.1	Brief and Verbose Mode Selection	5-7
5.3.2	Echo and No Echo Selection	5-7
5.3.3	Control Terminal Configuration	5-7

5.3.4	Install Menu. E ² PROM programming	5-8
5.3.5	Security Password Modification	5-12
5.4	Configuration Menu	5-13
5.4.1	Checking and Running Channel Configurations	5-13
5.4.2	Editing and Displaying Channel Configurations	5-13
5.4.3	Port 1 and Port 2 Dual LIU Configuration	5-14
5.4.4	Sync Source	5-20
5.4.5	Alarm Events, Route Alarms, External Relays and Card Out	5-21
5.4.6	Circuit Assignments	5-25
5.4.7	Circuit Controls	5-26
5.4.8	Smart Configurations	5-26
5.4.9	Fixed Code Table	5-27
5.4.10	Cross Connection Configuration	5-28
5.4.11	Fixed Data Assignment	5-32
5.4.12	Multipoint Timeslot Assignment	5-32
5.4.13	Cross Connect Broadcast Display	5-33
5.4.14	Edit Buffer Origin Display	5-33
5.4.15	Checking and Running Management Configurations	5-33
5.4.16	Management Configuration Linking	5-34
5.4.17	Equipment Map Editing	5-34
5.4.18	Default Configuration	5-36
5.5	Remote Menu	5-39
5.5.1	Operation (Non-Network Mode)	5-39
5.5.2	Operation (Networking Mode)	5-39
5.6	Smart Menu	5-40
6	Fault Reporting and Maintenance Facilities	6-1
6.1	Fault Reporting	6-1
6.1.1	Fault Logging Modes	6-2
6.1.2	Fault Store Listing and Clearance	6-2
6.1.3	Displaying Active Faults	6-2
6.1.4	Inhibiting Circuit Alarms	6-2
6.1.5	Received Attention	6-3
6.1.6	Fault Tables and Alarm Responses	6-5
6.1.7	Statistical Reports	6-9
6.2	Maintenance Facilities	6-11
6.2.1	Current Status Monitoring	6-12
6.2.2	Setting Data and Signalling	6-13
6.2.3	Displaying Data, Signalling and Peak Codes	6-14
6.2.4	Loops. Setting and Clearing	6-14
6.2.5	Running Self Test	6-17

6.2.6	Alarm Relay Setting and Clearing	6-18
6.2.7	System LED Test	6-18
6.2.8	Equipment Type and Version Display	6-19
6.2.9	Manual A/B Switching	6-19
6.3	Network Problems	6-20
6.4	Built-in Test Facilities	6-21
6.5	NCS Fault Levels	6-23
7	Channel Interface Cards	7-1
7.1	General Information	7-1
7.2	Approvals	7-3
7.3	Interface Card Reference Numbers	7-4
Appendix A	Patchfield Electrical Diagrams	A-1
A.1	General Information	A-1
	System Controller Patchfield DT990C	A-2
	Dual LIU Patchfield DT995D	A-6

Figures

1-1	Typical System Block Diagram	1-3
1-2	Typical Multipoint Configuration	1-10
1-3	Front View of the 3400 Multiplexer	1-14
1-4	Rear View of the 3400 Multiplexer	1-15
1-5	Front View of the 3800 Multiplexer	1-17
1-6	Front View of the 3900 Multiplexer	1-19
2-1	Backplane Ringer Sections	2-12
4-1	Management Patching Block Diagram	4-7
4-2	Networking Patchfield Example	4-10
4-3	Local/Remote Patchfield Example	4-10
5-1	Timeslot Check Diagram for Nx64 Operation	5-31
6-1	Position of Loops and Data Test Points	6-17

Tables

2-1	Alarm Connector Pin Connections	2-8
2-2	Network Port Pin Connections	2-10
2-3	Local Port Pin Connections	2-10
2-4	Backplane Links	2-12
2-5	System Controller SW1 Switch Settings	2-13
2-6	Local Port Baud Rate Switch Settings	2-13
4-1	System Controller Patchfield DT990A	4-8
4-2	Dual LIU Patchfield DT995D	4-9

1.1 General Description

This manual applies to 34/38/3900 units fitted with operating firmware DT981/6. Dual Line Interface Units fitted to ports 1 and 2 must be fitted with DT986/2 or later firmware.

These multiplexers are a software controlled multiplexer and switch, providing multiplexing of voice and 64 kbit/s data circuits in to 2048kbit/s, or 1544kbit/s PCM streams, and Nx64kbit/s X.21 lines. The unit is capable of accessing up to four PCM streams, via Port 1 and Port 2, allowing multiplexing of data on to any stream and cross-connection between streams. The unit may be operated as a 30 channel system (CAS mode) or as a 31 channel transparent system (CCS mode). Multiplexing and cross-connection is performed on a timeslot basis. Additional PCM streams can be provided with some restrictions on cross-connectivity due to backplane 2Mbit/s bandwidth limitation in Port 3 and Port 4.

The multiplexer utilises a microprocessor based system control card for data cross-connection, synchronisation, general supervision, and the user interface. The user interface takes the form of a menu tree presented on a standard RS-232 port.

Interface connections to the multiplexers are by Dual Line Interface Units (2048kbit/s), T1 Line Interface cards (1544kbit/s) or Dual Nx64kbit/s cards for the trunk lines, and by a range of channel interface cards for voice and data circuits. Information on the interface cards is contained in separate manuals for each card. Some channel cards are also microprocessor based and have a user interface which is presented via the system control card. Such cards are called 'Smart' channel cards, and the user gains access to these via the 'Smart' interface option provided by the system control card.

The 2048kbit/s PCM line signal interfaces to a Dual LIU in the multiplexer. This card can operate as either a smart channel card when fitted in Port 3 or Port 4, or integrate with the system control card to present one user interface when fitted in Port 1 or Port 2. A separate manual contains information on the Dual LIU operating as a smart channel card. The Dual LIU works in conjunction with a G.703 I/O adapter (75R or 120R) to provide interfaces to two G.703/G.704 line

signals with optional bypass facilities. A G.703 synchronisation port is also provided.

The G.703 I/O adapters used with the Dual LIU provide the option of supporting a PCM and clock bypass. This is used to link the two line signals in the event of a power failure or a fault in the multiplexer.

The 3400 and 3800 chassis may be equipped with up to thirteen channel cards. The 3900 chassis may be equipped with up to five channel cards.

Channel cards are used to interface to 64 kbit/s data circuits or voice circuits. A variety of channel cards are available including 2/4 wire voice cards V.11, V.35, X.21, Nx64k and RS-232 interfaces.

Each channel card circuit can be assigned to any timeslot, and cross-connected to any other timeslot. Additional PCM interface cards are available for the connection of tributary PCM streams. All channel cards for the multiplexers are fully interchangeable with other Series 3000 multiplexer products, and Series 2000 with a few operational restrictions in some cases.

Ports 1 and 2 each have one physical card slot, and 3 x 32 timeslot backplane busses allocated to them. In port 1 these backplane streams are referred to as P1, S1 and S2 for configuration purposes. In port 2 these backplane streams are referred to as P2, S3 and S4 for configuration purposes. When a Dual LIU or Dual NX64 Kbit/s card is inserted into Port 1 or Port 2, they automatically use S1, S2 or S3, S4 in busses in port 1 and 2 respectively. This allows access for cross connection on the system controller of all 4x31 timeslots of 4 x 2Mbit/s PCM stream when a Dual LIU is fitted in Port 1 and 2 for example. When standard channel cards are fitted in Port 1 and Port 2, they automatically use P1 or P2 busses in Port 1 and Port 2 respectively. In some cases, they have 32 timeslots available for cross connection at the system controller.

Port 3 has six physical card slots in a 34/3800, and 2 in a 3900. Port 3 in all chassis has 1 x 32 timeslot backplane bus allocated to it which referred to as P3 for configuration purposes.

In a 34/3800 Port 4 has five physical card slots, three if a redundant power supply is fitted. In a 3900 there is only one. Port 4 in all chassis has 1x32 timeslots backplane bus allocated to it which is referred to as P4 for configuration purposes

A typical system block diagram is shown in Figure 1-1. If further PCM line interfaces are required, it is possible to fit Dual LIU cards in Ports 3 and 4, with the restriction of 31 timeslot access to each port.

The 3400 chassis can incorporate up to four 2048kbit/s G.703 to optical fibre conversion modules and a 35 Watt ringing generator in the rear of the chassis. Details of the optical modules can be found in the relevant manual.

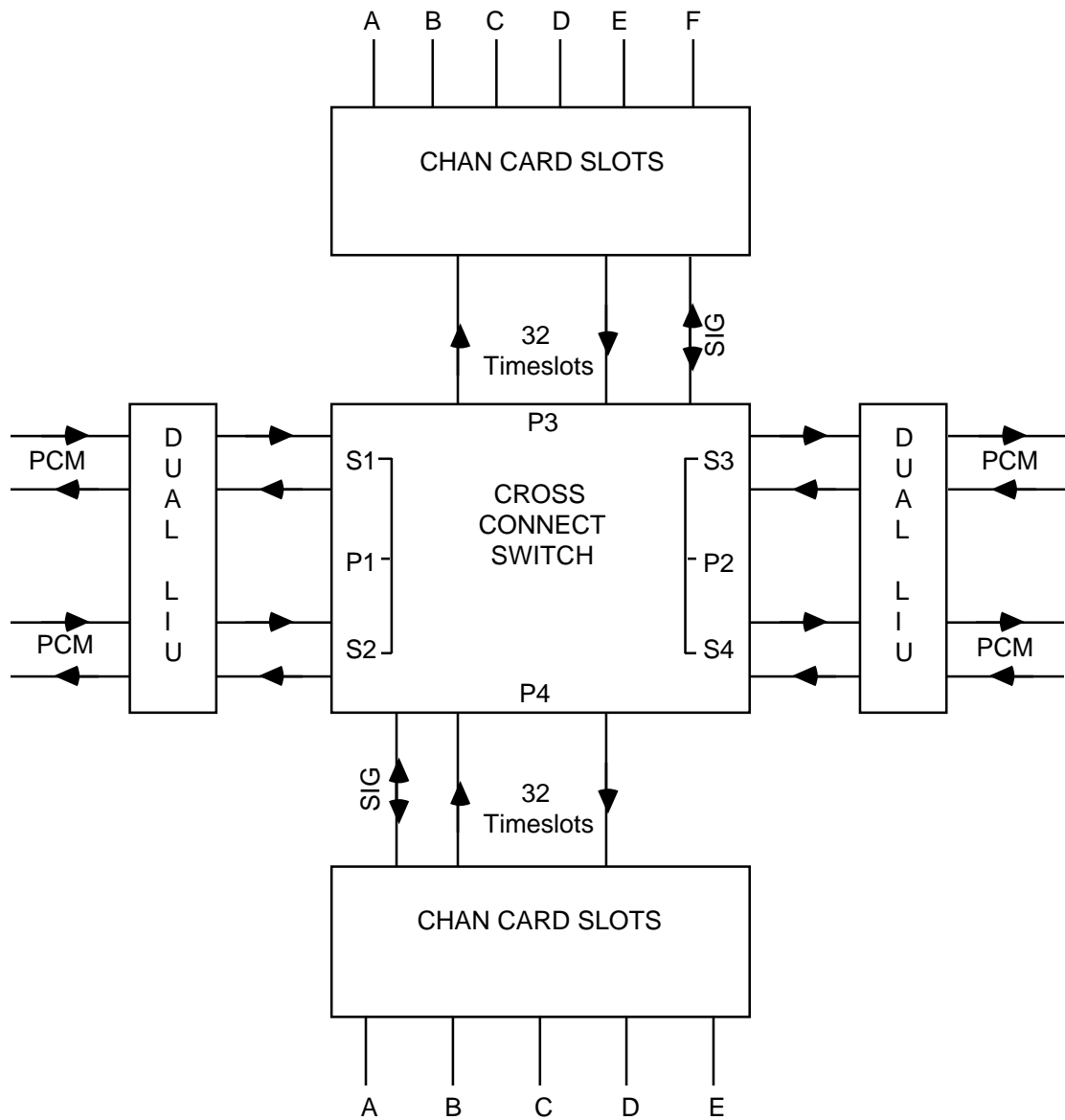

Figure 1-1 Typical System Block Diagram

1.2 Multiplexer Facilities

1.2.1 Control of the Multiplexer

The system controller supports an RS-232 port for connection to a standard ASCII VT100 VDU. This is used for local control and maintenance purposes. Password protection can be used with this port for increased security.

Two or more multiplexers may be operated in Local/Remote mode where control of all multiplexers may be carried out from a VDU connected to one unit, this is termed the 'local unit'. Control of the 'remote unit' is usually via spare bit capacity in TS0 or by V.28 connections and a suitable data link between the two units.

The Network Control System (NCS) may be used to control up to 500 multiplexers in a network, and also provides node to node control and messaging facilities.

The system control card supports a Real Time Clock and non-volatile battery backed RAM with a retention time of approximately 2 weeks for storage of cross-connect mappings, fault logs etc. In addition an E²PROM is used for long term storage of the multiplexer Mode Install settings. Note that if the firmware level is changed the contents of the RAM may be lost.

1.2.2 Control Terminal Operating Modes

The multiplexer may be set to operate with a wide range of RS-232 terminals e.g. Wyse 50 compatible VDUs, Teletypes, Personal Computers etc. A Brief and Verbose operating mode is available.

A menu tree is used to control the set-up and configuration of the equipment which is normally used in verbose mode displaying all text. In brief mode, all menus operate normally except for the text output which is restricted to prompts, and fault numbers during fault reporting. Brief mode is provided for factory test purposes, or fast access by experienced users using pre-prepared configuration scripts controlling a communication package running on a Personal Computer for example.

An Installation set-up facility is provided to configure the equipment to suit each installation, this contains items such as the 'power-on' default settings, whether the NCS is to be used and other operational parameters.

1.2.3 Configuration Fields

The multiplexers support Channel, Smart and Management configurations.

Channel configurations cover the set-up of all the channel cards, the Dual LIUs when fitted in ports 1 and 2, synchronisation plus the cross-connect mappings on the system controller.

There are 14 channel configurations which are stored in non-volatile RAM and edited in an edit buffer. A default configuration is programmed into the software to ensure a valid fallback configuration is always available. Any one of the 14 configurations may be selected and run.

Smart configurations are used by smart channel cards to store their configuration data. This data is produced by the smart card but stored in the system controllers non-volatile RAM. Each smart card can generate up to four smart configurations. For each channel configuration a smart card can be instructed to run any one of its four configurations.

Management configurations are used to control the routing of the Network management data across the PCM TS0, not frame word, and to the system controller network ports and management UARTS.

Fourteen management configurations are provided, each can select different routing options for PCM TS0 not frame word on the Dual LIU or V.28 ports on the system controller. A management bus is used to allow all the cards in the system to exchange management data. The management routing is controlled by a series of pre programmed patchfields on system controller and Dual LIU, which may be selected to provide the required configuration.

Equipment Map

A feature of the multiplexers is the equipment map. This is provided to allow the equipment to register which channel cards are fitted. In addition the equipment map is used to raise an alarm if a mapped channel card is removed or replaced with an incompatible card. Cards which are not mapped in will not report faults to the system controller but will still function.

Configuration Options

Dual LIU Configuration Options

When fitted in port 1 or 2, the Dual LIU is configured from the Channel configuration options.

The following are selectable for each PCM line:

- Multipoint mode:** when selected, timeslots are connected directly between the 2 line interfaces on the dual LIU, by-passing the cross-connection of the system controller. This can be useful in minimising delays in a network. Individually selected timeslots from either line may be dropped/inserted to the cross connect switch in either duplex or multipoint.
- Terminal mode:** when selected provides two independent PCM trunks to the cross connect switch.
- A/B mode:** when selected provides a route protection scheme for the line signal.
- Signalling mode:** this selects Channel Associated Signalling (CAS), or 31 timeslot mode transparent to Common Channel Signalling (CCS).
- Fault logging:** unused lines may have their alarms inhibited to avoid unnecessary fault logging. When inhibited the fault responses to the line (remote frame and multiframe alarm bits) will not be affected.
- TS0 routing:** it is possible to route the spare bits in TS0 either to the management patchfield or to the cross-connect switch to provide management routing and Remote alarm bit routing.
- PCM Bypass:** this allows the Dual LIU to be taken out of service by activating the bypass relays on the I/O adapter. This facility may be used where a standby LIU is fitted but not in service.
- CRC4:** Provides error performance monitoring using CRC4. It may be enabled or disabled.

Low error rate threshold: this allows thresholds of 1 in 10^{-4} , 1 in 10^{-5} , or 1 in 10^{-6} to be used to raise an alarm. Note that this does not affect the detection of 1 in 10^{-3} error rate required for line service monitoring.

Synchronisation Options

The Series 3000 can be synchronised to a 2MHz or two 8 KHz, known as 8k1 and 8k2, internal clock busses which are generated by certain channel cards by recovering a phase locked clock from external interfaces. Access to the 2MHz clock bus is fully controlled by the system controller. However, access to the 8Khz busses are not. This is controlled by link selection on the channel cards. Thus, care should be taken to ensure only one channel card is connected to each of the 8Khz clock busses at any one time. The Dual LIU supports the 2MHz clock bus which allows the multiplexers to be synchronised to a PCM stream or external G.703 clock.

A prioritised list may be set up to give a primary sync source plus 4 fallback sources. The lowest priority source is always the internal free-run oscillator. All clock sources are checked for frequency, and internal timers may be invoked to avoid spurious switching between intermittent sources. Sync sources from the PCM line signal recovered timing are also qualified against various line signal fail options.

Note: A PCM line signal should not normally be used as the sync source if it has its fault logging inhibited since failure of the line will not be reported.

Alarm Event Options

An 'Alarm Event' may be used to trigger a change of configuration in response to failure of either the incoming data paths or to a failed channel card. These are used to provide automatic re-routing of services affected by any failures.

For each multiplexer configuration, each alarm event source can be programmed to run a different multiplexer configuration in the event of failure, allowing recovery plans to be set-up for multiple failures.

Configuring Channel Cards

Channel cards in each port are identified by a letter e.g. P1A, (Port 1 card A), P3B (Port 3 card B). Each channel card can support up to four independent circuits numbered 1 to 4 e.g. P4A2 (Port 4 card A circuit 2).

Some channel cards can provide eight circuits and circuit allocation is described in the relevant channel card manual.

Cards with only 1 circuit will only support circuit 1, and dual cards will only support circuits 1 and 2.

Timeslot Assignment

Each channel card circuit may be assigned a timeslot(s) from the 32 available in each port stream (P1, 2, 3 and 4).

Each port stream timeslot has associated with it an 8-bit TS control byte, this is used to control the gain of the A-D D-A converters on VF channel cards for setting the analogue interface levels. It is not used on data cards.

Timeslot assignment is not required for a Dual LIU in port 1 or 2. The Dual LIU automatically connects Line 1 timeslots to S1(3) timeslots, and line 2 timeslots to S2(4) on a fixed one to one basis, i.e. line timeslot 1, 2, 3,.....31 to S bus timeslot 1, 2, 3,.....31.

Circuit Controls

Each channel card circuit supports two 8-bit control ports. These are used to control operating modes, data rates and loops etc. The settings of these ports will vary from card to card.

Smart Configurations

Smart cards support two or four configurations. The channel configuration maps which configuration any individual smart card will run for each of the multiplexer main configurations.

Fixed Codes

Fixed codes are used when cross-connection of data and signalling is not required or not possible e.g. due to line failures etc.

A table of 16 combinations of user programmable fixed data and signalling codes is maintained. Each source timeslot may call up any one of these codes to be used to replace its data and associated signalling.

Cross Connect Assignments

The cross-connect path may be set up for each outgoing timeslot from the cross connect block on the system controller. Note all backplane data

streams are terminated or sourced from the cross connect block on the system controller. In each case the source stream/port, timeslot, mode, and fixed code is defined. Alternatively a fixed data mode may be used without any cross-connections.

Cross-connection modes supported are:

Simplex: for uni-directional and broadcast data.

Duplex: for bi-directional data.

Multipoint: for point to multipoint services via the cross-connect switch.

To 'undo' a cross-connection it is necessary to allocate fixed data to the outgoing timeslot. If the connection was in duplex it is necessary to individually allocate fixed data to each outgoing timeslot, this is because a duplex connection, for example P3, TS 1 to P4, TS2 sets up 2 simplex connections for the two outgoing timeslots, P3 TS1 to P4, TS2 and P4 TS2 to P3 TS1.

Multipoint allows timeslots from Port 3 (P3) to be 'ANDed' together with incoming data from any backplane stream, the result is then inserted in to the outgoing backplane stream. This allows timeslots, hence circuits that support Multipointing, to be cascaded together such that all of them can insert and drop data from one timeslot. The end of the chain is referred to as the master and is connected to many slave cards. The master usually broadcasts data to all slaves. For correct operation only one slave may be active i.e. inserting data at a time. While inactive, the slave should insert 'all ones' towards the AND gate, thereby allowing data from the active slave to pass through.

Currently multipoint cards exist for X.21, Dual V.24 and 2/4 wire voice circuits. For multipointing to operate a channel card must *not* be fitted in port 1; it may be fitted with a Dual LIU or left empty.

Programmable fixed codes are not available for multipoint mode. In this case an 'all ones' data pattern will be generated under fault conditions in each timeslot affected.

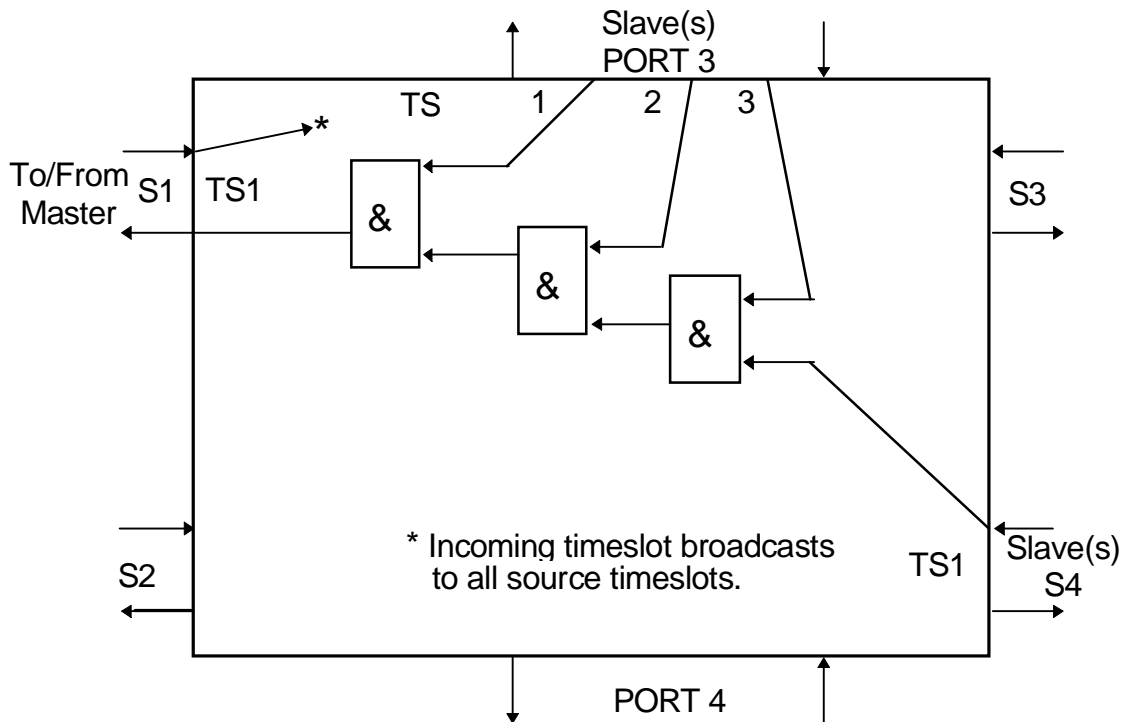

Figure 1-2 Typical Multipoint Configuration

1.2.4 Fault Reporting

The multiplexers have comprehensive fault reporting facilities. All faults are logged, as messages, in a fault store (capable of storing the last 64 faults) to show the fault history, as well as being held in an active faults list to show current faults.

Fault messages from smart channel cards will also appear in the fault store, however the smart card also maintains its own active fault list. Smart channel cards also control the system controller alarm relays.

Fault stores may be accessed locally by the RS-232 port, or remotely with the NCS.

All faults have associated alarm LED, and relay actions. The alarm relay responses can be inhibited by the user acknowledging the alarms with 'Receive Attention' facilities.

Smart channel card faults have a separate 'Receive Attention' facility.

Each fault has an associated fault level, which is used by the NCS to process network faults, and is not available for display at the equipment.

Fault messages may be displayed directly on the local RS-232 terminal as the faults occur, or an Alarm Service Request (ASR) mode may be

selected. In ASR mode, fault messages are not automatically displayed, instead an ASCII BELL character is sent to the terminal every minute until the user manually requests the new fault messages to be displayed. A printer may be attached to the terminal to print out the faults as they are displayed.

Fault reporting from channel card circuits may be inhibited with a menu facility, or by removing the channel card from the equipment map which will inhibit all fault reporting for that card.

1.2.5 Real Time Clock

The multiplexers are equipped with a Real Time Clock. This is used to time and date stamp fault reports and also to log any messages received from the NCS.

A timed event facility is provided. This facility allows the multiplexer to automatically change configuration at pre-determined time points, allowing, for example, voice by day, data by night operation. The time points may be on a weekly or daily basis over a 365 day period with the provision to program up to 32 different event changes.

1.2.6 Maintenance Facilities

The multiplexers support comprehensive maintenance facilities as follows:

Current Configuration and Channel Card Status Display

Each non Smart channel card circuit supports two 8 bit status ports. These are used to indicate the channel card fault status, card identity code and set -up. These ports can be useful in identifying the nature of any active faults.

All configuration parameters may be displayed using the 'Configuration' menu and in the 'Maintenance' menu, status port values for the channel cards along with the current sync source and configuration running may be displayed.

Set and Display Data

Any outgoing timeslot, or its associated signalling, may be set to a user defined code, and any fixed incoming data or signalling may be displayed on the local terminal. These are powerful facilities designed to easily test circuit integrity in conjunction with various loopbacks.

Display Peak Codes

The data display can only display fixed unchanging data patterns which is therefore not suitable for checking analogue encoded circuits. A 'Peak codes' display allows the digital code of an analogue signal, and its equivalent power level to be displayed for any incoming timeslot.

The circuit must be coded to CCITT G.711 A law for this to operate correctly.

Loopbacks

Various loopback facilities are provided to aid circuit testing.

Local loops; loop the PCM line signal back to the multiplexer.

Incoming loops; loop the PCM line signal back to the line.

Timeslot loops; loop individual timeslots back to their source.

Circuit loops; activate loops on data channel cards. Generally these are bi-directional loops to CCITT. X.150

1.3 Mechanical Description

1.3.1 3400 Description

The 3400 is housed in a 19 inch 6RU chassis assembly. The chassis is fitted with a front panel which is designed to give protection against electrostatic discharge and should be fitted at all times when the equipment is in service.

All electrical connections are made on the rear of the equipment. A cut out in the front panel allows viewing of equipment status LED indicators of the System Controller, and access for connection of a control VDU.

With the front panel removed the chassis provides for the mounting of up to 15 printed circuit boards. The extreme left-hand position is for the system control card marked Syscon. The extreme right hand position is for the power supply unit, marked PSU A. Optionally a second PSU may be fitted in the adjacent position marked PSU B, however this prevents use of the last 2 card positions of port 4.

On the rear of the chassis there is provision to fit up to four fibre optic line driver modules and one Ringing Generator DT186.

All input/output connections to the channel cards are made via connectors on the rear of the unit. These connectors are designed to be optionally fitted with a universal I/O adapter (DT280) or DIN 41612 connector (see Section 2.2.6).

Up to 13 channel cards may be fitted in the positions marked P1, P2, P3A to P3F and P4A to P4E.

A front view of the equipment is shown in Figure 1-3 and a rear view in Figure 1-4

Power is supplied to the chassis via the rear power I/P panel. A terminal block is fitted to the back panel for the connection of an external ringing supply (see Section 2.2.9). Two connectors are mounted on the top right hand corner, the top connector, a 9-pin D-type, is used for V.28 Network Management (see Section 2.2.7). The lower connector, a 37-pin D-type, is used for Alarm inputs and Alarm relay contacts (See Section 2.2.4).

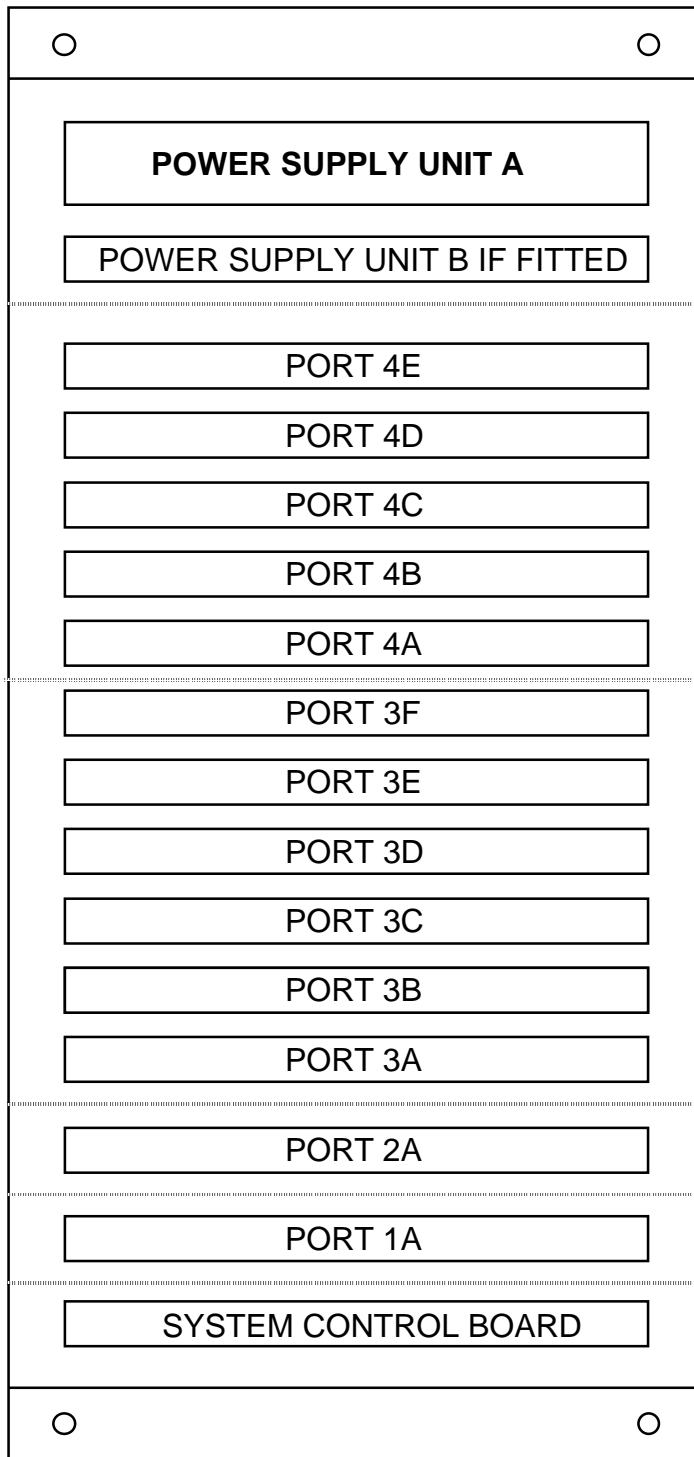

Figure 1-3 Front View of the 3400 Multiplexer

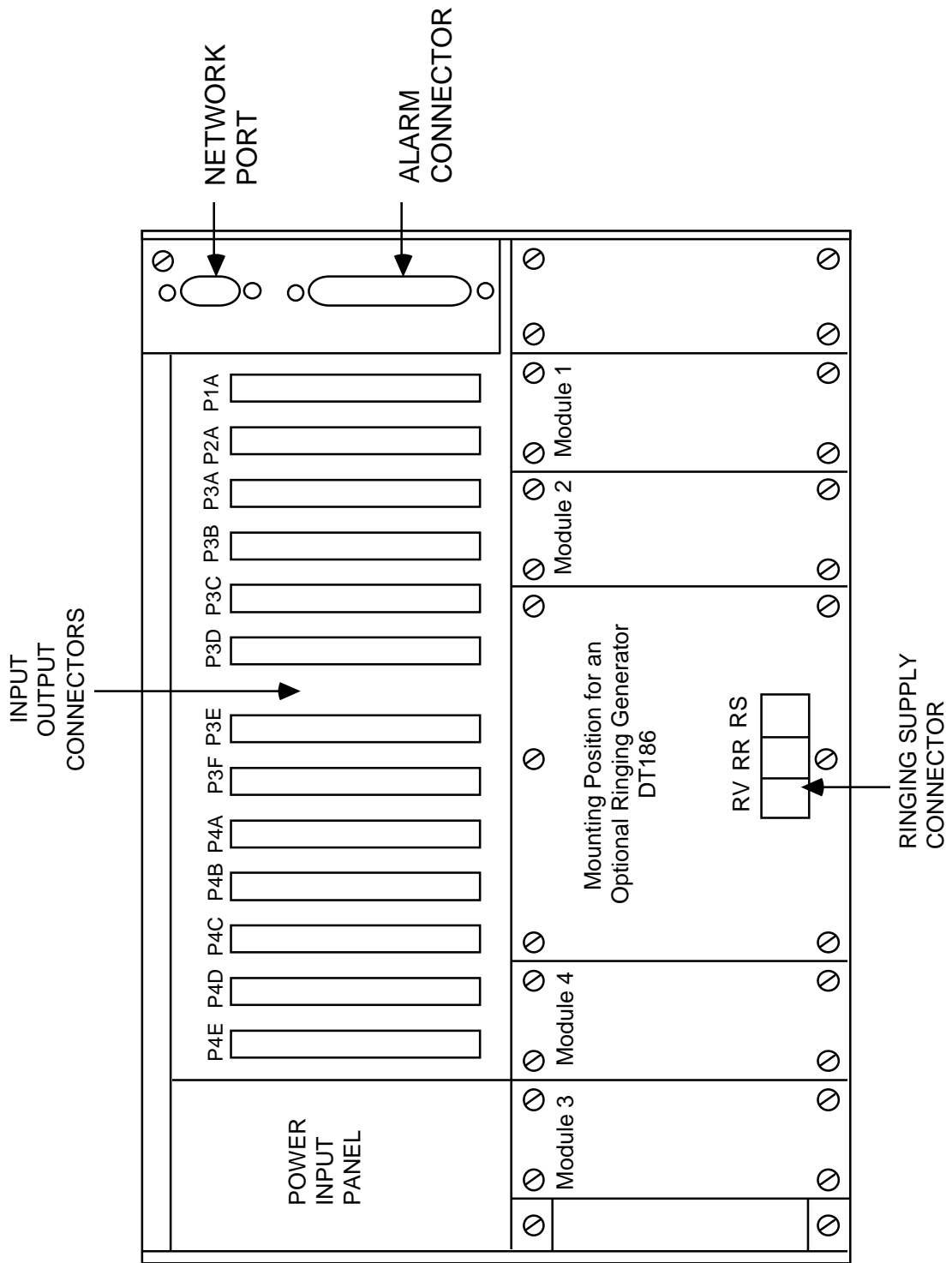

Figure 1-4 Rear View of the 3400 Multiplexer

1.3.2 3800 Description

The 3800 multiplexer is identical to the 3400 except that all external connections are provided on the front of the unit, and there is no provision for fitting fibre optic line driver modules or ringing generator DT186.

The chassis may be front, rear or mid mounted by changing the position of the side mounting angles.

Rear mounting may be used to secure the chassis against a wall. Front and mid mounting may be used with suitable 19" enclosures or racks.

The chassis is a 9RU assembly with the I/O connectors mounted above the card cage.

A front view of the equipment is shown in Figure 1-5.

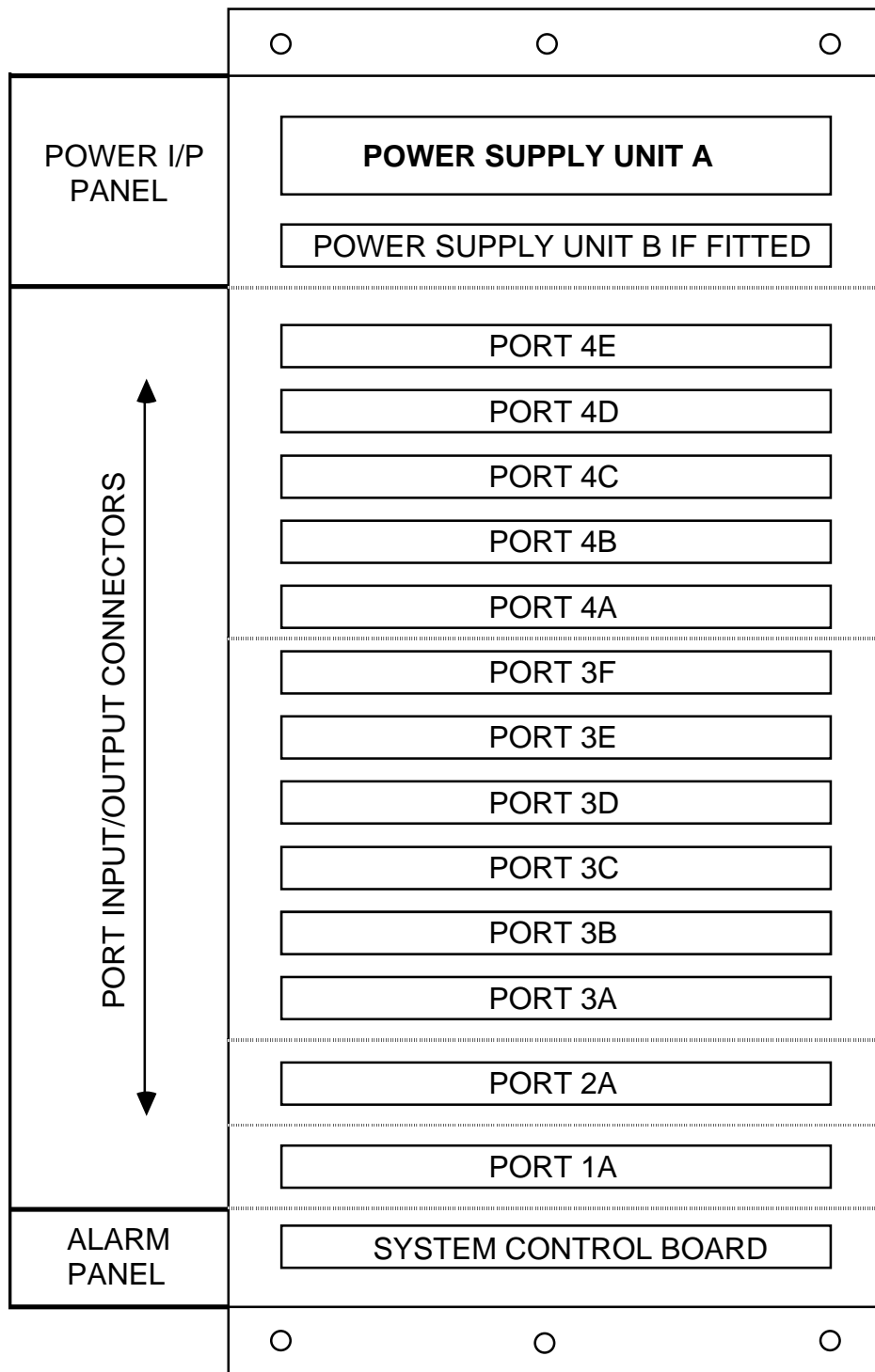

Figure 1-5 Front View of the 3800 Multiplexer

1.3.3 3900 Description

The 3900 multiplexer is a 4RU (176mm), 19 inch front access assembly which may be mounted in any orientation with adjustable mounting brackets providing rear, middle or front mounting positions. A front view of the multiplexer is shown in Figure 1-6.

The card slots for ports 1 and 2 may be equipped with Dual LIU cards or Channel Interface Cards. Port 3 has only two (2) card slots and port 4 has only one (1).

The power input panel provides for the connection of a -48VDC and ringing voltage for the back plane.

Connections to the power supply units is directly to the front of the PSU which has an on/off switch.

One Ringing Generator DT579 may be fitted in any port position to supply ringing voltage to all other ports. The backplane has no isolation links. An external ringing supply may be connected to the RV and RR terminals of the power input panel.

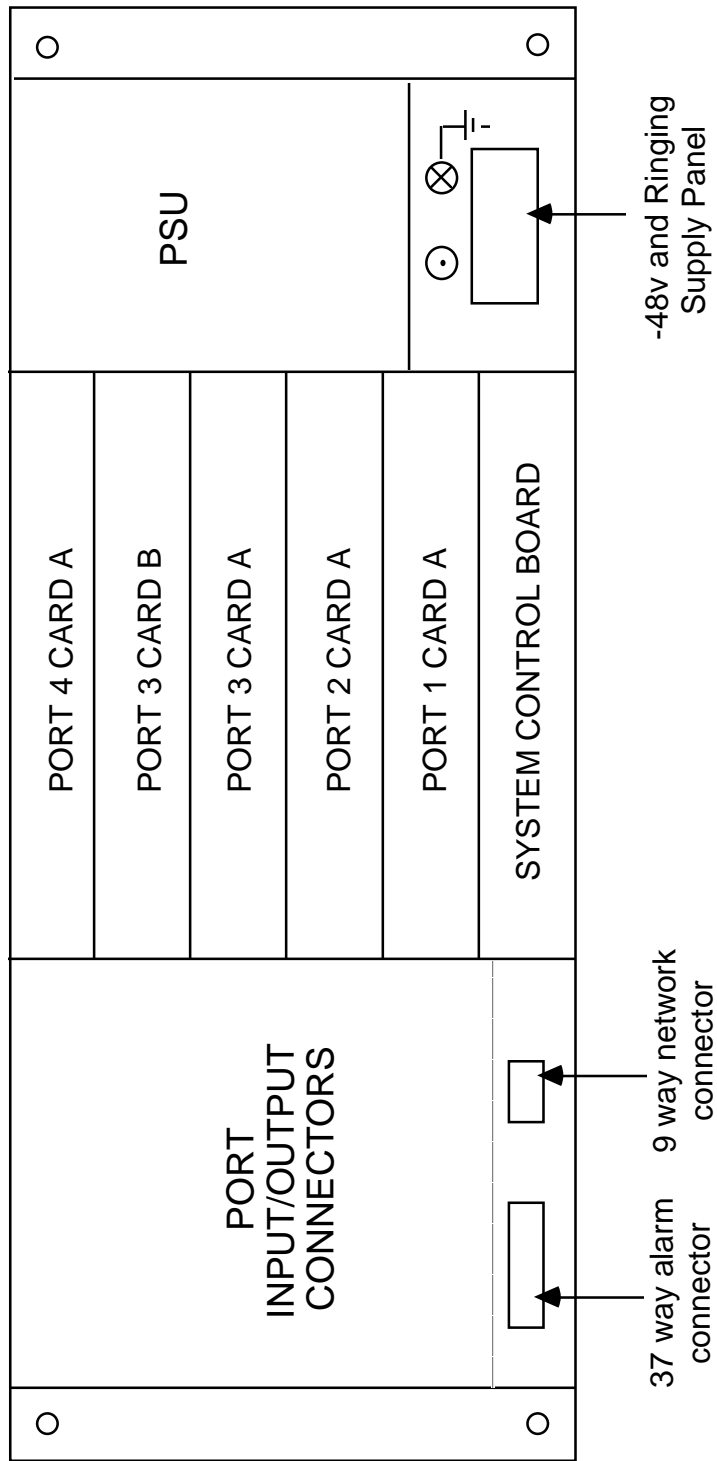

Figure 1-6 Front View of the 3900 Multiplexer

1.4 Specifications

1.4.1 Common Equipment

Complies with the relevant sections of:

CCITT G.703, G.704, G.706, G.732, G.736, G.823 (Blue Book).

BS6527 1988 Class A) Emissions

EN55022) " "

IEC801 Part 2 Level 3 ESD (8KV)

IEC801 Part 3 Level 2 narrow-band susceptibility (3V/m)

IEC801 Part 4 Level 2 electrical fast transients/bursts (1KVAC Power, 0.5KVDC Power Signal and Control)

Note: I/O adapters DT280 plus I/O blanking panels must be used for EMC compliance.

1.4.2 Dual LIU Line Signal Characteristics

- Line Rate: 2048kbit/s
- Stability: ± 25 ppm over 5 years when free running
- Line Code: HDB3
- Transmit Signal Level: $\pm 2.37V \pm 10\%$ (75 ohms)
 $\pm 3V \pm 10\%$ (120 ohms)
- Receive Signal Level: 0 to > 6dB line loss
- Line Interface: 75 ohms unbalanced: BNC Coaxial
120 ohms balanced: 9-way D-type connector

Jitter Transfer

When a Dual LIU (DTE241) recovered 2048kHz timing signal is selected as the system timing source, the jitter transfer from input to output does not exceed the following limits:

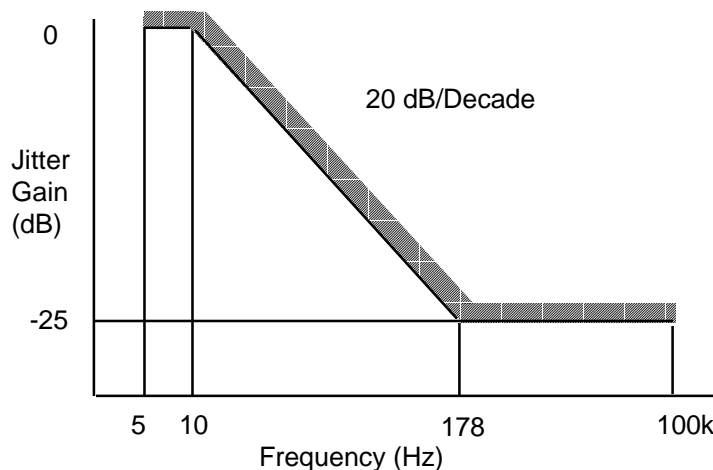

Power Consumption

System Controller with one Power Supply Unit.	30 Watts
System Controller with two Power Supply Units.	51 Watts

Plus the power consumption of the Dual LIU cards and other channel cards fitted (See relevant card manuals).

Alarms: 37-way D-type plug

ALARM OUTPUTS

Prompt:	Isolated changeover relay contacts
Service:	Isolated changeover relay contacts
System:	Isolated changeover relay contacts

Alarm contact rating 1A @ 50VDC (Resistive) 50VA

EXTERNAL STATUS INPUTS

5 external status inputs are provided:

Characteristics:

General purpose inputs

Active:	-60VDC < input voltage < 0.8VDC (Generally 0V)
Inactive:	1VDC < input voltage < 5VDC or open circuit

The external equipment must be capable of sinking 0.25mA when applying 0V, and 63mA when applying -60VDC.

EXTERNAL CONTROL RELAYS

Four relays are available for the control of external equipment. These provide isolated changeover contacts:

Contact rating: 0.4A @ 125VAC
 2A @ 30VDC

External Ringing Supply:

Frequency 17-50Hz
Ringing Voltage 50-150VAC RMS with station DC supply offset (-48V)
Ringer Start O/P Open collector WRT - station supply (-48V)
 Max current = 50mA

Note: Any external ringing supply connected to the equipment must conform to BS6301.

Local Port:

V.24, RS-232 (9-pin D-type connector)
(No handshaking)

Network Port:

Four V.28 inputs (9-pin D-type connector)
Four V.28 outputs

Gain

The gain through the system to or from the channel interface backplane connector for a channel containing a voice encoded signal is fixed at 1. Refer to the relevant VF channel card manual for gain contributions attributable to the channel card.

Quantisation Distortion

The quantisation distortion through the system to or from the channel interface backplane connector for a channel containing a voice encoded signal is 0 qdu. Refer to the relevant VF channel card manual for the quantisation distortion attributable to the channel card.

Environmental:

Storage temperature: -20⁰C to +50⁰C
Operational temperature: 0⁰C to +50⁰C
Humidity: 5 to 95% non condensing

Delay

The delay through the system may be calculated from the following diagram:

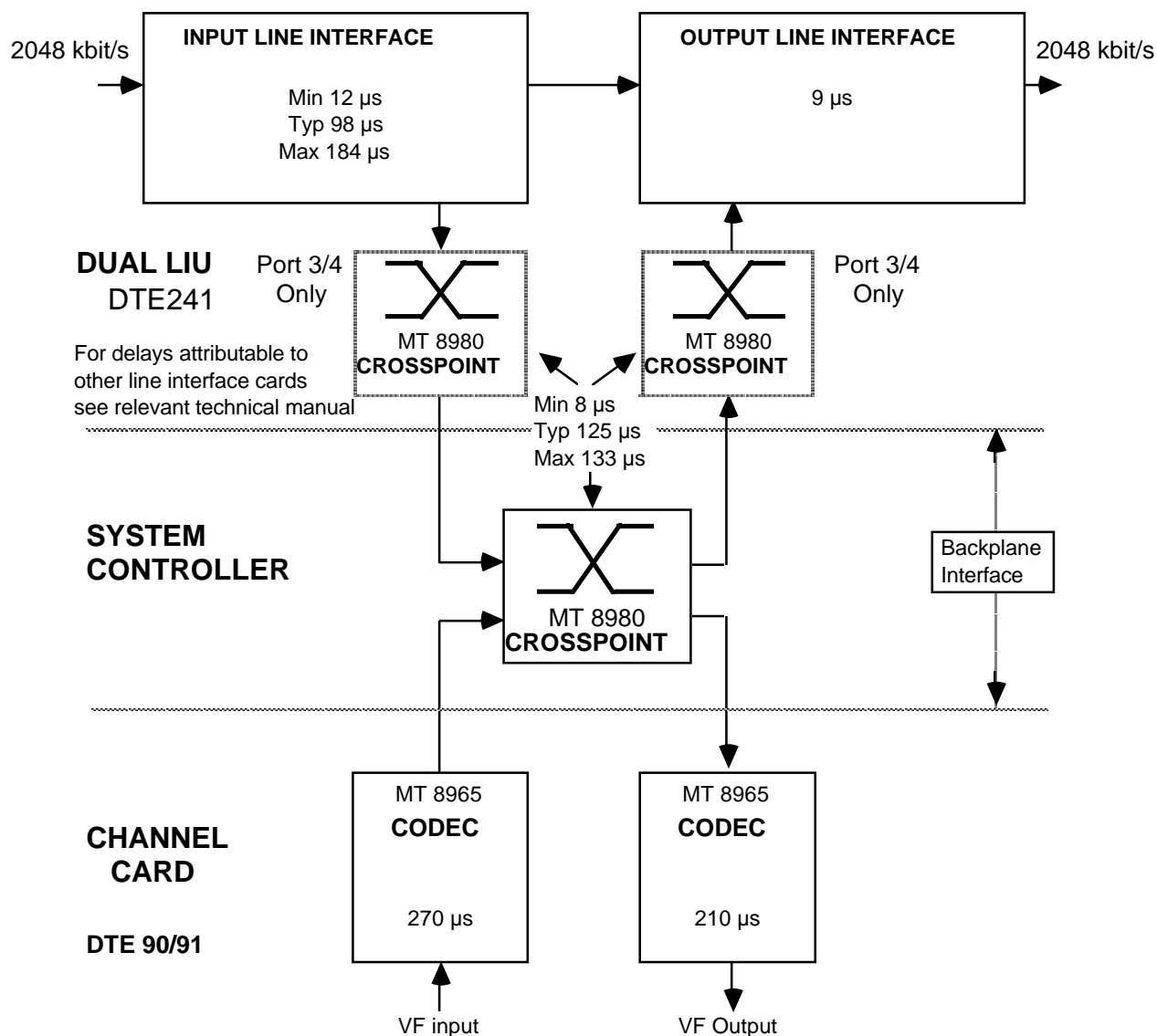

Channel card shown is for example only. Refer to the relevant channel interface card manual for delays attributable to other VF cards and data interfaces.

Mechanical	3400	3800	3900
Weight:	18kg	16kg	12kg
(fully loaded)			
Height (mm):	266	400	176
Width (mm):	485	440	440

Depth (mm): 385 253 253

2 Installation and Commissioning

2.1 General

Installation and commissioning of the equipment consists of carrying out all necessary work prior to configuration for network transmission requirements. Follow Section 2.2 for wiring connections and Section 2.3 for Link and Switch settings noting in particular the battery link (Section 2.3.1). The equipment should not be operated with the battery disconnected as this will cause unexpected results. Check the Dual LIU link settings (Section 3.1.6). Do not switch on until all cabling is in place, in particular the earthing, and all links are correctly set.

Control Terminal Operation

A control terminal will be required for initially setting up the multiplexer.

The multiplexers are controlled by the local control port, an RS-232 serial interface on the front of the system controller, the range of baud rates and parity for which are detailed in Table 2-5. The interface caters for XON/XOFF protocol.

Remote operation of the multiplexer is also possible and this is covered under Remote Control in Section 5.5.

On power up, if configured for local control, the multiplexer will output Self Test information messages then a prompt and wait for the user input line. User input is not case conscious.

Input lines are terminated by carriage return <CR> and no actions will be taken until CR or other special characters have been entered. Lines may be aborted before CR is entered by entering <ESC> or !. All lines will be acknowledged by the multiplexer by returning at least a prompt character which will indicate the result of the previous input and that the multiplexer is ready to accept another line.

All multiplexer commands are based on a menu selection scheme. The menu structure is in the form of a tree with a single 'root' menu which branches to various 'sub-trees' and eventually to 'leaves' which are individual commands.

Selection of the route through this tree from the current menu is by entering selection characters as defined in each menu along the way. These selection characters may be entered singly resulting in prompts at each menu level, or as a complete string. Most commands will also require parameters, some will require multiple lines of parameters which can either be appended to the selection characters or in following input lines in which case the unit will prompt for them as required.

2.1.1 Modes of Operation

The multiplexer local control system can operate in four modes, 'Brief' or 'Verbose' and 'Echo' or 'No Echo'. On initial power up the operating mode will default to the 'Verbose' + 'Echo' mode. which can be changed by menu commands if required. Verbose mode *must* be used with the NCS.

Brief/Verbose

In verbose mode the local control port will provide full prompts for menu selection and parameter entry, the output from commands which display information will also contain some explanatory text. In brief mode, all menu and parameter prompt texts are suppressed and output information will have any explanatory text suppressed. Brief mode is provided for factory test purposes, or fast access by experienced users using pre-prepared configuration scripts controlling a communication package running on a Personal Computer for example.

Echo/No Echo

If echo is enabled, all normal characters received will be echoed. Lower case characters entered will be echoed in upper case.

2.1.2 Commands and Control Characters

Prompt Characters

The multiplexer will always prompt when it requires another input line, in verbose mode this will consist of text indicating possible selections of parameters required followed by a special prompt character. In brief

mode only the prompt character will be displayed. There are three possible prompt characters as shown below:

- > This is the normal prompt when more input is required
- *> This prompt is given after a command has successfully been completed
- ?> This prompt is given after an invalid input line which may be due to an invalid menu selection, or an invalid parameter for a particular command, in this case an error message would have already been output in brief and verbose modes.

2.1.3 Special Input Control Characters

The following input characters have special meanings:

- Esc Aborts the current input. If entering parameters, the current command is aborted, if selecting from a menu the current menu is aborted and its parent menu becomes the current menu. ESC will always insert a CRLF and the multiplexer will prompt for another input line.
- ! This character is primarily intended for computer control of the unit, its function is similar to ESC but the root menu becomes the current menu. If echo is enabled, the character is echoed.
- Ctrl+S <XOFF> Instructs the unit to cease serial data transmission
- Ctrl+Q <XON> Instructs the unit to re-commence serial data transmission
- Ctrl+X Used as a means of escape from the control of a remote unit. Sending Ctrl+X from the console will cause the unit to transmit XOFF to the remote unit and return control to the local unit.

All other characters, including Ctrl+W, are considered to be menu selections or parameters, all lower case input will be forced, and if enabled, echoed in upper case.

2.1.4 General Conventions for Verbose Prompts and Messages

In verbose mode the multiplexer provides useful prompting information for menu selection and parameter entry, these prompts follow some general conventions.

Where possible all prompts will be on a single 80 character line ending with one of the special prompt characters. If used with a terminal, input from the user will be echoed following the prompt on the same line.

For menu selection the prompt will consist of a list of options separated by the '|' character.

The options will be displayed in lower case with the character required to make the selection in upper case, where possible it will be the first character of the option name.

2.2 Installation

This equipment must only be installed by suitably qualified Service personnel. Please ensure you read the statutory notices in the preface of this manual before proceeding.

2.2.1 Unpacking

Check for any physical damage on receipt of the equipment and advise Cray Communications by contacting our Customer Service Department and the carrier immediately if any damage is found. Retain the packing material in case future transportation is required.

2.2.2 Mounting

The unit should be mounted in a standard 19" rack or in a suitable compatible equipment housing. Side supports should be fitted to each side of the rack to aid mounting and to prevent undue strain on the front angle brackets. Sufficient clearance should be allowed to give adequate ventilation. A means of preventing flaming material reaching the floor in the event of fire should be provided underneath the multiplexer chassis.

CAUTION:

It is advisable to remove all channel cards before inserting or removing the chassis from a rack. Incorrect handling of a fully equipped chassis could result in undue strain on the chassis tie bars. Observe electrostatic DC Connections to the terminal block on the power input panel are as follows:-

2.2.3 Power Connections and Earth Bonding

Connection of the Power Supply

This apparatus may only be used with internally fitted power supply units as follows:

i) 3400 and 3800 units

DT162	48VDC Input	38-60 VDC @ 400 watts
DT163	115VAC Input	99-132 VAC, 47-63 Hz @ 200 watts
DT163	240VAC input	187-264 VAC, 47-63 Hz @ 200 watts
DT164	24VDC Input	18-32VDC @ 200 watts

ii) 3900 Units

DT165	240VAC Input or 115VAC Input	187-264 VAC, 47-63Hz @ 100 watts 99-132 VAC, 47-63Hz @ 100 watts
DT168	48VDC Input	38-60 VDC @ 200 watts
DT169	24VDC Input	18-32 VDC @ 100 watts

For the ac powered versions, an auxiliary input of 38-60VDC @ 100 watts may be required depending on the interface cards fitted.

Other usage will invalidate any approval given to this apparatus if as a result it ceases to comply with the edition of BS6301 to which it was approved.

The power supply units comply with BS6301:1989.

The primary DC Power source for the equipment must be from a supply complying to BS6301.

The power units generate the following DC voltage and current outputs.

	+5V	-5V	+12V	-12V
DT162	20A	1.0A	3.0A	3.0A
DT163	20A	1.0A	3.0A	3.0A
DT164	20A	1.0A	3.0A	3.0A
DT165	8.0A	0.5A	1.0A	1.0A
DT168	8.0A	0.5A	1.0A	1.0A
DT169	8.0A	0.5A	1.0A	1.0A

48VDC versions

RR	External Ringing Voltage Return.
RV	External Ringing Voltage Supply.

-48VB	DC Supply to PSU B . Not fitted on the 3900.
-48VA	DC Supply to PSU A (Supplies backplane only on the 3900)
0V	DC Return
EC	External Common Signal connection for use with some channel cards.

24VDC versions 3400 and 3800 only

RR	External Ringing Voltage Return.
RV	External Ringing Voltage Supply.
+24V A	} 24VDC supply to PSU A.
-24V A	} " " " " " "
+24V B	} 24VDC supply to PSU B.
-24V B	} " " " " " "
EC	External Common Signal for use with some channel cards on the 3400 only.

There is no backplane feed for these 24VDC systems, so 2-wire Loop Disconnect subscriber cards and Ringing Generators can not be used.

Connections on the 3400 power input panel do not have the ringing voltage connections, these are provided on a separate terminal block on the rear of the chassis. See Section 2.2.9

AC Mains versions

AC Connection is provided by an IEC 320 type plug.

Power I/P connections to the 3900 are made directly to the PSU front panel which also incorporates an on/off switch.

Note: The AC versions do not provide -48VDC from the internal AC power supply unit. Channel cards which require a -48VDC supply must have a separate -48VDC supply connected to the -48VDC I/P on the power I/P panel.

Fuses: The power input panel contains a fuse which protects the -48VDC feed to the channel cards. The PSUs contain their own protective fuses. Refer to the equipment labelling for fuse ratings.

Earth Bonding

Correct earth bonding of the chassis is important if the equipment is not to be affected by electrostatic discharge (ESD) or other environmental interference sources. A separate earth connection must be made from the

chassis earth stud to the station earthing system. The resistance of this connection must not exceed 0.03 ohms which should be checked using an earth bonding tester. Note that if the earthing arrangements are via a rack earth bar or rack framework, the total earth resistance must not exceed that stated above.

2.2.4 Alarm and Control Wiring

The alarm outputs, control outputs and external status inputs are accessed via a 37-way D-type connector. The alarm and control output change over contacts are isolated. The N/C and COM contacts should be used to provide a short circuit loop during alarm conditions. See Table 2-1.

An alarm is active when the relays are de-energised, hence when power is removed from the unit all alarms become active.

The external status inputs are '0V sensing' and designed to operate with TTL level inputs. 0V is the alarm condition with +5V or open circuit being the non alarm state. See alarm specifications in Chapter 1.

External status lines 2 to 6 may be connected to co-located equipment to monitor, for example, alarm relay status. The external relay contacts may be wired to control external equipment.

Only equipment with SELV connections may be connected to the alarm and control interfaces.

37-way D-type Plug Pin No.	Function
1,6,7,20,24,25	0V Connections
2	External status 2
21	External status 3
3	External status 4
22	External status 5
4	External status 6
23	PSU A Fail
5	PSU B Fail
8	COM }
26	N/O } System Alarm Relay
27	N/C }
28	COM }
9	N/O } Service Alarm Relay
10	N/C }
11	COM }
29	N/O } Prompt Alarm Relay
30	N/C }
31	COM }
12	N/O } Receive Attention
13	N/C } Relay
14	COM }
32	N/O } External Relay 1
33	N/C }
34	COM }
15	N/O } External Relay 2
16	N/C }
17	COM }
35	N/O } External Relay 3
36	N/C }
37	COM }
18	N/O } External Relay 4
10	N/C }

Normally Closed (N/C) is the de-energised state.

Table 2-1 Alarm Connector Pin Connections

2.2.5 PCM and G.703 Clock Connections

The Dual LIU utilises either the DT315 or DT316 I/O adapter for interfacing to 75 or 120 ohm lines respectively. These plug into the I/O connectors shown in the chassis front and rear views in section 1.

The DT315 has 75 ohm BNC unbalanced connectors, with the 'screen' of the transmit connector earthed by mechanically securing it to the body of the I/O adapter. The 'screen' of the receive connector is isolated from the body of the I/O adapter with insulating washers.

If it is required to earth the 'screen' of the receive connector instead of the transmit, then it will be necessary to re-assemble the I/O adapter with the insulating washers fitted to the transmit connector.

The DT316 has PCM connections using two 9-way D-type connectors. The transmit O/P signal is present on pins 5 and 9, and the receive I/P signal is on pins 1 and 6. The cable screen should be connected to the body of the connector.

The clock signals are presented on a separate 9-way D-type connector with the transmit clock on pins 4 and 8, and the receive clock on pins 2 and 7. The cable screen should be connected to the body of the connector.

The Dual LIU I/O adapters are equipped with bypass relays that will, on power down or under firmware control, bypass PCM line 1 to line 2, and Clock in to Clock out. This action may be inhibited for the PCM signals only by fitting links LK1-LK4 on the I/O adapter to positions 2-3.

2.2.6 Data Wiring

The connectors on the chassis allow for data connection to channel cards. Data connectors must be inserted to the corresponding connector for the channel card positions. i.e. a channel card in P3A must have its data connector inserted in to the corresponding connector marked P3A on the I/O panel of the unit. The connector type is a 96-way DIN 41612 Type C plug (Male).

The pin allocations for channel cards vary from card to card. A detailed pin out can be found in the relevant channel card manual.

A universal I/O adapter DT280 is available to convert the 96-way DIN 41612 Type C plug to a 50-way Amphenol Female Connector. This adapter provides additional screening and must be used where compliance to EMC specifications are required. The pin connections are shown in the relevant channel card manual.

2.2.7 Network Management Connections

Network management is connected to the unit via a 9-way D-type socket. This port uses V.28 signal levels. The COM signals on the port are defined by the System Controller Patchfield. Note: It is possible to re-direct the local port VDU access via the Network Port using these Patchfields

Pin No.	Function	
1	COMo1	
2	COMo2	OUTPUTS
3	COMo3	
4	COMo4	
5	COMi1	
6	COMi2	INPUTS
7	COMi3	
8	COMi4	
9	0V	SIGNAL GROUND

Table 2-2 Network Port Pin Connections

2.2.8 Local Port Connections

Local port (DCE) access is provided via a 9-way D-type socket situated on the front of the system controller PCB. Access can be gained to this connector via a covered cut out in the front panel.

Pin No.	Function
1	NC
2	Transmit Data (INPUT)
3	Receive Data (OUTPUT)
4	Control (DTR)
5	0V
6	NC
7	Control (RTS)
8	NC
9	NC

Table 2-3 Local Port Pin Connections

The control outputs are permanently wired to the 'ON' condition.

Warning: Care should be exercised to ensure that the terminal being connected to the multiplexer local port shares a common earth with the multiplexer, otherwise permanent damage may result.

2.2.9 Ringing Voltage Connections

When using a 2-wire subscriber interface, e.g. DTE64, a ringing voltage is required by the card to ring the telephone.

The ringing voltage may be supplied by a ringing generator card DT579 or an external supply via a terminal block on the power input panel of the 3800 and 3900 or in the case of the 3400 on the rear of the equipment. The 3400 has the option of fitting a 35 Watt ringer in the rear of the chassis by replacing the centre blank panel with a ringer DT186, this ringer is supplied with plug connectors which must be connected to the backplane before it is secured in position. If an internal ringer is used either DT579 or DT186 it will require a -48VDC supply via the switch (not on 3900) and fuse on the power input panel. This supply is required even with a mains powered chassis.

The DT579 ringing generator card supplies ringing voltage for up to ten telephones of REN = 1. DT579 ringing generators cannot be paralleled to increase output drive therefore the 3400 and 3800 backplane is split into 4 sections to allow more than one ringer to be fitted if required, e.g. chassis equipped with more than 3 subscriber cards. Links must be positioned correctly to isolate the sections otherwise damage to the ringing generators will result. In order to select which supply is used, links are positioned on the backplane to select the supply for each section, hence up to four internal ringing generators may be fitted (DT579) supplying each individual section. The links are listed in Table 2-4.

Any external ringing supply must be battery backed. The ringer supply terminal block is labelled below:

RV - ringing voltage

RR - ringing return (common to all sections)

The ringing supply is across RV and RR. The RR terminal must be connected to the station battery 0V.

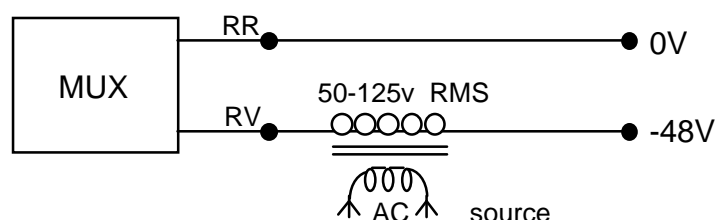

The 3400 has an additional terminal RS (Ringer Start) on the ringing supply terminal block, this is used to indicate when ringing voltage is

required. It is an open collector O/P. When RS=0V (battery +ve) then ringing voltage should be present across RV and RR.

The RS terminal does not have to be connected and is provided for external ringers that require a start signal. Ringing voltage may be present continuously across the RV and RR terminals.

Section	3800 Links	3400 Links
PORT 1 - 3C	LK1	LK3
PORT 3D - PORT 3F	LK2	LK2
PORT 4A - PORT 4C	LK3	LK1
PORT 4D - PORT 4E	-	-

Table 2-4 Backplane Links

The section of the backplane, port 4D to port 4E is always connected to the terminal block, if an internal ringer is used no connection should be made to the terminal block of the equipment. The cover on the terminal block must be fitted when an internal ringer is fitted as ringing voltage will be present across the terminals. Note also that ringing voltage will be present on Pin 25a of the DIN 41612 I/O connector for each port.

The backplane sections are as shown in Figure 2-1.

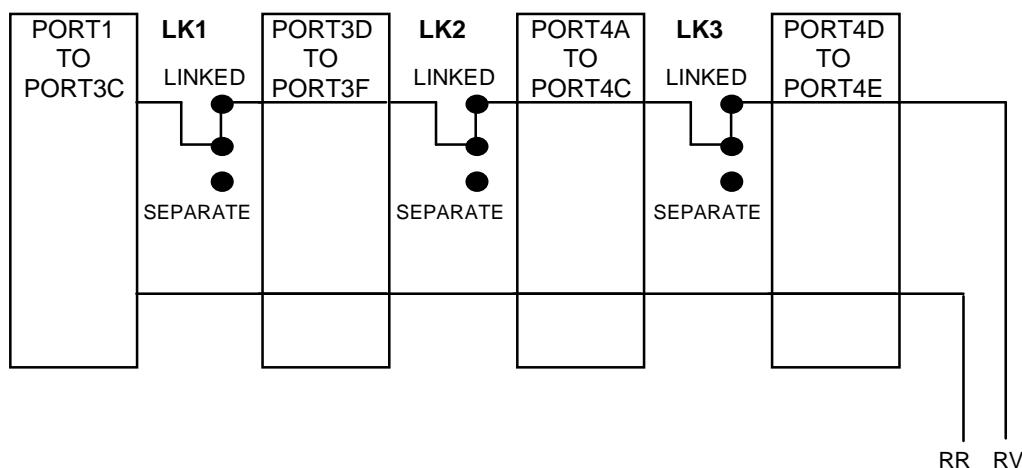

Figure 2-1 Backplane Ringer Sections

Common 'E'-wire Connection

When using a 24 channel E&M signalling card (DTE062) an external 'E'-wire common may be required. This common 'E'-wire should be connected to terminal EC on the power input panel.

2.3 Commissioning

2.3.1 Link and Switch Settings

The multiplexer may be controlled via its local port, a DCE V.24 RS-232 serial interface. This port must be configured by switch SW1 on the system control card DTE221. Switch SW1 is read at power up and periodically to allow configuration of the local port to be modified once powered up. Switches S2 to S8 of SW1 control the set up of the local port. Options available are shown in Table 2-5.

Switch S1 of SW1 allows the operator to communicate locally with a unit when it is normally operating as a remote unit in Local/Remote mode.

The links on the System Controller should be in the following positions:

LK1 2-3

LK2 2-3

LK3 2-3

LK4 2-3

LK5 1-2

LK6 1-2

LK7 1-2 RAM backup battery connected. (2-3 = disconnected) *

LK8 2-3

* **Note:** The unit should *not* be operated with the battery disconnected.

Switch	Closed	Open	Function
1	Normal	Local	Local Access
2	1 bit	2 bits	Stop bits
3	7 bits	8 bits	Data bits
4	Even	Odd	Parity
5	}		
6	} Local Port	Baud Rate	(See Table 2-6)
7	}		
8	Enable	Disable	Parity

Table 2-5 System Controller SW1 Switch Settings

Rate	S5	S6	S7
150	Closed	Closed	Closed
300	Open	Closed	Closed
600	Closed	Open	Closed
1200	Open	Open	Closed
2400	Closed	Closed	Open
4800	Open	Closed	Open
9600	Closed	Open	Open
19200	Open	Open	Open

Table 2-6 Local Port Baud Rate Switch Settings

2.3.2 Switch on Procedures

Connect a VDU, set so as to be compatible with the settings made on SW1, to the local port. Switch on the multiplexer. On initial power up, the multiplexer will automatically enter self test mode.

Self Test Mode

The unit incorporates a self test facility which is activated either at power up or from menu selection and runs for a period of 8 seconds. The test will set the following conditions:

- a) Illuminate all LEDs on the on-line system controller.
- b) Set all alarm relays except the System relay.
- c) Run a self test configuration.
- d) Each LIU fitted will have its relays set to bypass and PCM looped.
- e) Sync source will be derived from the free running VCO clock.

On completion the VDU should display 'self test passed' if not it will indicate failure and list the failed items. The self test will fail if Dual LIU I/O adapters are not fitted.

2.3.3 Initial Multiplexer Set-up

Install the Dual LIU and channel interface cards in the required port slots and connect a terminal to the local port and obtain the Root Menu prompt as follows:

```
(P63) Maint | Fault | mOde | Configure | Time | Remote | Smart | closE >
```

After switching on a new unit or one that is unconfigured, it will be necessary to set certain parameters using a dumb terminal. Carry out the 'Install' procedure under the 'mOde' menu option (see Section 5.3.4) ensuring that networking is enabled. If required networking can be disabled for Local/Remote operation after the changes have been saved. In addition carry out the following:

- 1) Set the real time clock. (See Section 5.2.2.)
- 2) Set the calendar. (See Section 5.2.2.)
- 3) Remove all timed events. (See Section 5.2.3.)
- 4) Disable alarm events. (See Section 5.4.1.)
- 5) Install cards into the Equipment Map. (See Section 5.4.18.)
- 6) Load the default PCM configuration and save into all 14 configurations. (See Section 5.4.2.)
- 7) Check the active fault log and diagnose and clear any remaining non PCM configuration faults.

2.3.4 Alarm Indicators

The multiplexer has 9 LEDs which are situated on the front of the system controller PCB. The LEDs indicate any alarm conditions that occur on the unit. The main functions are listed below with a detailed function for each LED contained in the fault chart in Section 6.1.1.

Misc Alarm

Port 1 Alarm

Port 2 Alarm

Port 3 Alarm

Port 4 Alarm

Not Primary Sync

PSU fault

System Alarm

Power

All the LEDs are red except for the Power LED. In addition to these alarms, channel cards have LEDs to indicate alarm conditions, however these can only be viewed by removing the front panel.

See Section 3.1.7 for a description of the LED indicators on the Dual LIU.

Alarm conditions can be examined via the local port or network port where an exact description of the fault can be found.

When an alarm occurs the appropriate alarm relay will also be set (See Tables in Section 6.1.1).

3

Dual Line Interface Unit

3.1 General

Dual Line Interface Units (DTE241) installed in ports 1 and 2 must be fitted with DT986/2 or later firmware. When fitted in ports 1 and 2, the configuration of the DLIU is transparent to the user.

The Dual LIU will be listed as a DT310 (base card) in the Equipment map.

The Dual LIU provides an interface to two 2048kbit/s PCM streams. The PCM electrical signals comply to CCITT recommendation G.703 as either unbalanced 75 ohms or balanced 120 ohms interfaces. The options of 75 ohms or 120 ohms operation is provided by a choice of I/O adapter (DT315 and DT316 respectively) which is used in exclusively with the DT310 card. No other 3000 Series I/O adapter must be used as this may result in damage to the DT310. The Dual LIU also provides an interface to a 2048kHz clock signal, the electrical characteristics of this also comply with CCITT G.703.

When fitted in ports 3 or 4 the Dual LIU operates as a 'Smart' card which is covered separately in the operation manual X723-303051 for the Dual Line Interface Unit and not in this manual.

3.1.1 TS0 Not Frame Word Routing

Dual LIU cards fitted with firmware DT986/6 or later have the facility to connect the TS0 'Not Frame alignment Word' to the cross-connect switch for routing through the system or to the management patchfield. The following modes of operation are provided, and these are selectable when configuring the mode of operation for the card in ports 1 and 2.

Modes 2, 3, 4, 6 and 7 of this option require the installation of management patchfield DT995/E in the Dual LIU to gain access to the Remote Alarm bit 3.

Not Frame Words which are dropped/inserted to port (P1, P2, P3, P4) streams timeslots 0 and 1 may be cross connected to any other timeslots using the normal cross connect facilities of the multiplexer.

Mode 1 (Default)	The incoming NFW from the relevant line is written to the relevant patchfield with the Remote Alarm bit set to a 1. The outgoing NFW is read from the patchfield and the Remote Alarm bit will be set to a 0. This allows the use of patchfield 995/D
Mode 2	This is the same as mode 1 except that the Remote Alarm bit is not masked and all bits may be used by the patchfield to give TS0 transparency.
Mode 3	Line 1 - TS0 outgoing will be read from port X TS0. TS0 incoming will be written port X TS0 Line 2 - will be set as mode 2
Mode 4	Line 1 - will be set as mode 2 Line 2 - TS0 outgoing will be read from port X TS0 . TS0 incoming will be written to port X TS0
Mode 5	Line 1 - TS0 outgoing will be read from port X TS0. TS0 incoming will be written to port X TS0. Line 2 - TS0 outgoing will be read from port X TS1. TS0 incoming will be written to port X TS1
Mode 6	Line 1 - TS0 outgoing will be read from port X TS0. TS0 incoming will be written to port X TS0 Line 2 - will be set as mode 2
Mode 7	Line 1 - will be set as mode 2 Line 2 - TS0 outgoing will be read from port X TS0 . TS0 incoming will be written to port X TS0
Mode 8	Line 1 - TS0 outgoing will be read from port X TS0. TS0 incoming will be written to port X TS0. Line 2 - TS0 outgoing will be read from port X TS1. TS0 incoming will be written to port X TS1

X = P1, P2, P3 or P4

Notes:

- 1. In modes 3 to 8, the outgoing TS0 Frame bit 2 is masked to a 1.**
- 2. In modes 3 to 8, the outgoing Remote Alarm bit consists of port X TS0 Remote Alarm bit logically 'OR'ed with the Remote Alarm bit derived from the state of the incoming line signal.**
- 3. In modes 3 to 8, the incoming TS0 NFW read from the line signal and written to the port timeslot will not be masked or added to.**

4. In modes 6 to 8, bit 1 (International signalling bit) is forced to a 1 on the outgoing line signal for use with DT585.

The following options will be presented whilst configuring each mode of operation for the Dual LIU to enable the TS0 routing options to be selected. The preceding display will depend upon the LIU mode selected.

- 1 Normal
 - 2 Normal plus Remote Alarm
 - 3 L1 to TS0
 - 4 L2 to TS0
 - 5 L1 to TS0, L2 to TS1
 - 6 L1 to TS0 (DT585)
 - 7 L2 to TS0 (DT585)
 - 8 L1 to TS0 (DT585) , L2 to TS1 (DT585)
- TS0 mode 1 >

3.1.2 Clock Recovery and Selection

A recovered 2048kHz clock is available from each of the received PCM lines and a 2048kHz external clock input signal is provided. Any of these clock sources may be selected by the system controller as the system clock. These clocks are monitored by the system controller only if they are allocated in the clock priority list.

3.1.3 Jitter Attenuation

Jitter attenuators are used on the PCM and clock inputs to reduce jitter on the recovered signals. This improves jitter transfer of the system if the clock is selected as the system timing source. A two frame input buffer is provided on each PCM line input.

3.1.4 Frame Structure

The framing structure complies with CCITT G.704 and the card supports Channel Associated Signalling (CAS) or can be used in 31 timeslot mode transparent to Common Channel Signalling (CCS). The signalling mode for each of the two PCM interfaces may be selected independently.

3.1.5 G.703 Clock Output

The timing for the G.703 clock output is sourced from the system clock (PLL) except under bypass conditions when it is sourced from the G.703 clock input.

The G.703 clock output can be configured to be enabled or disabled when the multiplexer is free running.

3.1.6 Link Settings

All links on the Dual LIU are for factory use only and must be fitted in the following positions:-

TL1 and TL2	1 - 2
TL3 must be fitted	
LK1 - LK11	1 - 2
LK12	2 - 3 (middle)

3.1.7 Switch Settings

DIL Switch S1 is not used when the card is fitted in port 1 or port 2 and all switches should be set to the 'Closed' position. S1 is used when the card is fitted in ports 3 and 4 for management routing and is described in the Operation manual for the Smart Dual LIU card.

3.1.8 LED Indicators

The LED Indicators have the following function:

	Yellow	o	Remote Multiframe Alarm Received
Line 2	Yellow	o	Remote Frame Alarm Received (Bit 3 in TS0)
	Red	o	Miscellaneous
	Yellow	o	Remote Multiframe Alarm Received
Line 1	Yellow	o	Remote Frame Alarm Received (Bit 3 in TS0)
	Red	o	Miscellaneous

The miscellaneous LED for each line will illuminate for the following reasons:

- 1) PCM Loss
- 2) AIS
- 3) Frame Sync Loss
- 4) Error Rate 10-3
- 5) Frame Slip
- 6) Multiframe Sync Loss
- 7) TS16 A.I.S
- 8) Low Error Rate
- 9) Line Output Fail
- 10) Local Loop
- 11) Incoming Loop

Both miscellaneous LEDs will illuminate for the following reasons:

- 1) System Restart
- 2) Unconfigured
- 3) Config Rx Fail (Transfer failure of data from the System Controller)
- 4) Config Tx Fail (Transfer failure of data to the System Controller)
- 5) Self Test Fail
- 6) Card in Bypass

3.2 Dual LIU Adaptors

DT315 and DT316 I/O adaptors must be used in conjunction with the Dual LIU. These include the isolation/matching transformers and bypass relays. The I/O adaptors provide the means of connection to the PCM lines and G.703 clock (See Section 2.2.5). Knurled screws are supplied with the I/O adaptors to fit them to the chassis, these must be used to ensure adequate earthing of the connector screens.

3.2.1 DT315 75 Ohm I/O Adaptor

This adaptor uses standard 75 ohm BNC sockets for connection to the two PCM lines and the G.703 clock. As standard, the screens of the output sockets are connected to earth and the screens of the input connectors are isolated from earth. (See section 2.2.5)

3.2.2 DT316 120 Ohm I/O Adaptor

This adaptor uses three 9-way D-type sockets for connection to the two PCM lines and the G.703 clock. The connections are balanced and are as follows:

PCM Connectors

PCM Out	5 and 9
PCM In	1 and 6
Ground	3

G703 Clock Connector

Clock Out	4 and 8
Clock In	2 and 7
Ground	3

Bypass

When the bypass relays are in the un-powered state, i.e. if the LIU is removed from the chassis or if bypass is enabled by software, the relay contacts will be in the bypass position. If the links on the I/O adaptor LK1, LK2, LK3 and LK4 are in position 1-2 the PCM input on line 1 will be connected to the output of line 2 and the PCM input on line 2 will be connected to the output of line 1. If LK1, LK2, LK3 and LK4 are in position 2-3 this connection between line 1 and line 2 will not be made.

In bypass mode, the G.703 clock input is always connected to the G.703 clock output.

4 Management Configuration

4.1 Introduction

The multiplexer may be controlled either locally by a terminal connected to its local RS-232 port, or by a Network Control System (NCS) connected to the V.28 network management port. Access to spare bit capacity in TS0 is provided for networking and remote control.

NCS operates a poll and response type of system. Only the node that has been polled by NCS will respond. Normally NCS traffic is carried through the network in the TS0 Not Frame word (NFW) spare bits 4, 5, 6, 7. In resilient networks, it is usually necessary to have at least 2 routes through the network to reach each node. These are referred to as the A and B polling branches. Traditionally, the A branch uses NFW bits 4 and 5, whilst B uses 6 and 7. In order to avoid the NCS seeing its own polling under loop conditions for example, the patchfield arranges for the polls to be transmitted in bits 4 and 6, whilst the responses are carried in bits 5 and 7.

The multiplexer system controller and Dual LIU are equipped with firmware patchfields. Each of these contain 8 pre-programmed patchfields, 7 of which are available for the user to select on a per configuration basis. The patchfields are selected for the 14 management configurations using the 'Install' menu. (See Section 5.3.4.)

The system controller patchfield deals with the routing of management data between the backplane management bus ('M' bus), the V.28 network ports, and the system controller management UARTS, while the LIU patchfield deals with data between PCM 'TS0' bits and the management 'M'bus.

All cards in the multiplexer are linked by a bi-directional management "Wired OR" bus. Up to 4 bits are available on the 'M' bus, termed M1 to M4, these may be accessed by the Dual LIU and/or system controller patchfields for LIU to system controller, or LIU to LIU communications. Several LIUs for example, could broadcast the polling sourced by the system controller patchfield. The response from any of the LIUs would be fed back to the system controller patchfield via a logical ANDing arrangement inside the LIU patchfields and a wired OR connection to the Mbus. It should be noted that all nodes that have not been polled return a null response which is to be output logic 1 continuously which allows all

the channels to be groomed together via the ANDing functions of the patchfield and wired OR'ed Management Bus. A block diagram of the management patching facilities are shown in Figure 4-1.

4.2 System Controller Patchfield

The patchfield on the system controller routes management data between the backplane management bus, the V.28 inputs and outputs on the network port and the three UARTs used for system controller access to the management data. There are up to seven patchfields from which one may be selected. The default patchfield number is stored in an E²PROM which also contains the default patchfield numbers for the Dual LIU patchfields when in port 1 or 2.

UART A and UART B are used for network management or when operating as a remote unit, while UART C is used for the local RS232 port.

Table 4-1 shows the patchfields that have been pre-programmed into the system controller management firmware DT990C.

The standard patchfields on the system controller use COM1 V.28 I/O port, the M1 bus line and UART A for management branch A, and COM3 V.28 I/O port, the M3 bus line and UART B for management branch B.

4.3 Dual LIU Patchfields

The patchfield on the Dual LIU is divided into two halves. Each half provides the communication of management data between the TS0 non-frame word of one of the PCM lines and the M busses. Each half of the patchfield may have one of seven pre-programmed patchfields selected independently.

Table 4-2 shows the patchfields that have been pre-programmed into the dual LIU management firmware DT995D. The electrical equivalent diagrams can be found in Appendix A. If access to the Remote Alarm bit 3 is required within the patchfield, then the Dual LIU must be fitted with patchfield DT995E. Contact Case Communications for details of this patchfield.

Line 1 on the Dual LIU uses management bus lines M1 & M2 for communication with the system controller or other LIUs. Line 2 uses management bus lines M3 and M4. In the non-frame word of TS0, bits 4 and 5 are used for branch A poll and response respectively, bits 6 and 7 are used for branch B. Patchfield 1 should be selected for unused PCM lines.

4.3.1 Cross-connect Bits

On the Dual LIU it may be necessary for polls and responses on one PCM line to be transferred to the other PCM line as well as being routed to the management bus. To enable this to happen the patchfields have internal registers which are used to store data from one half of the patchfield so that it can be input to the other half. In this way 2 bits of data can be transferred from one PCM line to the other in each direction. These signals are termed X1, X2 for line 1 and X3, X4 for line 2.

4.4 Examples of Management Patchfields

Some examples of possible network management patchfield selections are described and relate to Figure 4-2 and patchfields 990C and 995D.

EXAMPLE 1 - SOURCE POLLING

This configuration uses system controller patchfield 2 and dual LIU patchfield 2.

This configuration would be used where the multiplexer is used as the 'master' on a network. The 'master' is the node to which NCS is physically connected to in order to gain access to the network. Branch A of the NCS would be connected to COM1 on the network port and branch B would be connected to COM3. The poll from branch A will be routed to the M1 bus line, via the patchfield on the system controller. The patchfield on the LIU would then route this to bit 4 on the TS0 non frame word of the PCM output on line 1.

The LIU will receive the polling response on bit 5 of the TS0 non-frame word received on line 1. which will then be routed back to the system controller via the M1 bus line and back to the NCS via COM1.

Branch B polling and responses work in a similar way using COM3, M3 and line 2 on the LIU. The system controller will transmit and receive management data via UART A and UART B

EXAMPLE 2 - RECEIVE POLLING AND TERMINATE

This configuration uses system controller patchfield 2 and dual LIU patchfield 3.

In this example the multiplexer is a 'slave' on the network and receives polls via the PCM lines. No polling is passed on, it is terminated at the nodes management UART. This should be used to prevent noise entering the network from an unterminated Network connection. The branch A polls will be received on bit 4 of the TS0 non frame word on the received PCM line 1. These will be routed via the patchfield to the M1 bus line. The patchfield on the system controller will route this to UART A for access by the system controller processor. The response from the system controller is routed from UART A by the patchfield to the M1 bus line. On the Dual LIU the data received on the M1 bus line is routed via the patchfield to bit B5 of the TS0 non-frame word on the PCM transmitted from line 1.

Branch B polling and responses work in a similar way using PCM line 2, management bus line M3 and UART B.

EXAMPLE 3 - RECEIVE POLLING AND TRANSMIT ON

This configuration uses system controller patchfield 2 and dual LIU patchfield 4.

In this example the multiplexer is a 'slave' on the network with the LIU working in a 'ring' network. In this application the polls and responses received on one PCM line need to pass through to the other and vice versa. The patchfield on the LIU routes bit 4 of the TS0 non-frame word received on line 1 to the M1 bus line and also to bit 4 of the TS0 non-frame word to be transmitted on line 2.

In this way the poll can pass through the Dual LIU on to the next node in the network. The management data routed to M1 is then routed to UART A by the patchfield on the system controller to enable management control of the multiplexer.

The response from the system controller is routed back on to the M1 bus line. On the Dual LIU, this response is combined, via the 'AND' function in the patchfield with a response received on bit 5 of the TS0 non-frame word received on PCM line 2. The combined response is output on bit 5 of the TS0 non-frame word transmitted on line 1. This response then passes back through the network to branch A of the NCS. Branch B polls and responses work in a similar way except that polls are received on line 2

and pass through in the other direction. Bus line M3 is used for communication between the Dual LIU and system controller.

EXAMPLE 4 - REMOTE CONTROL VIA TS0

The multiplexer may be operated in a local/remote mode where equipment at both ends of a point to point PCM link are controlled from one end only without any network management. Fig 4-3 shows two multiplexers connected together using Line 1.

For this configuration the system controller would use patchfield 3. The Dual LIU would use patchfield 2 if the transmitted management data is on bit 4 and received data is on bit 5 of the TS0 data. If the transmitted data is on bit 5 and received data is on bit 4 the Dual LIU will use patchfield 3.

At the local end, information will pass from the local port via UART A and the M2 line, to Line 1 on the relevant Dual LIU. Data from the remote end will pass through the Dual LIU to the system controller, via the M1 line and UART A input to the local port.

At the Remote end, the system controller will receive data from the relevant Dual LIU's line 1 via the M1 bus. This data will then be used to control the multiplexer via UART A. Return data will be sent from the system controller to the Dual LIU's output stream via the M2 line.

Parameters required for local/remote operation using UARTEA at the remote end are as follows. These parameters are set up in the 'Install' menu.

	LOCAL MUX	REMOTE MUX
System Controller Patchfield	3	3
LIU Patchfield Line 1	2	3
LIU Patchfield Line 2	1	1
Networking	Disabled	Disabled
Net 'A' Baud Rate	1200	1200
Control Port	Local	a
Local Access Switch	Closed	Closed (Normal)

Operation by remote control using UART B which must have 'b' designated as the 'Control Port' in the 'Install' options menu is similar, but uses Dual LIU Line 2, and M3 and M4.

EXAMPLE 5 - LOCAL PORT ACCESS VIA NETWORK MANAGEMENT CONNECTOR

Using patchfield 1, 2, 3 or 4 on the system controller, the multiplexer may be controlled from a terminal connected to either the local port connector on the front of the system controller or COM4 on the network management connector. Management data from the two sources are combined by the patchfield before being routed to UART C. Data output from UARTC will be routed by the patchfield to both connectors. If terminals were connected to both ports at the same time, commands entered on one terminal will be echoed back on to both.

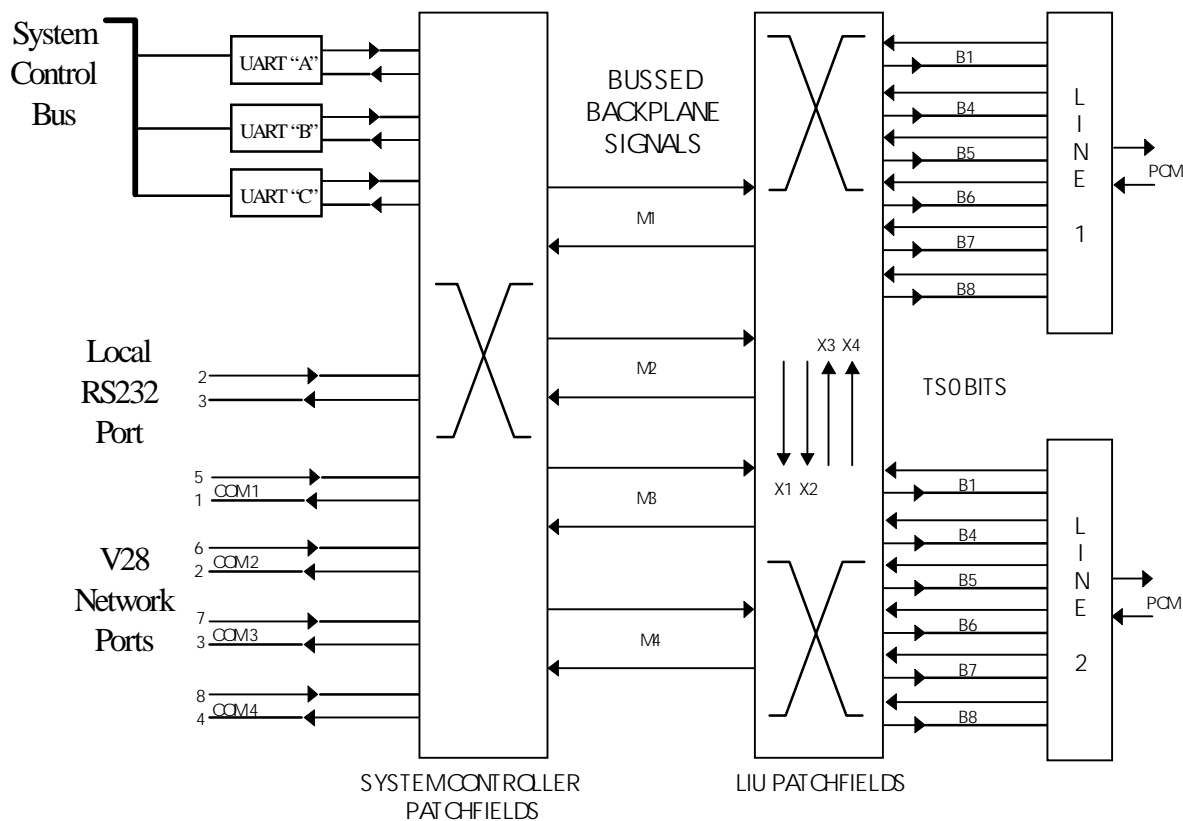

Figure 4-1 Management Patching Block Diagram

PATCH NUMBER							DESTINATION
1	2	3	4	5	6	7	
UARTC	UARTC	UARTC	UARTC	UARTC	UARTC	UARTC	RS232
RS232 COMi4	RS232 COMi4	RS232 COMi4	RS232 COMi4	RS232	RS232	RS232	UARTC
COMi1 M1	COMi1 M1	M1	M3	COMi1 COMi2	M1	COMi1 COMi2	UARTA
COMi3 M3	COMi3 M3	M3		M3	COMi1 COMi2	COMi3 COMi4	UARTB
COMi3 M1 UARTA	M1 UARTA			COMi2 COMi3 M1 UARTA	COMi2 COMi3 M3 UARTB	UARTA M1 COMi2	COMo1
				COMi1 COMi3 M1 UARTA	COMi1 COMi3 M3 UARTB	UARTA M1 COMi1	COMo2
COMi1 M3 UARTB	M3 UARTB			COMi1 COMi2	COMi1 COMi2	UARTB M3 COMi4	COMo3
UARTC	UARTC	UARTC	UARTC	M3	M1	UARTB M3 COMi3	COMo4
COMi1 UARTA	COMi1 UARTA			COMi1 COMi2	COMi4 UARTA	COMi1 COMi2	M1
		UARTA					M2
COMi3 UARTB	COMi3 UARTB			UARTB COMi4	COMi1 COMi2	COMi3 COMi4	M3
		UARTB	UARTA				M4

Table 4-1 System Controller Patchfield DT990C

Notes:

1. A space in the table above indicates a fixed '1' condition.
2. Where more than one source is shown these are logically 'ANDed' to the destination.
3. UARTA, UARTB are management serial ports.
4. UARTC, is the local serial port.
5. RS232 is the local port connector.
6. M1, M2, M3, M4 are bits on the management 'M' busses.
7. COMiX, COMoX are V.28 input and output management connections at the network port connector.

LINE 1 - PATCH							DEST
1	2	3	4	5	6	7	
			B4 M1 M2	M1 M2	M1 M2	M1 M2	X1
	B5		B7	B7	B6		X2
							X3
							X4
	B5	B4	B4 X4	B5 X4	B4 X4	X4	M1
							M2
							M3
							M4
							B1
	M1 X3 M2			M1 M2			B4
		M1 M2	M1 M2 X4		M1 M2		B5
			X3	X3			B6
					X3		B7
							B8

LINE 2 - PATCH							DEST
1	2	3	4	5	6	7	
							X1
							X2
			M3 M4 B6	M3 M4	M3 M4	M3 M4	X3
	B7		B5	B5	B4		X4
							M1
							M2
	B7	B6	B6 X2	B7 X2	B6 X2	X2	M3
							M4
							B1
			X1	X1			B4
					X1		B5
	X1 M3 M4			M3 M4			B6
		M3 M4	X2 M3 M4		M3 M4		B7
							B8

Table 4-2 Dual LIU Patchfield DT995D

Notes:

1. A space in the table above indicates a fixed '1' condition
2. Where more than one source is shown these are logically 'ANDed' to the destination.
3. X1, X2, X3, X4 are Dual LIU patchfield cross-connect bits.
4. M1, M2, M3, M4 are bits on the management 'M' busses.
5. B1, B4, B5, B6, B7, B8 are spare bits in the TS0 Non Frame Word.

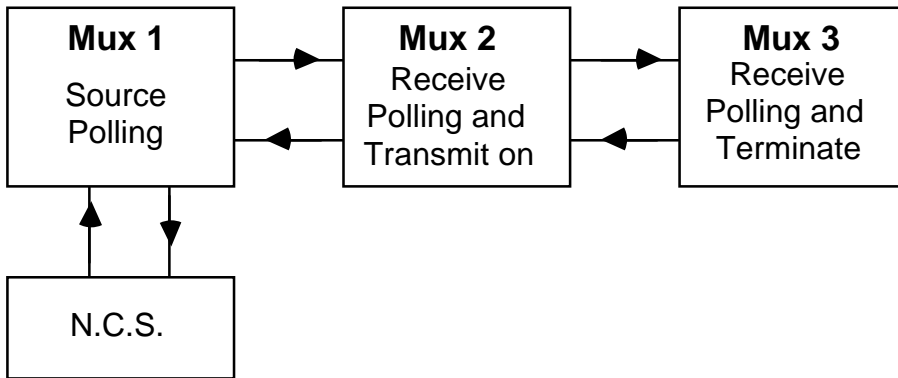

Figure 4-2 Networking Patchfield Example

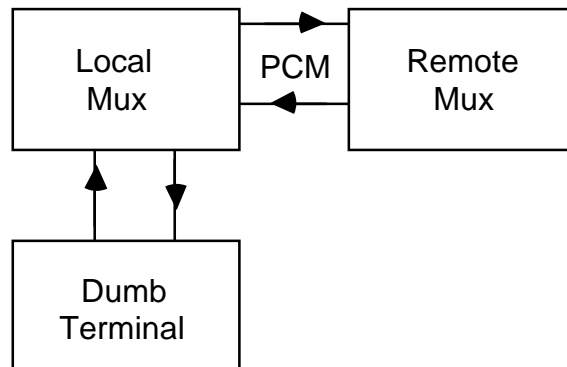

Figure 4-3 Local/Remote Patchfield Example

5

Multiplexer Configuration

5.1 Menu Tree

5.1.1 Menu Operation

Menu selections are accomplished by entering the capital/uppercase letter displayed for the required option and pressing return. The display will pass to the next associated sub menu or prompt for operator input. See Section 2.1 for a full description of control terminal operation.

The following sections provide information on the operation of the various menu commands. Note that the characters in brackets to the left of the menu, except at root level, indicate the command characters entered to reach the current point from the root menu. Where data input is required this may be entered in binary, decimal or hexadecimal with each entry having a B, D or H suffix as appropriate. If no suffix is appended 'Decimal' will be assumed.

The 'Maintenance' and 'Fault' sub menus are fully described in Chapter 6.

Menu structures for cards other than Dual LIU cards fitted in ports 1 and 2 may be found in the relevant reference manual for the card.

Root Menu

When the multiplexer is operated in secure mode, the root menu may be in one of two states:

- a) Open
- b) Closed

Closed Mode

The operator can only select the 'Open' option at this point and a prompt for a password will then be obtained.

```
() Open >O  
password >
```

The password will be entered with the echo suppressed so that the operators terminal does not show the password. Once the correct password is entered the standard root menu will be obtained.

If an incorrect password is entered then the menu will revert to the closed mode. There is no limit to the number of attempts to gain access.

() **Maint** | **Fault** | **mOde** | **C**onfigure | **T**ime | **R**emote | **S**mart | **close**E >

Open mode

If the multiplexer is operated in none secured mode (security off) a password is not required and the root menu will remain open. The display is the same with the addition of the node ID code at the left.

(P63) **Maint** | **Fault** | **mOde** | **C**onfigure | **T**ime | **R**emote | **S**mart | **close**E >

5.1.2 Root Menu

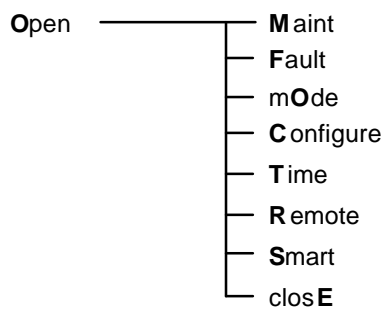

5.1.3 Time Menu

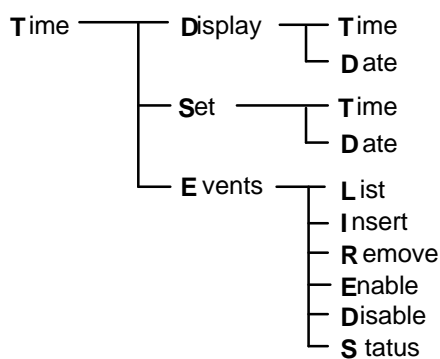

5.1.4 Mode Menu

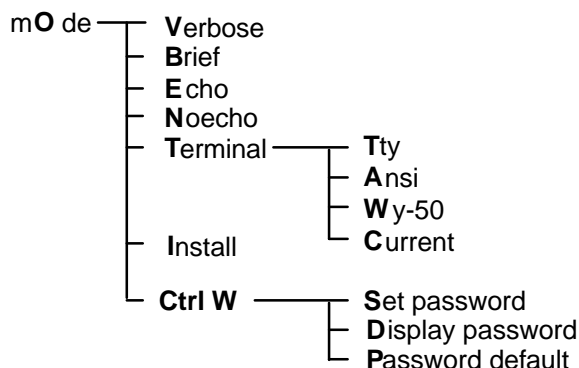

5.1.5 Configuration Menu

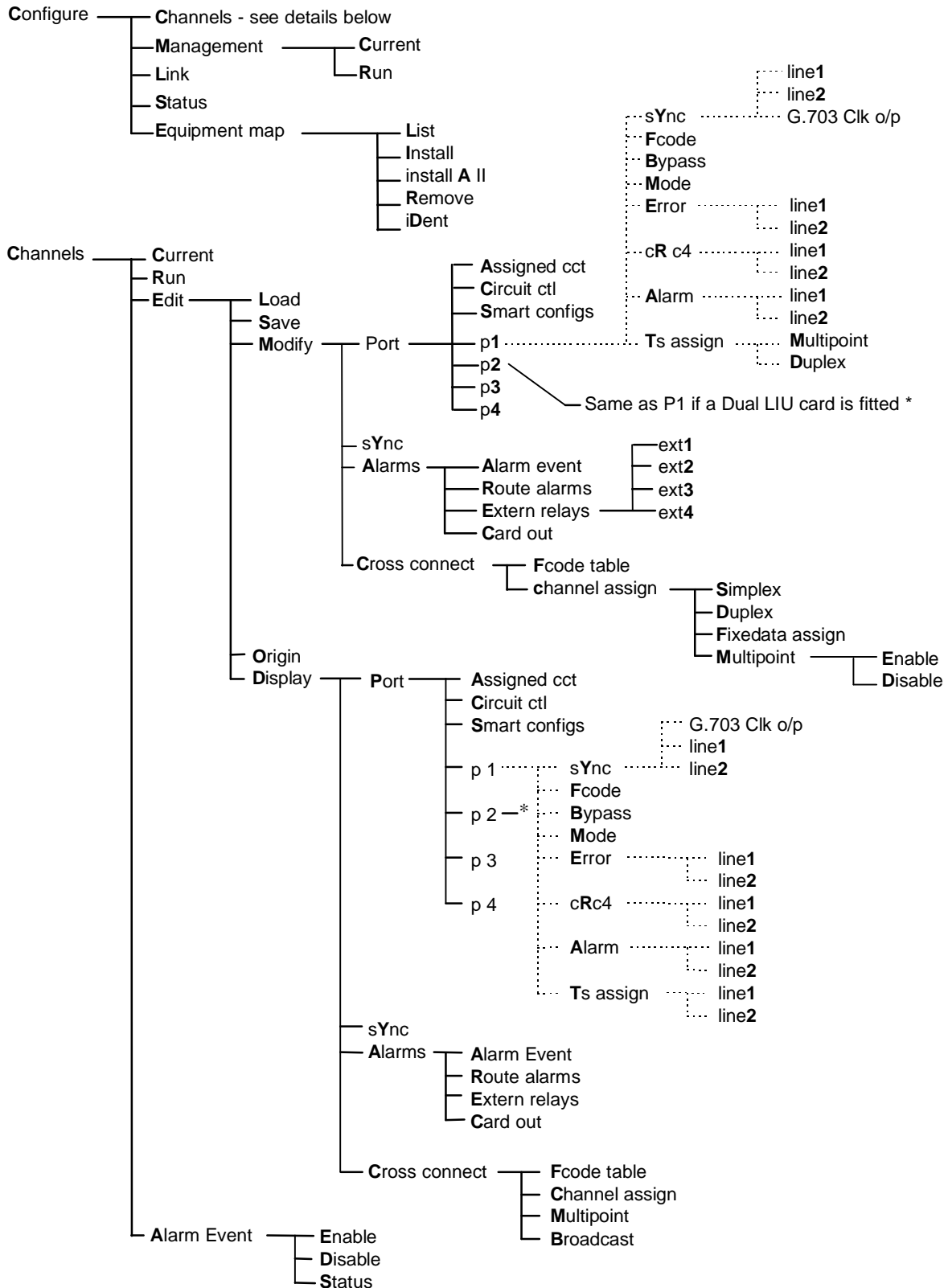

..... Only when G.703 DLIU (DTE 241) is fitted.

5.2 Time Menu

The multiplexer supports a real time clock. The time menu options provide date entry in the form: day of month, month, year. Using this together with the time data (day, hour, minute) the multiplexer is able to calculate the current week number and provide support for weekly timed event control. The number ranges are 1 to 52 for the week of the year, day 1 to 7 for the week day (Sunday normally = day 1), and standard 24 hour clock for hour, minute and second. The seconds are not required to be entered, they will be set to zero when <enter> is pressed.

5.2.1 Time and Date Setting

(T) Display | **S**et | **E**vents >**S**

(TS) Time | **D**ate >**T**

day of week, hour, minute > 4,12,8

(TS) Time | **D**ate >**D**

day of month, month, year >11,5,94

5.2.2 Time and Date Display

(T) Display | **S**et | **E**vents >**D**

(TD) Time | **D**ate >**T**

current time is week 19, Wk.day 4, hour 12, minute 8, second 43

(TD) Time | **D**ate >**D**

current date is day 11, month 5, year 94

5.2.3 Timed Events

This uses a single store for all timed events which are accessed on a week number basis. Displaying, inserting and removing events all require a week number to be specified. Week numbers range from 1 to 52 with week 0 as a special selection. Week 0 events will occur in all weeks unless specifically overwritten. If a specified week event has the same time as a week 0 event, then the specified week event has priority. When week 0 events are overwritten by editing a selected week (other than 0) they still operate in all other weeks in which they have not been modified.

The event timer will always run the last valid event prior to the current time, therefore it is necessary initially to insert an event which will run the current configuration at a time prior to the current time, for example five minutes before. This event 1 will be run immediately the events are enabled and will therefore cause no disruption to traffic.

To set up further timed events, the operator first inserts all of the regular weekly events giving 0 as the week designator.

To modify a selected week the operator inserts events specifying the selected week number and normal event data. The inserted event will then only occur within the given week number and run until the next week 0 event or another event for that week.

Note: Timed events are intended for multiplexer configuration control in a stand-alone environment. If the multiplexer is connected to an NCS then timed events will automatically be disabled, and the network controller must then be configured if real time events are required.

Creating Timed Events

```
(T) Display | Set | Events >E
(TE) List | Insert | Remove | Enable | Disable | Status >I
week 1-52 (0=all) >0
day, hour, minute, config >1,12,30,1
day, hour, minute, config >2,12,30,2
day, hour, minute, config >3,12,30,3
day, hour, minute, config >
(TE) List | Insert | Remove | Enable | Disable | Status *>I
week 1-52 (0=all) >20
day,hour, minute, config >2,12,30,4
day,hour, minute, config >3,10,30,5
```

Displaying Timed Events

```
(T) Display | Set | Events >E
(TE) List | Insert | Remove | Enable | Disable | Status >L
event 1, - week 0, wk.day 1, hour 12, minute 30, configuration 1
event 2, - week 0, wk.day 2, hour 12, minute 30, configuration 2
event 3, - week 0, wk.day 3, hour 12, minute 30, configuration 3
event 4, - week 20, wk.day 2, hour 12, minute 30, configuration 4
event 5, - week 20, wk.day 3, hour 10, minute 30, configuration 5
```

Removing Timed Events

The operator may delete events by using the 'Remove' menu option and specifying the event number. The specified event will be deleted and all following events re-numbered. A consecutive range of events may be removed by specifying the start and end event.

(T) Display | **Set** | **Events** >**E**

(TE) List | **Insert** | **Remove** | **Enable** | **Disable** | **Status** >**R**

start event, end event >4,7

Enabling Timed Events

Once the timed events have been created they may be enabled using the 'Enable' menu option. The table will then be compared to the current real time value and the correct configuration automatically run.

(TE) List | **Insert** | **Remove** | **Enable** | **Disable** | **Status** >**E**

(TE) List | **Insert** | **Remove** | **Enable** | **Disable** | **Status** *>

Disabling Timed Events

In order to gain manual or network control of the multiplexer configuration selection, the timed events may be inhibited using the 'Disable' menu option. It is not possible to run a different configuration to that called for by a timed event unless the events are first disabled.

(TE) List | **Insert** | **Remove** | **Enable** | **Disable** | **Status** >**D**

(TE) List | **Insert** | **Remove** | **Enable** | **Disable** | **Status** *>

Determining Current Status

The current status of the timed events can be checked using the 'Status' menu option.

(TE) List | **Insert** | **Remove** | **Enable** | **Disable** | **Status** *>**S**

(0) timed events disabled or

(1) no current events or

timed events enabled, configuration 4 requested.

This indicates that the events are enabled and config 4 should be running.

5.3 System Mode Menu

5.3.1 Brief and Verbose Mode Selection

The power up state for these options are defined in the 'mOde' 'Install' menu, but can be overridden with this command. Brief mode is intended for test purposes or by an experienced programmer wishing to use a computer to download a configuration through the local port for example. The unit must be in verbose mode to operate with the NCS.

```
(O) Verbose | Brief | Echo | Noecho | Terminal | Install >B
*>
>
>V
```

```
(O) Verbose | Brief | Echo | Noecho | Terminal | Install *>
```

Note that in the above example when 'Brief' is selected the menu options are suppressed with the '>' character indicating that a command input is required.

5.3.2 Echo and Noecho Selection

The power up state for these options are defined in the 'mOde' 'Install' menu, but can be overridden with this command.

```
(O) Verbose | Brief | Echo | Noecho | Terminal | Install >N
```

This will inhibit the operator input from being returned to the operator terminal and will remove the CR/LF controls.

```
(O) Verbose | Brief | Echo | Noecho | Terminal | Install >E
```

This will restore the echo mode again.

5.3.3 Control Terminal Configuration

The multiplexer provides a menu for the purpose of setting the terminal type connected by the operator. This modifies the screen control characters issued by the multiplexer for screen display, e.g. the characters sent during a backspace.

```
(OT) Tty | Ansi | Wy-50 | Current >C
```

operator terminal = ANSI

5.3.4 Install Menu. E²PROM Programming

The operator may select a range of modes of operation using the 'Install' menu option. This will show the current setting and present each configurable mode option and allow the operator to change the setting. If no change is required then pressing the Return/Enter key will skip to the next item.

```
(O) Verbose | Brief | Echo | Noecho | Terminal | Install >I
Network letter is P (A - Z excluding N) >
Network number is 63 (1 - 63) >
Control port is local (0=local 1=a 2=b) >
Security is off (0=off 1=on) >
Start-up with echo (0=noecho 1=echo) >
Start-up in verbose (0=brief 1=verbose) >
Start-up fault logging is logging (0=off 1=logging 2=asr) >0
Redundant disabled (0=disabled 1=enabled) >
Expansion disabled (0=disabled 1=enabled) >
Alarm event detect period is 5 (0-60) >
Alarm event hold period is 5 (0-60) >
Alarm event channel card fault level is 16 (1-16) >
Network port A enabled (0=disable 1=enable) >
Network port B enabled (0=disable 1=enable) >
Network enabled (0=disable 1=enable) >
Network CRC Upload enabled (0=disable, 1=enable) >
Network CRC Upload Timer Offset 300 (180 to 720) >
Network C/D Upload enabled (0=disable, 1=enable) >
Network C/D Auto Clear enabled (0=disable, 1=enable) >
PSU A absent (0=absent 1=fitted) >
PSU B absent (0=absent 1=fitted) >
-48v absent (0=absent 1=fitted) >
Manage Port A baud rate is 1200 (600,1200,2400,9600) >
Manage Port B baud rate is 1200 (600,1200,2400,9600) >
Manag Config      1      5      10      14 D
System management 1, 1, 1, 1, 1, 1, 1, 1, 1, 1, 1, 1, 1, 1, 1 >
LIU 1 management1 1, 1, 1, 1, 1, 1, 1, 1, 1, 1, 1, 1, 1, 1, 1 >
LIU 1 management2 1, 1, 1, 1, 1, 1, 1, 1, 1, 1, 1, 1, 1, 1, 1 >
LIU 2 management1 1, 1, 1, 1, 1, 1, 1, 1, 1, 1, 1, 1, 1, 1, 1 >
LIU 2 management2 1, 1, 1, 1, 1, 1, 1, 1, 1, 1, 1, 1, 1, 1, 1 >
```

Severely errored second limit 805 (1-915) >

In the example above one parameter was changed. At the end of the options list the operator is then prompted to check if changes are to be permanently installed.

changes have been made, do you wish to install (Yes No) >Y

Saving installed modes completed ok!

(O) **V**erbose | **B**rief | **E**cho | **N**oecho | **T**erminal | **I**nstall *>

The modes of operation are stored in an E²PROM and the saving action can take up to one minute to complete. The E²PROM does not require battery back up and the information will be retained during power off conditions even if the battery is disconnected. When the multiplexer is being remotely controlled via an NCS and the install options are saved, the operator must wait for the 'completed OK' message to be displayed and then enter Ctrl + X to exit Remote control. If remote access is still required the multiplexer must be re-accessed.

Equipment Identity Code

The option to set a discreet identity code for each multiplexer is provided, except for N any letter from A to Z plus any number from 1 to 63 may be selected, e.g. P10. It is important that Z is not be used if the node is in a network under the control of the NCS version 3.1 or above as Z is used for zone identity. This will be the number displayed at root menu level (non secure mode) and also to identify faults. When under the control of the NCS, this ID code will be used by NCS to address that node, and therefore must not be duplicated on any other equipment in the network. If the equipment number is changed and the default password is in use, the password must be reset.

Control Port Selection

This option is used when the multiplexer is used in Local/Remote mode. The local multiplexer should be set to local and the remote multiplexer should be set to either 'a' or 'b' depending upon the selected management patchfield. When the unit is network managed it should be set to local.

Secure Mode Selection

The operator may use the multiplexer in secure mode, this enables the menu system to be 'closed' and a password will then be required at the local control port to gain access to the menu structure. The network ports 'a' and 'b' are not password protected.

Screen Display Modes

The start up (switch on) screen display may be set to echo/noecho or brief/verbose.

Fault Logging

The start up state of the fault reporting may be selected to Off, Logging or ASR. These reporting modes are described in Chapter 6.

Redundant Mode Operation

This facility must be enabled if a redundant system controller is fitted.

Expansion Mode Operation

This facility is not available in these multiplexers and must be set to disabled.

Alarm Event Detect Period

If a system configuration is programmed for an alarm event, then the alarm fault must exist for the specified period prior to the event occurring. The selection of a new system configuration will reset the detect period which must then be completed prior to a second event occurring. The detect period is the time in seconds. Note if 0 is set the detection period will be between 0 and <1 second.

Alarm Event Hold Period

The alarm event hold period determines the amount of time a new system configuration will be active prior to further alarm events being allowed to occur. The time is in seconds.

Alarm Event Channel Card Fault Level

The alarm level set will be used to determine the failure of any circuit specified as an alarm event source. The fault level is the NCS fault level which may be determined from the fault tables in Chapter 6.

Network Operation

The multiplexer may be operated on a network using the Network Control System (NCS), and this facility may be enabled or disabled. For local/remote working, network operation must be disabled.

CRC4, Counts and Durations Statistics gathering

The 3000 Series, build 6 or later, node supports enhancements to Network Management communications protocols to allow the efficient collection of CRC4, Counts and Durations statistics information from any node by the Network Control System. The Network CRC and Counts and Durations (C/D) install options allow these enhancements to be selectively turned on and off, and CRC4 upload delay to be adjusted.

Note that the following two items relate to a DomainView feature for collecting statistics, and do not affect the general operation of the multiplexer. For normal operation with NCS, these features must be disabled.

**1 Network CRC Upload enabled (0=disable, 1=enable) >
Network CRC Upload Timer Offset 300 (180 to 720) >**

This enables and disables the CRC4 upload function in the node. When enabled, at the end of every 15 minutes (on the hour, quarter past the hour etc) CRC4 analysis cycle, the node will signal to NCS that it has the CRC statistics for all the Dual LIUs fitted in the node. This will trigger the NCS to immediately request the data. In larger networks, it is advisable to stagger these 'uploads' to prevent networks being clogged with the CRC4 upload data from all the nodes. The Upload Timer Offset sets the delay in seconds from the 15 minute boundary to when the node signals it has CRC data available. In this way, it is possible to arrange that all the nodes do not signal simultaneously CRC data available.

**2 Network C/D Upload enabled (0=disable, 1=enable) >
Network C/D Auto Clear enabled (0=disable, 1=enable) >**

This enables and disables the C/D upload function in the node. This is normally a once per day event controlled by the NCS. When enabled, on receipt of the C/D command from NCS, it uploads all the Counts and Durations information from all the Dual LIUs fitted. When disabled, this command is ignored. If the auto clear is enabled, the Dual LIU automatically clears down all counts and durations after they have been read by NCS.

Power Monitoring

The power units in the 3000 power supply equipment can be monitored to indicate a fault on failure, this will occur if 'fitted' is selected. The operator should select 'fitted' when 2 power supplies are intended to be fitted in the chassis.

The -48VDC required for some channel interface cards and ringing generators is also monitored; if this is not used it should be set to 'absent'.

Management Configuration

The Baud rate for network management must be specified for each port, normally this is 1200, but must be set to the same baud rate as the NCS.

It should be noted that 9600 is only for local Test access to the Network Management UARTs on the System Controller and must not be used across the network.

Each management configuration (1-14+Default) specifies one of the seven patchfields available on the System Control cards and Dual LIU cards fitted in ports 1 and 2. Note that the patchfields for any Dual LIUs fitted in ports 3 and 4 are set by hardware switches. The display gives a configuration number index across the top and by reading the relevant column the patch selections can be determined. In order to modify the management the entire set of 15 numbers must be entered at the relevant line. The 'D' column specifies the patchfields selected for the default configuration which will be run if the unit becomes un-configured due to the backup battery becoming discharged.

Severely Errored second Limit

This sets the number of errors in any one second before it is classed as a severely errored second. If it is set to 915, the counter will be disabled.

5.3.5 Security Password Modification

This command allows the operator to set the password utilised when in secure mode. Note that this is a hidden menu option and requires the operator to enter Ctrl + W - ENTER to access it.

The password is in the form of up to 8 alphanumeric characters.

```
(O) Verbose | Brief | Echo | Noecho | Terminal | Install >^W  
(O) Set password | Display password | Password default *>S  
new password > SUNSHINE
```

Selecting 'Password Default' will set the password to the default which is ENETXX where XX is the equipment identity number. Note that if the equipment number is changed in the 'Install' menu, then 'Password default' must be re-selected otherwise the previous number will remain as part of the default password.

5.4 Configuration Menu

5.4.1 Checking and Running Channel Configurations

The operator must select 'Configure' 'Channel' (CC) from the root menu and may then display which is the 'Current' configuration, 'Run' a new configuration or enable/disable the 'Alarm events' for ALL configurations using the following menu commands.

(CC) **C**urrent | **R**un | **E**dit | **A**larm event >

5.4.2 Editing and Displaying Channel Configurations

Commands are provided to allow the operator to 'Load' either a previously edited configuration field or the default into an edit buffer. The edit buffer is where all changes are made by using the 'Modify' command, and is the 'configuration' viewed by the 'Display' command. After editing, another menu selection is provided for 'Saving' the buffer into a system configuration. If the save is into a configuration field that is already running, then the operator will be prompted to continue or abort. If continuing, the configuration is saved and run immediately.

(CC) **C**urrent | **R**un | **E**dit | **A**larm event >**E**

(CCE) **L**oad | **S**ave | **M**odify | **O**rigin | **D**isplay >**L**
configuration no | **D**efault >2

(CCE) **L**oad | **S**ave | **M**odify | **O**rigin | **D**isplay >**S**
configuration no | **D**efault >1

Warning configuration is current - continue **Y**es | **N**o >

After loading the desired configuration in to the edit buffer, the operator may select the 'Modify' or 'Display' command in order to modify or display its contents. In order to check where the last edit buffer load was made from, the 'Origin' option is provided.

Timeslot allocation and routing through the multiplexer is carried out in two separate stages:

- i) Timeslots from the Port in which the card is inserted have to be assigned to the relevant circuit on the card, using the 'Assigned cct' command.
- ii) These timeslots may be routed through the switch to any destination using the 'Cross Connect' menu option. (Refer to Figure 1-1).

The following descriptions of configuration options show the 'Modify' and 'Display' formats for each option.

Port Integrated Menu Support

The 3000 Series provides integrated menu support for some channel cards, e.g. Dual Nx64 LIU and Dual G.703 DLIU. Refer to the channel card manuals for the menus provided for all cards except Dual G.703 LIU which is covered in this manual.

Integrated menu support can be accessed via Modify Port p1 option for a card fitted in port 1, Modify Port p2 for card fitted in port 2. On selection of Modify Port p3 and p4 options, the user is given the option to select the card slot A, B... for each physical port.

If the card fitted in that slot has integrated support, the appropriate menus will be displayed seamlessly. If the card fitted is not supported in that slot, the 'Not available on card fitted or card missing' message will be issued.

5.4.3 DLIU Integrated Menu

A Dual G.703 LIU fitted in port 1 and 2 is configured using the following menu structure. Dual LIU cards fitted in ports 3 and 4 are configured using the 'Smart' menu option as described in the Dual LIU manual.

Modify Format

This command allows the user to set the operating parameters for ports 1 and 2 when fitted with a Dual LIU card DTE241.

(CCEM) **Port** | sYnc | **Alarms** | **Cross connect** >**P**

(CCEMP) **Assigned cct** | **Circuit ctl** | **Smart configs** | p1 | p2 | p3 | p4 >1

(CCEMP1) sYnc | **F code** | **Bypass** | **Mode** | **Error** | cRc4 | **Alarm** | **Ts assign** >

1) Sync

This will allow the operator to set the parameter for detecting the loss of the incoming signal when it is used as a synchronising source. This can be either:-

- 1 Line Loss
- 2 Line Loss or Service Loss
- 3 Line Loss, Service Loss or receipt of a Remote Alarm. (Bit 3 in TS0)
- 4 Line Loss or receipt of a Remote Alarm

Service Loss is defined as: loss of Frame sync, AIS or a 10^{-3} error rate.

These parameters may be set individually for line 1 or line 2.

The user may also select the state (enabled or disabled) of the G.703 clock output when the multiplexer is free running via G.703 Clk o/p menu.

2) F code

This will allow the on-going data in each timeslot and associated signalling to be determined should the source data fail. The data may be set individually for line 1 and line 2. Note: 'F' Codes are overwritten with FFH when the respective timeslot is a multipoint timeslot.

3) Bypass

The bypass condition for the lines, i.e. connecting line 1 to line 2, or for the clock, i.e. connecting clock I/P to clock O/P may be set. If set to enabled, the Line or Clock circuits will be permanently bypassed for that configuration. The normal setting is disabled which will allow the circuits to automatically switch to 'Bypass' should the card fail, be removed or during power failure.

4) Mode

Three modes of operation may be set. If firmware DT986/6 is fitted to the Dual LIU, additional options are provided for each mode to set the routing for the TS0 'Not Frame alignment Word' (NFW) There are 8 options which are fully described in section 3.1.1.

1 Multipoint.

This will connect all timeslots and signalling through from line 1 to line 2, and provide the facility to multipoint additional timeslots from the multiplexer switch, or to drop and insert individual timeslots from either line to the multiplexer switch. Line 1 and line 2 must be in the same signalling mode, i.e. CAS or CCS. Fault logging may also be individually enabled or disabled for line 1 or line 2.

If fault logging is disabled, faults will not be reported from that line signal and may be used if a line is to be taken out of service. If multiframe linking is selected, the delay between multiframes received on line 1 and transmitted on line 2 will be minimised. Similarly, the delay between multiframes received on line 2 and transmitted on line 1 will be minimised.

Note: When multiframe linking is enabled, incoming frame slips will cause multiframe re-alignment and Frame Sync loss may occur

momentarily on the host equipment and also on equipment connected to the host.

2 Terminal.

This will isolate line 1 from line 2 providing two separate PCM paths to the cross connect switch. Signalling may be different on line 1 and line 2 (CAS or CCS) and fault logging may be individually set as for multipoint.

In terminal mode, the mapping of PCM timeslots to the backplane streams is fixed. The selection of 'TS Assign' menu is inhibited, and user will be warned that this option is 'Not available in this mode'.

In port 1, line 1 is connected to backplane stream s1, line 2 to s2. In port 2, line 1 is connected to backplane stream s3, line 2 to s4. In all cases PCM timeslots 1, 2, 3,...31 are connected to backplane stream timeslots 1, 2, 3,...31.

3 A/B Switching.

This mode is designed to change from one line to another upon a specific line failure. All timeslots for both outgoing line streams will be sourced from the relevant stream (S1 for port 1 or S3 for port 2) and all timeslots from the active line signal will be connected to the relevant stream as indicated below. The mapping of PCM timeslots to the backplane streams is fixed with TS1, 2, 3,...31 of the backplane stream. The selection of 'TS Assign' menu is inhibited, and user will be warned that this option is 'Not available in this mode'.

The operator can set the following options:

i) Signalling mode

This must be the same for both PCM streams; either CAS or CCS.

ii) Switch over delay (Fault Persistency)

This delay parameter will be used to inhibit change-over of the PCM source until the PCM fault has been present for the delay period.

iii) Hold delay

This parameter will be used to disable operation of the switch over facility immediately after a change-over. The facility will be re-enabled after the delay period has expired.

Note: Both the switch over delay timer and the hold delay timers run in parallel and not consecutively therefore the hold delay must

be set greater than the change over delay by the amount of hold period that is required.

Time delays are selectable between 0 and 25 seconds in steps of 100ms.

iv) Dual management path

When this facility is enabled, management data will operate as in terminal mode e.g.

- i) TS0 data from line 1 will be written to line 1 patchfield.
- ii) TS0 data from line 2 will be written to line 2 patchfield.
- iii) Data read from line 1 patchfield will be written to line 1 TS0.
- iv) Data read from line 2 patchfield will be written to line 2 TS0.

When disabled, this facility will operate as follows:

- i) Data read from the active line signal will be written to the relevant active portion of the patchfield.
- ii) Data written to the inactive portion of the patchfield will be all 1's.
- iii) Data read from line 1 patchfield will be written to line 1 TS0.
- iv) Data read from line 2 patchfield will be written to line 2 TS0.

v) A/B sync source tracking

This facility can be enabled or disabled.

When enabled, the sync source used from this LIU will automatically be derived from the active line. This clock should be selected in the multiplexer sync plan as Line 1 clock. Line 2 clock is not used.

When disabled, Line 1 and Line 2 clocks may be used as sync sources in the multiplexer sync plan in the normal way.

Failure Conditions

The following faults are used to determine a line failure condition.

AIS

Loss of Incoming PCM

Loss of Frame alignment

Error ratio > 1 in 10^{-3}

TS16 AIS if set for CAS mode

Loss of Multiframe alignment if set for CAS mode

Low error rate

CRC reframe when CRC is enabled.

Change-over Operation

The decision to switch or not to switch will be made on the basis of the table below when the delay time expires. Faults which occur and clear within the switch over delay time will not be considered for the purposes of the decision table.

ACTIVE STREAM	STANDBY STREAM	ACTION
No fault	No fault	None
Low error rate	No fault	Switch
Low error rate	Any fault	None
Any fault except low error rate	Low error rate	Switch
Any fault except low error rate	Any fault except low error rate	None

Faults

During failure conditions, PCM alarm responses will be set and reported as for normal PCM operation of the LIU. If PCM Line 1 is selected, the following status message will be generated in the active fault list:-

'Path A selected'.

Similarly if PCM Line 2 is selected, the following status message will be generated:-

'Path B selected'.

These 'faults' are used as information markers, and have a network fault level of zero and cause no alarm relay or LED operation.

Fault Persistency

One fault may cause the change over timer to start running, but that same fault need not be active when change-over occurs, another fault may take its place, e.g. PCM loss occurs and is then replaced by AIS. Only when all relevant faults have been cleared will the timer be reset.

5) Error

The threshold for the low error rate detector may be individually set to 10^{-4} , 10^{-5} or 10^{-6} for line 1 and line 2. This does not affect detection of 10^{-3} which is required for line service monitoring. If the threshold is exceeded, then the low error rate fault is generated.

6) CRC4

The CRC4 error checking facility may be individually enabled or disabled for line 1 and line 2. If CRC4 is enabled, the user has the option to enable/disable the low error rate detection using CRC4. If enabled, the low error rate is calculated using CRC4. If disabled, the low error rate is calculated using the timeslot zero frame word. Note that CRC4 must be enabled at BOTH ends of the PCM stream otherwise data loss, including loss of the management path, will occur due to CRC Reframe causing loss of Frame sync.

7) Alarm

This allows the user to define the conditions for detecting the loss of incoming signal when it is used to trigger an alarm event. The parameters can be individually set for line 1 and line 2 and are the same as those for sync (5.4.3 1)).

8) Ts Assign

DUPLEX

This method of timeslot assignment should be used where the Dual LIU is required to operate in Multipoint (Drop/Insert) mode. Selecting 'Duplex' allows individual timeslots to be dropped/inserted to either Line 1 or Line 2 timeslots from the matching timeslots on the cross-connect switch. In port 1: line 1 is connected to S1; line 2 to S2. In port 2: line 1 is connected to S3; line2 to S4. To make the connection, select the line required, 1 or 2, and then enter 'E' for the timeslot it is required to Drop/Insert. In the following example timeslots 1 and 2 will be dropped /inserted from P1 Line 1 to timeslots 1 and 2 of S1. Timeslots 1 and 2 in Line 2 will be replaced by the Fcode since they are no longer connected through to Line 1. Alternatively they may be reused and dropped/inserted to S2.

```
(CCEM1T) Multipoint | Duplex >D
(CCEM1TD) Line 1 | Line 2 >1
first timeslot, last timeslot >1
(TS1,          ) *>E
(TS2,          ) *>E
(TS3,          ) *>
(TS4, Duplex ) *>
```

Up to 31 timeslots may be selected and timeslots which are already connected will be shown as 'Duplex'. To disconnect an allocated timeslot enter U.

MULTIPOINT

Selecting multipoint operation is exactly the same as 'Duplex' except that the timeslots are also allowed to pass through from Line 1 to Line 2 in duplex as well as being dropped/inserted to the relevant stream on the cross connect switch. The timeslot from the switch is multipointed (logically 'ANDed') with the through timeslot from the other line. The display will show 'Multipoint' instead of 'Duplex'.

Display Format

This command allows the display of all of the parameters set above.

```
(CCED) Port | sYnc | Alarms | Cross connect >P  
(CCEDP) Assigned cct | Circuit ctl | Smart configs | p1 | p2 | p3 | p4 >1  
(CCEDP1) sYnc | F code | Bypass | Mode | Error | cRc4 | Alarm | Ts assign >  
Each parameter may be selected for display only - no changes are possible.
```

5.4.4 Sync Source

A menu command allows the operator to modify the sync source and sync priority selections for the configuration of the multiplexer. Up to four sync source selections can be entered after which the list will be terminated with free run.

Modify Format

Each sync source selected will be displayed in turn until freerun is reached. The last sync source in any selection will always be free run.

```
(CCEM) Port | sYnc | Alarms | Cross connect >Y  
failure recovery mode 1 (manual), 2 (automatic)  
mode = 2 >  
automatic recovery delay period 1-60 (seconds)  
hold = 10 >
```

source selections:

```
1 (port)  
2 (8k1)  
3 (8k2)  
4 (free run)  
priority 1 = 4 (free run) >1
```

```
port (1,2,3,4),card,option (1=line1 2=line2 3=clk)>3, C, 2
priority 2 = 4 (free run) >1
port (1,2,3,4),card,option (1=line1 2=line2 3=clk)>2, A, 1
priority 3 = 4 (free run) >
(CCEM) Port | sYnc | Alarms | Cross connect *>
```

If manual clock recovery is selected, the multiplexer will automatically fallback to a lower priority clock, but will only re-select a higher priority clock by manually re-running the current configuration. If automatic clock recovery is selected the sync source will automatically revert to the highest good source available. The switch back may be delayed for up to 60 secs from when the good clock is first detected.

The Series 3000 can be synchronised to a 2MHz or two 8kHz, known as 8k1 and 8k2, internal clock busses generated by certain channel cards. Access to the 2MHz clock bus is fully controlled by the system controller. However, access to the 8kHz busses are not. This is controlled by link selection on the channel cards. Care should be taken to ensure only one channel card is connected to each of the 8kHz clock busses at any one time.

The 'port' selection allows the user to select channel cards which supports 2048 kHz clock bus as the sync source multiplexer. In the example above, the line 2 of the card fitted in port 3, card slot c has been selected as the priority 1 clock source. Selection of the clocks is automatic.

8k1, 8k2 options allow the user to select the 8k1, or 8k2 busses as the sync source.

Display Format

```
(CCED) Port | sYnc | Alarms | Cross connect >Y
recovery mode (2) automatic
clock priority 1 sourced from port 1, card A, line 2
clock priority 2 sourced from port 2, card A, line 1
clock priority 3 sourced from freerun
(CCED) Port | sYnc | Alarms | Cross connect *>
```

5.4.5 Alarm Events, Route Alarms and External Control Relays

Each configuration may be set to run another configuration on a specified fault condition. The condition can be set to be the failure of an incoming PCM stream or a fault on a channel card which must exist for a period defined within the 'Mode Install' menu.

Up to eight circuits may be identified as 'Route alarms' for use by the NCS for re-routing purposes. They have no use in non-networked mode.

Four relays are provided on the 3200 for control of attached equipment. These relays may be set to operate as required for different configurations.

5.4.5.1 Alarm Events

Modify Format

```
(CCE) Load | Save | Modify | Origin | Display *>M
(CCEM) Port | sYnc | Alarms | Cross connect >A
(CCEMA) Alarm event | Route alarms | Extern relays | Card out >A
enter start stream, start circuit >S1
config. options 1-14 (U = unassigned)
(S1) alarm config. 1 >
(S2) alarm config. Unassigned >8
(S3) alarm config. 1 >4
(S4) alarm config. Unassigned >
(CCEMA) Alarm event | Route alarms | Extern relays *>
(CCEM) Port | sYnc | Alarms | Cross connect >A
(CCEMA) Alarm event | Route alarms | Extern relays | Card out >A
enter start stream, start circuit >P3, A1
config. options 1-14 (U = unassigned) >
(P3, cct A1) alarm config Unassigned >
(P3, cct A2) alarm config 4 >
(P3, cct A3) alarm config Unassigned >
(P3, cct A4) alarm config Unassigned >5
(CCEMA) Alarm event | Route alarms | Extern relays *> | Card out >A
```

PCM streams for Dual G.703 LIU cards in port 1 and 2 should be entered as S1 for Port 1 Line 1, S2 for Port 1 Line 2, S3 for Port 2 Line 1, and S4 for Port 2 Line 2. Other channel cards e.g. Dual Nx64 LIU should be entered as P1, A1 for Port 1 circuit 1, P1, A2 for Port 1 circuit 2 etc.

Display Format

```
(CCED) Port | sYnc | Alarms | Cross connect >A
(CCEDA) Alarm event | Route alarms | Extern relays | Card out >A
S2, alarm config 1
S3, alarm config 8
S4, alarm config 4
P3, cct A2 alarm config 4
```

P3, cct B2 alarm config 5

The display option will list all sources of alarm events that are currently assigned.

With the alarm event triggers set in the configuration, the operator must then 'Enable' the alarm events before they will function.

(CC) **C**urrent | **R**un | **E**dit | **A**larm event >**A**

(CCA) **E**nable | **D**isable | **S**tatus >**E**

To disable alarm events so that a change of PCM status does not cause a configuration change, the 'Disable' menu option should be selected.

(CCA) **E**nable | **D**isable | **S**tatus >**D**

In order to check the current alarm event mode, the 'Status' option may be selected.

(CCA) **E**nable | **D**isable | **S**tatus >**S**

alarm events currently disabled.

5.4.5.2 Route Alarms

Modify Format

(CCEMA) **A**larm event | **R**oute alarms | **E**xtern relays | **C**ard out >**R**

(Route 1) Stream 1 >

(Route 2) Stream 2 >

(Route 3) Stream 3 > P4,B2

(Route 4) Stream 4 > S3

(Route 5) Port 3, Circuit A1 >

(Route 6) Port 3, Circuit A2 >S4

(Route 7) Port 4, Circuit A1 >

(Route 8) Port 4, Circuit A2 > P4,B1

(CCEMA) **A**larm event | **R**oute alarms | **E**xtern relays | **C**ard out *>

The default circuits for route alarms 1 to 8 are listed in Sec 5.4.18 (10). Route alarms can not be unassigned, but do not have to be used by the NCS. PCM streams for Dual G.703 LIU cards in ports 1 and 2 should be entered as S1 to S4. Other channel cards, e.g. dual Nx64k cards in ports 1 and 2 should be entered as P1,A1 - P1,A2 - P2,A1 - P2,A2.

Display Format

(CCEDA) Alarm event | Route alarms | Extern relays | Card out >R
(Route 1) Stream 1
(Route 2) Stream 2
(Route 3) Port 4, Circuit B2
(Route 4) Stream 3
(Route 5) Port 3, Circuit A1
(Route 6) Stream 4
(Route 7) Port 4, Circuit A1
(Route 8) Port 4, Circuit B1
(CCEDA) Alarm event | Route alarms | Extern relays *>

5.4.5.3 External Relays

Modify Format

(CCEMA) Alarm event | Route alarms | Extern relays | Card out >E
(CCEMAE) ext 1 | ext 2 | ext 3 | ext 4 >1
ext 1 Disabled (0=disable 1=enable) >1
(CCEMAE) ext 1 | ext 2 | ext 3 | ext 4 *>

This action will cause external relay number one to be operated when the configuration is run.

Display Format

(CCEDA) Alarm event | Route alarms | Extern relays | Card out >E
ext 1 relay Enabled
ext 2 relay Disabled
ext 3 relay Disabled
ext 4 relay Disabled
(CCEDA) Alarm event | Route alarms | Extern relays | Card out *>

5.4.5.4 Card Out

This allows the user to configure an alarm event to be triggered by the removal of a card from Port 1 or Port 2

Modify Format

(CCEMA) Alarm event | Route alarms | Extern relays | Card out >C
enter start port> P1
config options 1-14 (U=unassigned)

(P1 card out) alarm config Unassigned> 1
(P2 card out) alarm config Unassigned> 1
(CCEMA) Alarm event | Route alarms | Extern relays | Card out >C

Display Format

(CCEDA) Alarm event | Route alarms | Extern relays | Card out >C
(P1 card out) alarm config 1
(P2 card out) alarm config 1
(CCEDA) Alarm event | Route alarms | Extern relays | Card out >C

5.4.6 Circuit Assignments

(CCEM) Port | sYnc | Alarms | Cross connect >P
(CCEMP) Assigned cct | Circuit ctl | Smart configs | p1 | p2 | p3 | p4 >

The 'Assigned cct' menu command provides the facility for assigning circuits to the timeslots associated with each port and for setting the value of the TS control byte used on VF channel cards. This value need not be entered if the TS control port is not used, or is unchanged.

Modify Format

(CCEMP) Assigned cct | Circuit ctl | Smart configs | p1 | p2 | p3 | p4 >A
port, first, last timeslot >P4
(P4,TS 1) cct = , TS control = 00000000B >A1, 10001010B
(P4,TS 2) cct = , TS control = 00000000B >A2

The first timeslot to be assigned may be selected to be TS0 to TS31. If no first timeslot is selected, TS1 will be presented as in the example above.

This menu option also supports a block assignment mode. If values are entered for the first and last timeslot, then only one circuit i.d. will be requested. All timeslots in the range will then be allocated to the designated circuit. Note that this mode should only be used for circuits supporting multiple timeslots. The timeslots will be consecutively allocated to the circuit. The TS control byte can not be altered without first re-entering the circuit identity.

Display Format

(CCEDP) Assigned cct | Circuit ctl | Smart configs | p1 | p2 | p3 | p4 >A
port, first, last timeslot >P4, 10, 12
(P4,TS,10), cct = A1 , TS control = 10001010B
(P4,TS 11), cct = A2 , TS control = 00000000B
(P4,TS 12), cct = A3 , TS control = 00000000B

5.4.7 Circuit Controls

This menu command provides a facility for setting and displaying the two control ports for the channel cards in any port. If only control port 1 is used a value for control port 2 need not be entered. Refer to the relevant channel card manual for control port byte values.

Modify Format

```
(CCEMP) Assigned cct | Circuit ctl | Smart configs | p1 | p2 | p3 | p4 >C
port, first cct >P3, A1
(P3, cct A1, TS 14), 1 = 11111011B, 2 = 11111111B > FFH
(P3, cct A2, TS 15), 1 = 11111011B, 2 = 11111111B > A5H
(P3, cct A3, TS 17), 1 = 11111011B, 2 = 11111111B > 11011011B
(P3, cct A4, TS 18), 1 = 11111011B, 2 = 11111111B > 11011101B, 10110101B
```

Display Format

```
(CCEDP) Assigned cct | Circuit ctl | Smart configs | p1 | p2 | p3 | p4 >C
port, first cct >P4 A1
(P4, cct A1, TS 5),control 1 = 11111111B, control 2 = 11111111B
(P4, cct A2, TS 6),control 1 = 10100111B, control 2 = 11111111B
(P4, cct A3, TS 7),control 1 = 11011011B, control 2 = 11111111B
(P4, cct A4, TS8 ),control 1 = 11011101B, control 2 = 10110101B
```

5.4.8 Smart Configurations

Each channel configuration must specify an associated configuration number for each smart channel card installed. When a system channel configuration is run this information is then used to determine the correct smart channel card configuration numbers. Smart cards can have up to four configurations.

Modify Format

```
(CCEMP) Assigned cct | Circuit ctl | Smart configs | p1 | p2 | p3 | p4 >S
port 1 card A smart config 1 >
port 2 card A smart config 1 >
port 3 card A smart config 4 >3
port 3 card C smart config 2 >
port 4 card E smart config 2 >
```

Note that only the port card positions actually installed with smart channel cards are displayed and made available for modification.

If port 1 or Port 2 is fitted with a Dual LIU card DTE241 the config requested should be ignored; these would be used if the ports were fitted with, for example, a T1 Line access card.

Display Format

```
(CCEDP) Assigned cct | Circuit ctl | Smart configs | p1 | p2 | p3 | p4 >S
port 1 card A smart config 1
port 2 card A smart config 1
port 3 card A smart config 3
port 3 card C smart config 2
port 4 card E smart config 2
```

5.4.9 Fixed Code Table

A Menu command allows the user to modify the fixed code table. There are 16 codes available and these may be changed to suit operator requirements for timeslot data and associated signalling data. When configuring 'Fixeddata' it is only necessary to select the code number.

Modify Format

```
(CCEMC) Fcode table | Channel assign >F
Fcode no (1 to 16) >1
1 data, signal = FFH; FH >
2 data, signal = FFH; FH >AAH,AH
3 data, signal = FFH; FH >55H,5H
4 data, signal = FFH; FH >01H,FH
5 data, signal = FFH; FH >
6 data, signal = FFH; FH >
7 data, signal = FFH; FH >
8 data, signal = FFH; FH >
9 data, signal = FFH; FH >
10 data, signal = FFH; FH >
11 data, signal = FFH; FH >
12 data, signal = FFH; FH >
13 data, signal = FFH; FH >
14 data, signal = FFH; FH >
15 data, signal = FFH; FH >
16 data, signal = FFH; FH >
```

Display Format

(CCEDC) **F**code table | **C**hannel assign | **M**ultipoint | **B**roadcast >**F**

Fcode no 1 = FFH, FH

Fcode no 2 = AAH, AH

Fcode no 3 = 55H, 5H

Fcode no 4 = 01H, FH

Fcode no 5 = FFH, FH

Fcode no 6 = FFH, FH

Fcode no 7 = FFH, FH

Fcode no 8 = FFH, FH

Fcode no 9 = FFH, FH

Fcode no 10 = FFH, FH

Fcode no 11 = FFH, FH

Fcode no 12 = FFH, FH

Fcode no 13 = FFH, FH

Fcode no 14 = FFH, FH

Fcode no 15 = FFH, FH

Fcode no 16 = FFH, FH

5.4.10 Cross-Connection configuration

The stream numbers on the cross-connect switch directly relate to the PCM lines of Dual LIU cards as follows:

S1	Port 1 line 1	S3	Port 2 line 1	
S2	Port 1 line 2	S4	Port 2 line 2	See section 1 Figure 1-1

Timeslots may be cross-connected between any stream, between any port or between any stream and port without restriction e.g. P3 timeslot 8 to S3 timeslot 27. The cross connection may be Simplex (unidirectional) or Duplex (bi-directional). In Duplex it is only necessary to configure one direction and the return path will be automatically assigned. The first timeslot to be assigned may be selected to be TS0 to TS31 for all ports and streams. If no first timeslot is selected, TS1 will be presumed.

Note that cross-connection of a timeslot to TS0 or TS16 of a Dual LIU (S1 to S4) can be made with no error message. Normally, the TS0 timeslot data on the backplane will be overwritten by the framing in the PCM stream. PCM TS0 NFW bits can be accessed via Dual LIU patchfields for management purposes or routed via the DLIU TS0 routing options. If the line is in CAS mode the TS16 backplane timeslot data will also be overwritten with the multiframing in the PCM stream.

Modify Format

The modification of the timeslot cross-connection is available with the following format:

Example 1

```
(CCEMCC) Simplex | Duplex | Fixeddata assign | Multipoint >D
output stream, start timeslot, end timeslot >S1
(S1; TS 1; Fixeddata ; ) from, TS, = ; >S2,1
(S1; TS 2; Fixeddata ; ) from, TS, = ; >S2,2
(S1; TS 3; Fixeddata ; ) from, TS, = ; >S2,3
```

In the above example the operator has only entered the output stream for modification. The system then responds with the request for a source stream and timeslot assignment starting at timeslot 1 of the output stream selected i.e. S1. If the operator wanted to start at a particular timeslot, including TS0, this could have been entered. The prompt for an assignment would then start at the timeslot supplied as follows:

Example 2

```
(CCEMCC) Simplex | Duplex | Fixeddata assign | Multipoint >D
output stream, start timeslot, end timeslot >P4, 22
(P4; TS 22; Fixeddata ; ) from, TS, = ; >S2,1
(P4; TS 23; Fixeddata ; ) from, TS, = ; >P3,2
(P4; TS 24; Fixeddata ; ) from, TS, = ; >S1,1
```

In examples 1 and 2 the operator has elected to assign timeslots to streams one at a time. If the operator wanted to assign a block of timeslots to a stream then both the start and end timeslots would be supplied as in the following example:

Example 3

```
(CCEMCC) Simplex | Duplex | Fixeddata assign | Multipoint >D
output stream, start timeslot, end timeslot >P4,1,10
(P4; TS 1; Fixeddata ; ) from, TS, = ; >S2,4
output stream, start timeslot, end timeslot >
```

In example 3 the operator has cross connected a contiguous block of 10 timeslots to port 4. Port 4 timeslots 1, 2, 3 to 10 are sourced from stream S2 timeslots 4, 5, 6 to 13 respectively. Note that the menu system only prompts for a single cross-connection source assignment when using block mode. The prompt then returns for another output stream selection. If the assignment supplied does not have the required range then an error

message is returned and no assignments are made as in the following example:

Example 4

```
(CCEMCC) Simplex | Duplex | Fixeddata assign | Multipoint >D
output stream, start timeslot, end timeslot >P4,22,31
(P4; TS 22; Fixeddata ;) from, TS, = ; >S2,28
error, source timeslots out of range!
output stream, start timeslot, end timeslot >
```

Because the end of the available source stream timeslots were reached before the output stream was complete (10 timeslots required) an error was generated. No assignments would have been made and the operator must then enter the correct source or escape back to the main menu.

Nx64k Cross-connection

For Nx64k data groups, the time delay through the network must be the same for all timeslots. This requires some care when configuring the multiplexer's cross connection.

If possible, configure the cross connection so that the offset between each of the source timeslots within the Nx64k block and the associated output timeslots of the Nx64k block are the same.

For example, consider the simplex block cross connection. P3,TS1 to 3 cross connected to P4,TS 5 to 7. This is made up of 3 separate simplex cross connections: P3,TS1 to P4,TS5; P3,TS2 to P4,TS 6; P3,TS3 to P4,TS 7. The offset $TS5(6,7)-TS1(2,3)$ is 4 for all connections.

If differing offsets have to be used:

- 1) Do NOT use an offset of +2, e.g. if the source TS=5, and the output TS=7, then offset = +2.
- 2) For the forward direction mark the check diagram below as follows:
 - i) Mark the first source TS
 - ii) From this position drop vertically to the output TS scale.
 - iii) If this is not the required output TS move to the right until the first ident for the first output timeslot is reached.
 - iv) Draw a line from the output TS to the input TS.
 - v) Repeat (i) to (iv) for each timeslot pair.

- 3) repeat 2) for the return direction on a separate diagram.
- 4) If any lines cross on either the forward or the return diagrams the cross-connections will give an invalid Nx64k data path.

0	0	0	1	1	2	2	2	3
0	4	8	2	6	0	4	8	1
.....								

Source Time Slot

0	0	0	1	1	2	2	2	3	0	0	0	1	1	2	2	2	3
0	4	8	2	6	0	4	8	1	0	4	8	2	6	0	4	8	1
.....																	

Output Time Slot

Fig 5.1 TIMESLOT CHECK DIAGRAM FOR Nx64k OPERATION

Display Format

The display of the cross-connections are available in the following format:

(CCEDC) **F**code table | **C**hannel assign | **M**ultipoint | **B**roadcast >**C**
output stream >**S**1
(S1, ts 1, **D**uplex ,) from P3, TS 4,
(S1, ts 2, **F**ixed data ,) Fcode 1
(S1, ts 3, **S**implex ,) from S2, TS 5
(S1, ts 4, **M**ultipoint ,) from S2, TS 9

5.4.11 Fixed Data Assignment

The Fixed Data mode allows a permanent fixed code to be output in the assigned timeslots and CAS signalling channels. The operator should enter the Fcode number (1-16) from the Fcode table and not the data itself.

Allocating fixed data is the only means of disconnecting a cross connection.

If the cross connection is in Duplex it is necessary to individually assign fixed data for each direction otherwise a Simplex connection will remain.

(CCEMCC) **S**implex | **D**uplex | **F**ixeddata assign | **M**ultipoint >**F**

output stream , timeslot >S1,1

(S1; TS 1; Duplex) data Fcode= >4

(S1; TS 2; Duplex) data Fcode= >3

(S1; TS 3; Duplex) data Fcode= >5

(S1; TS 4; Duplex) data Fcode= >5

(S1; TS 5; Duplex) data Fcode= >

(S1; TS 6; Duplex) data Fcode= >9

5.4.12 Multipoint Timeslot Assignment

The user may program a stream timeslot to be in multipoint operation. This will cross-connect a timeslot (and signalling) from any source stream or port entered first, and then combine it with other timeslot(s) which must be from port 3 using an 'AND' function.

Only the outgoing timeslot, towards the multipoint master, requires to be set to multipoint mode. The outgoing timeslots to the multipoint slaves will automatically be set to broadcast data (and signalling) from the master.

IMPORTANT NOTE: *If Multipointing is enabled, a channel card must NOT be fitted in port 1. It may be left empty or fitted with a Dual LIU.*

Modify Format

(CCEMCC) **S**implex | **D**uplex | **F**ixeddata assign | **M**ultipoint >**M**

(ECEMCCM) **E**nable | **D**isable >**E**

output stream, timeslot >S1

(S1; TS 1; Simplex ;) from, TS = ; >P4,1,P3,2,P3,5

(S1; TS 2; Duplex ;) from, TS = ; >S4,2,P3,6,P3,7

(S1; TS 3; Fixeddata ;) from, TS = ; >S3,8,P3,18,P3,9,P3,23

Display Format

(CCEDC) **F**code table | **C**hannel assign | **M**ultipoint | **B**roadcast >**M**
output stream, timeslot >S1
(S1, TS 1, Multipoint ,) from P3, 2, P3, 5, P4,1
(S1, TS 2, Multipoint ,) from P3, 6, P3, 7, S4,2
(S1, TS 3, Multipoint ,) from P3,18, P3, 9, P3, 23, S3, 8

Note that the first timeslot entered is displayed as the last, since it will have the longest delay through the cross-connect switch.

5.4.13 Cross Connect Broadcast Display

In assigning output streams to source streams it is possible to obtain a broadcast assignment. This is where one input timeslot is assigned to more than one output timeslot. In order to be able to establish this occurrence a 'Broadcast' display menu option is provided. When selected this prompts for an input stream and timeslot and then lists all output streams and timeslots assigned to it.

(CCEDC) **F**code table | **C**hannel assign | **M**ultipoint | **B**roadcast >**B**
input stream, timeslot >S2,6
broadcasts to outgoing S3, timeslot 9
broadcasts to outgoing P3, timeslot 5
broadcasts to outgoing S1, timeslot 18

5.4.14 Edit Buffer Origin Display

The edit buffer 'Origin' option will display the source (if known) of the data within it. On loading the edit buffer the origin will become the number of the configuration from which it was loaded. If it is modified a message to this effect will be displayed. If the edit buffer is then saved, the origin will become the number of the configuration field into which it was saved.

(CCE) Load | **S**ave | **M**odify | **O**rigin | **D**isplay >**O**
Edit source from configuration 4 and modified

5.4.15 Checking and Running Management Configurations

The assignment of management patchfields to configurations is set-up in the 'mOde' - 'Install' menu.

This management menu specifies which management configuration is to be run. Operation of the 'Current' and 'Run' commands is the same as for the channel configuration commands.

(C) **C**hannel | **M**anagement | **L**ink | **S**tatus | **E**quipment map >**M**
(CM) **C**urrent | **R**un >

5.4.16 Management Configuration Linking

The management menu incorporates a menu option for the linking of management configuration changes to channel configuration changes. In linked mode, the management configuration would be re-selected with every new channel configuration and/or timed event change. Each channel configuration field will run the management configuration with the same ID number if 'link' is enabled. Under NCS control the linking of configurations is ignored.

Setting Link Mode

(C) Channel | Management | Link | Status | Equipment map >L
0=separated 1=Linked (current = 0) >1

With configurations linked, a channel configuration change to config 8 would change the management configuration to config 8.

Setting Separate Mode

(C) Channel | Management | Link | Status | Equipment map >L
0=separated 1=Linked (current = 1) >0

In separate mode, the management configuration would only change if the operator or network controller gave a command to do so.

When the status of the 'Link' changes from 'Separate' to 'Linked', the management configuration will not change until the next channel configuration change.

Checking Link Status

(C) Channel | Management | Link | Status | Equipment map >S
Link =1 management currently linked to channel config

5.4.17 Equipment Map Editing

The equipment map contains a list of the cards mapped in the system and those actually fitted. Each card type is identified by its card identity code on the status ports. This allows a fault to be raised, called a 'Map mismatch' if a card is removed, or an incorrect card type is inserted.

All smart channel cards *MUST* be entered into the equipment map for correct operation and should be done before configuring them.

Cards must be removed from the equipment map in order to clear the map mismatch fault after a card has been removed from the chassis. If a card is fitted, but is not installed in the equipment map for that card slot, a map mismatch fault will not be raised and fault logging from that card will be inhibited.

Listing Current Map

(C) Channel | Management | Link | Status | Equipment map >E

A list of all cards mapped in or fitted is obtained by selecting 'List'.

(CE) List | Install | install All | Remove | iDent >L

Card Position	Map	Fitted
P1,A	DT310	DT310
P2,A	none	none
P3,A	none	DT310
P3,B	none	none
P3,C	none	none
P3,D	DT575	DT575
P3,E	none	none
P3,F	none	none
P4,A	DT530	none
P4,B	none	none
P4,C	none	none
P4,D	none	none
P4,E	DT579	DT579

(CE) List | Install | install All | Remove | iDent *>

The above mapping will cause a 'Map mismatch' alarm due to P4,A

Installing a Card

(CE) List | Install | install All | Remove | iDent >I

select port, card >P3,A

DT310 installed

(CE) List | Install | install All | Remove | iDent *>

Note: Installing a smart channel card in the equipment map will re-initialise the card.

Installing all Cards

```
(CE) List | Install | install All | Remove | iDent >A
P1,A, DT310 installed
P2,A, none installed
P3,A, DT310 installed
P3,B, none installed
P3,C, none installed
P3,D, DT575 installed
P3,E, none installed
P3,F, none installed
P4,A, none installed
P4,B, none installed
P4,C, none installed
P4,D, none installed
P4,E, DT579 installed
(CE) List | Install | install All | Remove | iDent *>
```

Removing a Card

```
(CE) List | Install | install All | Remove | iDent >R
select port, card >P3, A
DT310 removed
(CE) List | Install | install All | Remove | iDent *>
```

Identifying a Fitted Card

```
(CE) List | install All | Remove | iDent >D
select port, card >P3,A
map      Dual LIU - CEPT (DT986 Smart)
fitted   Dual LIU - CEPT (DT986 Smart)
(CE) List | Install | install All | Remove | iDent *>
```

5.4.18 Default Configuration

The default configuration is a configuration held in ROM which is available for the operator to load. To create a configuration it is necessary for the operator to either load an existing valid configuration or the default field. The operator can then modify the field to suit the required needs before saving it back into a configuration field.

The default configuration field has been set in the following manner:

- 1 P1 and P2 (Line 1 and Line 2)
 - Sync: Line loss
 - Fcode: FFH
 - Bypass: Disabled
 - Mode: Terminal
 - Error: 10^{-5}
 - CRC4: Disabled
 - Alarm: Line loss
 - Ts Assign: No timeslots allocated
- 2 Sync source
 - Failure recovery mode: Automatic
 - Automatic recovery delay: 1 second
 - Source selection: Freerun
- 3 Channel alarm events
 - All unassigned
 - Alarm events disabled
- 4 Circuit assignments
 - No timeslots assigned to channel cards.
 - TS control: 00000000B
- 5 Circuit controls
 - control 1: 11111011B
 - control 2: 11111111B
- 6 Smart configurations
 - All smart channel cards running config No. 1
- 7 Fcode table
 - All data: FFH
 - All signalling: FH
- 8 Cross connect channel assignment
 - All timeslots: Fixed data, Fcode 1

9 Management alarm events

All unassigned

Alarm events disabled

10 Route alarms

Route 1 Stream 1

Route 2 Stream 2

Route 3 Stream 3

Route 4 Stream 4

Route 5 P3 Circuit A1

Route 6 P3 Circuit A2

Route 7 P4 Circuit A1

Route 8 P4 Circuit A2

11 External relays

All disabled

5.5 Remote Menu

5.5.1 Operation (Non Network Mode)

Networking must be disabled in the 'Install' menu for this mode of operation. In this mode the multiplexer may use network management data paths for point to point control of the remote equipment.

In the example below the operator has selected 'Remote' to obtain a menu response from a 3400 (id G24) located remotely to the multiplexer. After this menu was received the operator entered the exit command, Ctrl +X, (not echoed) to return to the local multiplexer menu.

```
(P10) Maint | Fault | mOde | Configure | Time | Remote | Smart | closE >R
Control X to exit
(G24) Maint | Fault | mOde | Configure | Time | Remote | Smart | closE >
(P10) Maint | Fault | mOde | Configure | Time | Remote | Smart | closE >
```

5.5.2 Operation (Networking Mode)

When operated in network mode in conjunction with the NCS, this menu gives node to node control and messaging facilities.

```
(P10) Maint | Fault | mOde | Configure | Time | Remote | Smart | closE >R
(R) Control | List messages | Send message >C
Unit network no. >D01
NCU Responding:- Service granted
Control X to exit
(D01) Maintenance | Fault | mOde | Configure | Time | Remote | closE >
```

The operator now has control of equipment D01 via the Network Management System. Ctrl+X will restore control to the local unit.

Messages: One single line of text may be transmitted or displayed in message mode. The operator will be prompted for the unit identity to which it is required to send the message. Received messages can be viewed using the 'list' option. If a message has been received which has not been viewed the following will be displayed when remote is selected.

```
(R) Control | List (message awaiting) | Send message >
```

5.6 Smart Menu

Operation

The 'Smart' menu option at the root menu will provide the operator with access to any installed smart channel cards. On selection the operator will be prompted for a card slot identity, and control will then be passed to the menu system of the smart channel card installed in that position. The first menu displayed will be the Smart root menu. When at this menu the operator may press the 'ESCAPE' key to return to the main multiplexer menu.

Attempts to communicate with the card over the smart interface may fail due to the card initialising. An advisory message will inform the operator. This will only occur on power up or plug in of a smart card. This condition will not last for more than 1 minute.

In the example below the operator has selected the 'Smart' option and chosen to communicate with the card in slot A of Port 3.

The root menu of the card itself is then presented.

```
(P10) Maint | Fault | mOde | Configure | Time | Remote | Smart | closE >S
select port, card >P3,A
commencing communication with card type DT540
(S) Maint | Conf | Fault >
```

Control of the smart card will now follow the card menu structure as detailed in the appropriate smart card manual.

6

Fault Reporting & Maintenance Facilities

6.1 Fault Reporting

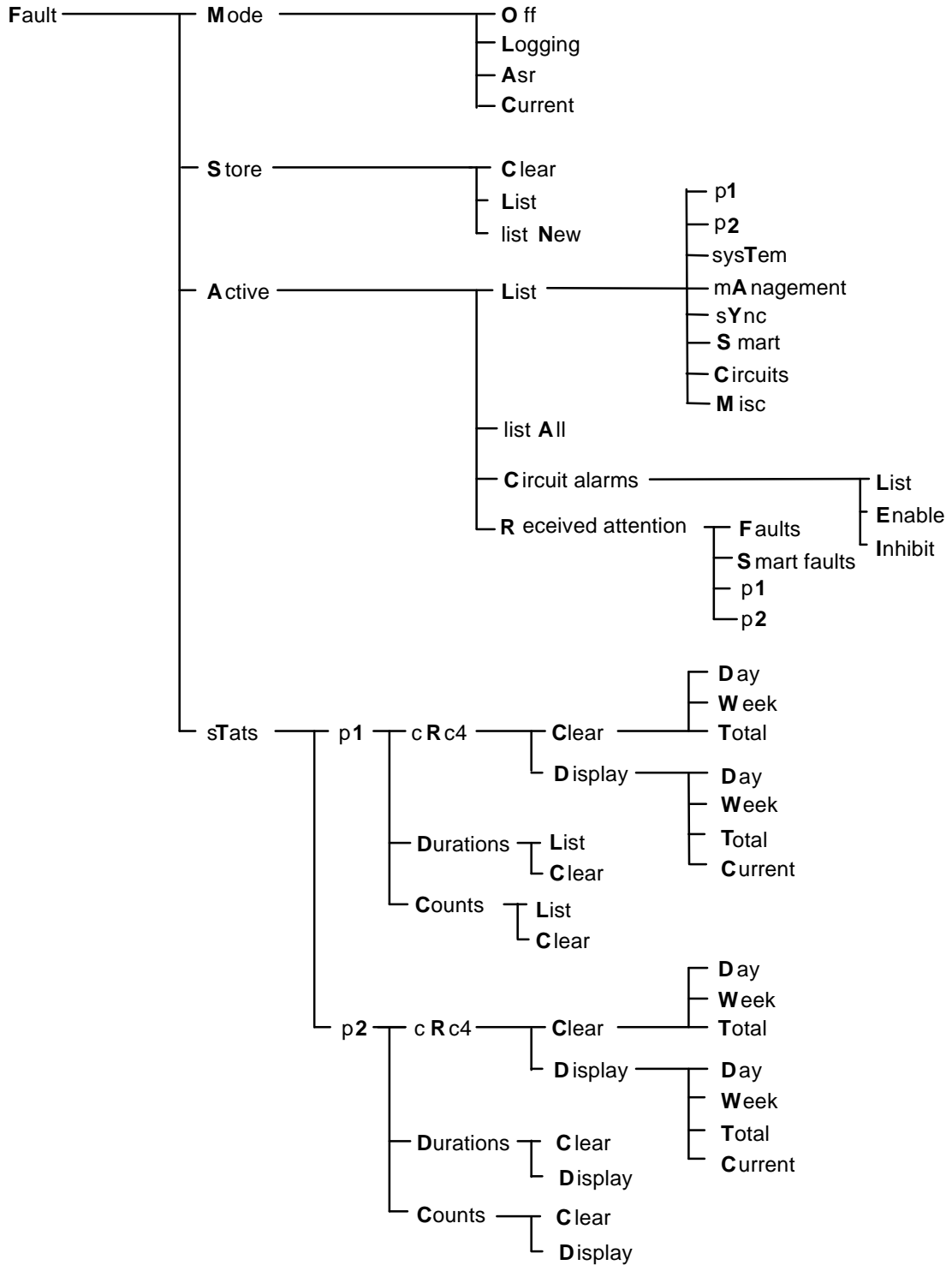

6.1.1 Fault Logging Modes

The operator can display or change the current fault reporting mode by menu selection:

'Off' - faults will be stored in the fault buffer.

'Logging' - faults will be logged to the screen as they occur as well as being stored.

'ASR' (Alarm Service Request)- An audible sound will be emitted from the terminal at one minute intervals as well as the faults being stored.

```
(F) Mode | Store | Active | sTats >M
(FM) Off | Logging | Asr | Current >C
current mode = 2 - Asr
(FM) Off | Logging | Asr | Current *>
```

6.1.2 Fault Store Listing and Clearance

The operator may 'List' all faults in the store, 'list New' faults since the last listing or 'Clear' the store completely. The fault store can hold up to 64 faults.

```
(F) Mode | Store | Active | sTats >S
(FS) Clear | List | list New >
```

6.1.3 Displaying Active Faults

The operator may list the active faults within any or all of the fault groups. The 'List' option will prompt for the required group whilst the 'list All' will display active faults within all groups except faults on cards not mapped in.

```
(F) Mode | Store | Active | sTats >A
(FA) List | list All | Circuit alarms | Received attention >L
(FAL) p1 | p2 | sysTem | mAnagement | sYnc | Smart | Circuits | Misc >
```

6.1.4 Inhibiting Circuit Alarms

The operator may modify each circuit to inhibit its alarm response and fault logging. To check which have been modified in this way, a list option provides a display of circuits that have been inhibited.

Note that if a circuit is set to alarm inhibit, then a single active fault will exist for that circuit indicating the mode set.

Inhibit

(FA) List | list **All** | **Circuit alarms** | **Received attention** >**C**
(FAC) List | **Enable** | **Inhibit** >**I**
port, circuit >P3,B4

List

(FA) List | list **All** | **Circuit alarms** | **Received attention** >**C**
(FAC) List | **Enable** | **Inhibit** >**L**
P3 circuit B4 alarm inhibited

Enable

(FA) List | list **All** | **Circuit alarms** | **Received attention** >**C**
(FAC) List | **Enable** | **Inhibit** >**E**
port, circuit >P3,B4

The alarm inhibit function derives information from the equipment map, and will warn the operator if an inhibit is attempted on a card that is not installed (Non-installed cards are not monitored for faults).

Installing or removing a card from the equipment map will clear any circuit inhibits set for that card.

6.1.5 Received Attention

Menu commands are available to enable the operator to clear the alarm relay response of any currently active faults. Active faults are marked with the 'Ocrd' (Occurred) status. When 'Received attention' is implemented this will change to 'RxAt'.

(FA) List | list **All** | **Circuit alarms** | **Received attention** >**R**
(FAR) **Faults** | **Smart faults** | p1 | p2 >

System faults may be marked received attention with the 'Faults' menu command.

(FAR) **Faults** | **Smart faults** | p1 | p2 >**F**
P63, 2 RxAt, 5 System , 9 Config 1 , , , TS , Time 18,6, 13, 28
P63, 2 RxAt, 9 Misc , 3 Map mismatch , , , TS , Time 21,4, 14, 32

(FAR) **Faults** | **Smart faults** | p1 | p2 *>

All faults which have received attention will be displayed.

Actioning this command will log a 'Rx.Attention Local' fault into the fault store.

Smart faults may be marked received attention with the 'Smart faults' menu command.

(FAR) **Faults | Smart faults | p1 | p2 >S**

select port, card >P3,A

P63, 2 RxAt, 6 Smart , 2 AIS 1 P3,A1, , , TS , Time 24,2, 10, 45

P63, 2 RxAt, 6 Smart , 37 Frame slip 2 P3,A2, , , TS , Time 24,2, 10, 51

(FAR) **Faults | Smart faults | p1 | p2 *>**

Port 1 or port 2 Dual LIU faults, which are also Group 6 Smart faults, may be marked 'Received attention' with the p1 or p2 menu commands.

6.1.6 Fault Tables & Alarm Responses

No.	FAULT	RELAYS			LEDS	ACTIONS					N O T	
		P	S	S Y		R	M	A	I	S		N
					A A S A G S S					E		
SYSTEM GROUP 5												
2	Power in fail	*	*	*							4	
3	PSU A fail		*		7						12	
4	PSU B fail		*		7						12	
5	PSU tolerance	*			7						12	
7	Event corruption	*	*	*	8						5	
8	Self test fail	*	*	*	8						6	
9	Config 1-14										0	1
23	Unconfigured	*	*	*	8	*	*		*	*	5	
24	Config self test				1						0	
25	Config 1-14 corrupt	*	*	*	8						5	2
39	RT clock corrupt	*	*		1						5	
40	System Restart	*	*	*	8	*	*		*	*	5	
41	Alarm event	*	*		1						10	
42	Main Fault		*		1						10	
43	Standby Fault		*		1						10	
44	LIU 1 fail	*	*	*	8	*	*		*	*	6	
45	LIU 2 fail	*	*	*	8	*	*		*	*	6	
46	Firmware Mismatch		*		1						10	
47	Main active										0	
48	Standby active										0	
49	Main Removed		*		1						10	
50	Standby removed		*		1						10	
51	Daughter board	*	*	*	8						5	
56	Offline Unconf		*								10	
SMART GROUP 6 LINE 1												
1	Line loss	*	*		2 3	*	*		*	*	7	3
2	AIS		*		2 3	*	*		*	*	8	3
3	F sync loss	*	*		2 3	*	*		*	*	9	
4	Filt err 10 ⁻³	*	*		2 3	*	*		*	*	9	3
5	Tslt 16 AIS		*		2 3		*		*		10	3
6	MF sync loss	*	*		2 3		*		*		10	3
7	MF Remote Alarm		*		2 3						16	3,9
8	Frame slip	*	*		2 3						10	3
9	Remote Alarm		*		2 3						16	3
10	Low err rate		*		2 3						15	3
13	Line O/P Fail	*	*		2 3						7	3
14	cRc reframe	*	*		2 3						9	
15	Local loop		*		2 3						12	
16	Incoming loop		*		2 3				*	*	12	
17	Circuit inhibit										0	

No.	FAULT	RELAYS			LEDS	ACTIONS						N O T E	
		P	S	S Y		R	M A I S T C	A	A	S	A		G
SMART GROUP 6 LINE 2													
32	Line loss	*	*		2 3	*	*		*	*		7	3
33	AIS		*		2 3	*	*		*	*		8	3
34	F sync loss	*	*		2 3	*	*		*	*		9	
35	Filt err 10 ⁻³	*	*		2 3	*	*		*	*		9	3
36	Tslt 16 AIS		*		2 3		*		*			10	3
37	MF sync loss	*	*		2 3		*		*			10	3
38	MF Remote Alarm		*		2 3				*			16	3,9
39	Frame slip	*	*		2 3							10	3
40	Remote alarm		*		2 3							16	3
41	Low err rate		*		2 3							15	3
44	Line O/P Fail	*	*		2 3							7	3
45	cRc reframe	*	*		2 3							9	
46	Local loop		*		2 3							12	
47	Incoming loop		*		2 3				*	*		12	
48	Circuit inhibit											0	
SMART GROUP 6 MISC													
31	System Restart	*	*	*	2 3							5	3
30	Unconfigured	*	*	*	2 3	*	*		*	*		5	3
25	Self Test Fail	*	*	*	2 3				*	*		6	3
23	Bypass		*		2 3				*	*		12	3
22	Clock Bypass		*		2 3				*	*		12	3
55	Path A selected											0	
54	Path B selected											0	
SYNC GROUP 7													
1	Not primary sync	*	*		6 8							7	
2	Sync 2 failed		*		1							14	
3	Sync 3 failed		*		1							14	
4	Sync 4 failed		*		1							14	
5	No sync source	*	*	*	1							14	
CIRCUIT GROUP 8													
1	Alarm 1	*	*	*	2 3 4 5 8							6	4
2	Alarm 2		*		2 3 4 5							11	4
3	Slip		*		2 3 4 5							12	4
4	Loop		*		1							15	
5	Alarm inhibit											0	

No.	FAULT	RELAYS			LEDS	ACTIONS					N O T	
		P	S	S Y S		R	M	A	I	S		N
MISC GROUP 9												
1	Timeslot loop		*		1						15	
3	Map mismatch		*		1						10	
5	Rx. Atten. local										0	
6	Rx. Atten. network										0	
7	Network fail		*		1						16	
9	Module ? Status ?		*		1						16	8
25	-48 battery fail		*		7						16	
26	Extern status 2		*		1						3	
27	Extern status 3		*		1						7	
28	Extern status 4		*		1						12	
29	Extern status 5		*		1						16	
30	Extern status 6		*		1						8	
	Self test	*	*		ALL						7	
MANAG GROUP 10												
1	Config 1-14										0	5
15	Unconfigured	*	*	*	1						5	
16	Config self test				1						0	
17	Config 1-14 corrupt	*	*	*	1						5	6
31	Alarm event	*	*		1						10	
32	Offline Unconf		*								10	

KEY:

RELAYS

P Prompt alarm.

S Service alarm.

SYS System alarm.

LEDS

1 Miscellaneous

2 Port 1 alarm

3 Port 2 alarm

4 Port 3 alarm

5 Port 4 alarm

6 Not primary sync source

7 PSU fault

8 System alarm

ACTIONS

RA Remote alarm sent.

MFA Multiframe alarm sent.

AIS Alarm Indication Signal sent.

16A Tslt 16 AIS sent.

SIG Signalling Fcodes set to MUX, FH on through timeslots.

TS Data Fcodes to MUX, FFH on through timeslots + TS0 spare bits to '1'.

NCS Network Management Alarm Level

Note 1

Group 5 fault 9 - configuration 1 running. Faults 10 to 22 correspond to configurations 2 to 14 running. One of the configurations will normally be running, and this zero level 'fault' is for information only.

Note 2

Group 5 fault 25 - configuration 1 corrupt. Similarly, faults 26 to 38 correspond to configurations 2 to 14.

Note 3

LIU faults from a board fitted to P1 will light LED 2, and not LED 3. LIU faults fitted to P2 will light LED 3 and not LED 2.

Note 4

Group 8 faults 1, 2 & 3 light either LED2, LED 3, LED 4 or LED 5 depending on the port. Fault 1 will also illuminate LED 8.

Note 5

Management configuration running 1 to 14 raise the corresponding zero level 'fault' numbers 1 to 14 for information only.

Note 6

Corrupt management configurations 1 to 14 raise fault numbers 17 to 30 respectively.

Note 7

Self test will set relays and LED indicators for a five second period.

Note 8

Group 9 faults 9 to 24 are:

9 = Module 1 status 1	17 = Module 1 status 3
10 = Module 2 status 1	18 = Module 2 status 3
11 = Module 3 status 1	19 = Module 3 status 3
12 = Module 4 status 1	20 = Module 4 status 3
13 = Module 1 status 2	21 = Module 1 status 4
14 = Module 2 status 2	22 = Module 2 status 4
15 = Module 3 status 2	23 = Module 3 status 4
16 = Module 4 status 2	24 = Module 4 status 4

Note 9

Signalling F codes are not set when in A/B mode.

6.1.7 Statistical Reports

Under the fault menu, the option is provided to display the results from the CRC4 checking facility if it has been enabled in the configuration set up (See 5.4.3. 6)), or to display the 'Counts' and 'Duration' of other LIU faults occurring on ports 1 and 2. Ports 3 and 4 do not have this facility

(F) **M**ode | **S**tore | **A**ctive | **s**Tats | **>**T

(F) p1 | p2 >1

(FT1) cRc4 | **D**urations | **C**ounts >

i) CRC4

The facility is provided to display or clear the CRC4 information. CRC tests are carried out over a 15 minute period after which a new check is started. Results are displayed for the following:

Errored Seconds

Severely Errored Seconds

Unavailable Time

CRC Count

CRC4 Errored seconds shall be counted as Severely errored seconds when the errored seconds exceeds a certain threshold. In the 3000 Series the severely errored second limit may be set in the Series 3000 multiplexer 'Mode Install' Menu. If PCM loss, or Service Loss persist for less than 10 seconds, then this will also be counted as severely errored seconds.

If severely errored seconds condition, PCM loss, or Service Loss persist for greater than 10 seconds, then this time will be counted as unavailable time.

The display can show the information for the following individually selectable periods.

- a) **Day:** This will be for the previous 24 hours and will show the total for each 15 minute count.
- b) **Week:** This will be the total on a daily basis for the previous seven days plus the status of the current check at the time of selection.
- c) **Total:** This will be the total since the CRC store was cleared.
- d) **Current:** This is an active display of the current check. If the display is left active it will start a new line for the next and subsequent 15 minute CRC checks

Note that on entry to the CRC4 menu that the escape key will be inhibited for a short period.

ii) Durations

This will give a display of the cumulative duration of faults which have occurred on either port or line. The counter increments in one second steps up to a maximum of 65535 seconds when the store will overflow and not reset. The store may be emptied using the 'Clear' command.

iii) Counts

This will give a display of the total number of times (events) that a fault has occurred in unit intervals up to a maximum of 255 when the store will overflow and not reset. The store may be emptied using the 'Clear' command.

6.2 Maintenance Facilities

The maintenance facilities are controlled by menu options as follows:-

Maintenance Menu

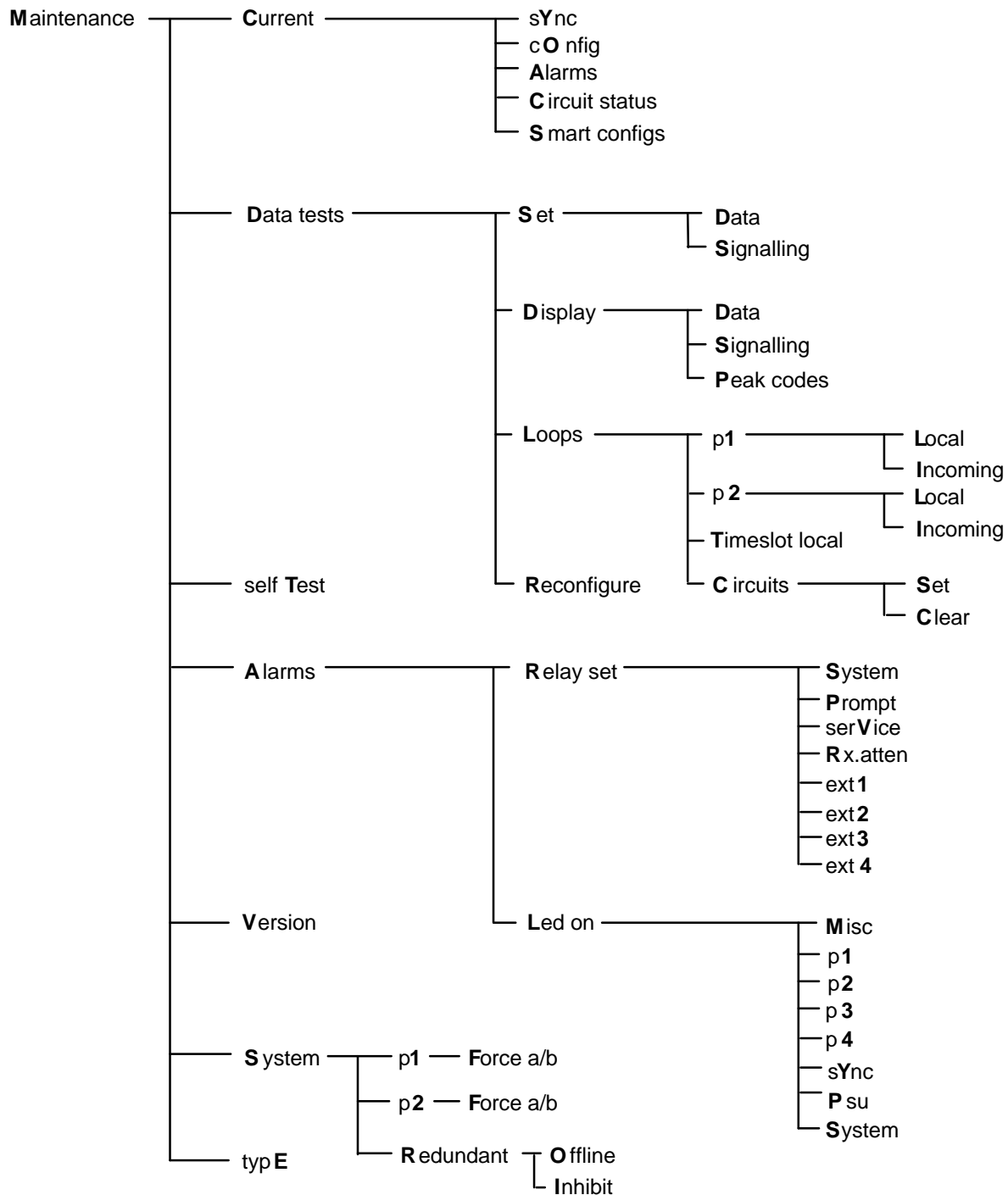

6.2.1 Current Status Monitoring

(M) **C**urrent | **D**ata tests | **s**elf **T**est | **A**larms | **V**ersion | **S**ystem | **t**yp**E** >**C**

The current status of the following items may be displayed by selection of the appropriate menu command.

Sync Source

This command displays the current sync source.

(MC) **s**Ync | **c**Onfig | **A**larms | **C**ircuit status | **S**mart configs >**Y**
priority 1 free running

Configuration

This command indicates the channel and management configurations that are currently running.

(MC) **s**Ync | **c**Onfig | **A**larms | **C**ircuit status | **S**mart configs >**O**
current channel configuration is 4
current management configuration is 1

Alarm Status

This command indicates the current status of all LEDs and alarm relays.
0=inactive alarm, 1=active alarm.

(MC) **s**Ync | **c**Onfig. | **A**larms | **C**ircuit status | **S**mart configs >**A**

System	RLY = 0	Misc	LED = 0
Prompt	RLY = 1	Port 1	LED = 1
Service	RLY = 1	Port 2	LED = 0
Receive Atten	RLY = 0	Port 3	LED = 0
Ext. Control 1	RLY = 1	Port 4	LED = 0
Ext. Control 2	RLY = 0	Sync	LED = 0
Ext. Control 3	RLY = 0	PSU	LED = 0
Ext. Control 4	RLY = 0	System	LED = 0

Circuit Status

This menu command requests a port followed by the circuit range, and then displays any timeslot assignments followed by the status port values for the range specified.

```
(MC) sYnc | cOnfig | Alarms | Circuit status | Smart configs >C  
port, first, last cct >P3,A1,A4
```

```
port (P3, A1,TS 4)   status 1 11011111B,   status 2 10011111B  
port (P3, A2,TS 5)   status 1 11111111B,   status 2 10111111B  
port (P3, A3,TS  )   status 1 11111101B,   status 2 11011111B  
port (P3, A4,TS 7)   status 1 10111111B,   status 2 11011111B
```

Refer to the relevant interface card Reference manual for the interpretation of status port byte information.

Smart Channel Card Configuration Storage

The operator may list the current storage in use for smart channel card configurations. A Smart card may have up to 4 configurations, but if any are the same these will only count as 1 config. Dual LIU cards in ports 1 and 2 will have 14 integrated configurations.

```
(MC) sYnc | cOnfig | Alarms | Circuit status | Smart configs >S  
remaining storage = 86%  
P1 position A DT310 allocated 14 configs.  
P4 position A DT580 allocated 2 configs.
```

6.2.2 Setting Data and Signalling

```
(M) Current | Data tests | self Test | Alarms | Version | System | typE >D
```

The timeslot data and signalling can be set on the outgoing timeslots of all streams and ports from the cross-connect awitch. Data may be set in binary, decimal or hexadecimal with suffix B,D or H added as appropriate. If the suffix is omitted decimal will be assumed.

```
(MD) Set | Display | Loops | Reconfigure >S  
(MDS) Data | Signalling >D  
stream, timeslot, data >P3,1,70H
```

6.2.3 Displaying Data, Signalling and Peak Codes

Data and Signalling

The 'Data' 'Display' commands allow the operator to monitor the data in a timeslot or the signalling data in TS16 associated with a timeslot from any of the incoming streams or ports. Data and signalling will always be displayed in Hexadecimal.

```
(MDD) Data | Signalling | Peak codes >D
stream, timeslot >S2,7
70H,***,70H,
```

Note: while timeslot data is changing '***' will be displayed and '**' while signalling data is changing.

The monitor points for all 'Set' and 'Display' data are shown in Figure 6-1.

Peak Codes

This command allows the peak codes for G.711 'A law' encoded speech to be displayed. The estimated peak power level is also displayed with a resolution of 1dB. The power displayed assumes a sinusoidal signal is present.

```
(MDD) Data | Signalling | Peak codes >P
stream, timeslot >P3,19
levels (G711) power
min,      max    dBm0
-118 ,    +118,    0
-118 ,    +118,    0
```

6.2.4 Loops - Setting and Clearing

Commands are provided to allow loops to be set and cleared.

P1 or P2 may be selected for 'Local' and 'Incoming' PCM stream loops.

Timeslot local and Circuit loops will prompt for a stream or port selection as well as the timeslot or circuit to be looped.

Positions for all loops are shown in Figure 6-1.

Note: Incoming and Local PCM loops reset each other, each cannot therefore be set at the same time. Both incoming and local loops require an additional parameter that specifies the period for which the loop is to be applied. This may be from 1 to 120 seconds, indefinite if 'I' is entered or 10 seconds if no parameter is entered. The positions of all loops are shown in Figure 6-1.

Local Loops

This commands the Dual LIU to apply a local PCM loop back to the required stream at the G.703 interface. The outgoing line signal for the selected stream will contain AIS. Note that while the loop is applied any management data paths carried over the stream will be lost, therefore care must be taken when applying loops with NCS. Line faults will not be monitored while this loop is active. A local loop on the active path of a Dual LIU with A/B switching enabled will not cause a change over to the other path.

```
(MD) Set | Display | Loops | Reconfigure >L
(MDL) p1 | p2 | Timeslot local | Circuits >1
(MDL1) Local | Incoming >L
(MDL1L) line 1 | line 2 >1
warning - Recovered clock on stream will be invalid
duration (1..255 seconds) >60
(MDL1L) line 1 | line 2 *>
```

In the above example a loop has been applied for 60 seconds.

Incoming Loop

This commands the Dual LIU to apply an incoming PCM loop back to the required stream at the G.703 interface. While the loop is applied any management data paths carried over the stream will be lost, therefore care must be take when applying loops with NCS. Note that when an incoming loop has been set and the input line fails, the 'line O/P' fault will be active.

```
(MD) Set | Display | Loops | Reconfigure >L
(MDL) p1 | p2 | Timeslot local | Circuits >1
(MDL1) Local | Incoming >I
(MDL1I) line 1 | line 2 >1
duration (1..255 seconds) >60
(MDL1I) line 1 | line 2 *>
```

In the above example an incoming loop has been applied for 60 seconds.

Timeslot local loop

This commands the system controller to loop a selected timeslot back to its source via the cross connect switch.

(MD) **S**et | **D**isplay | **L**oops | **R**econfigure >**L**

(MDL) **L**ocal | **I**ncoming | **T**imeslot local | **C**ircuits >**T**
stream, timeslot >P3,1

When applying a timeslot local loop all data sourced from the looped timeslot will be forced to fault codes. For Nx64k circuits, all timeslots must be looped individually.

Circuit Loop

This command instructs channel cards supporting circuit loops to activate or clear the loop. For details of loops provided on individual channel cards, refer to the channel card operating manual for details. Individual circuit loops may be set and cleared.

(MD) **S**et | **D**isplay | **L**oops | **R**econfigure >**L**

(MDL) **L**ocal | **I**ncoming | **T**imeslot local | **C**ircuits >**C**

(MDLC) **S**et | **C**lear >**S**

port, circuit >P3,A2

(MDLC) **S**et | **C**lear *>

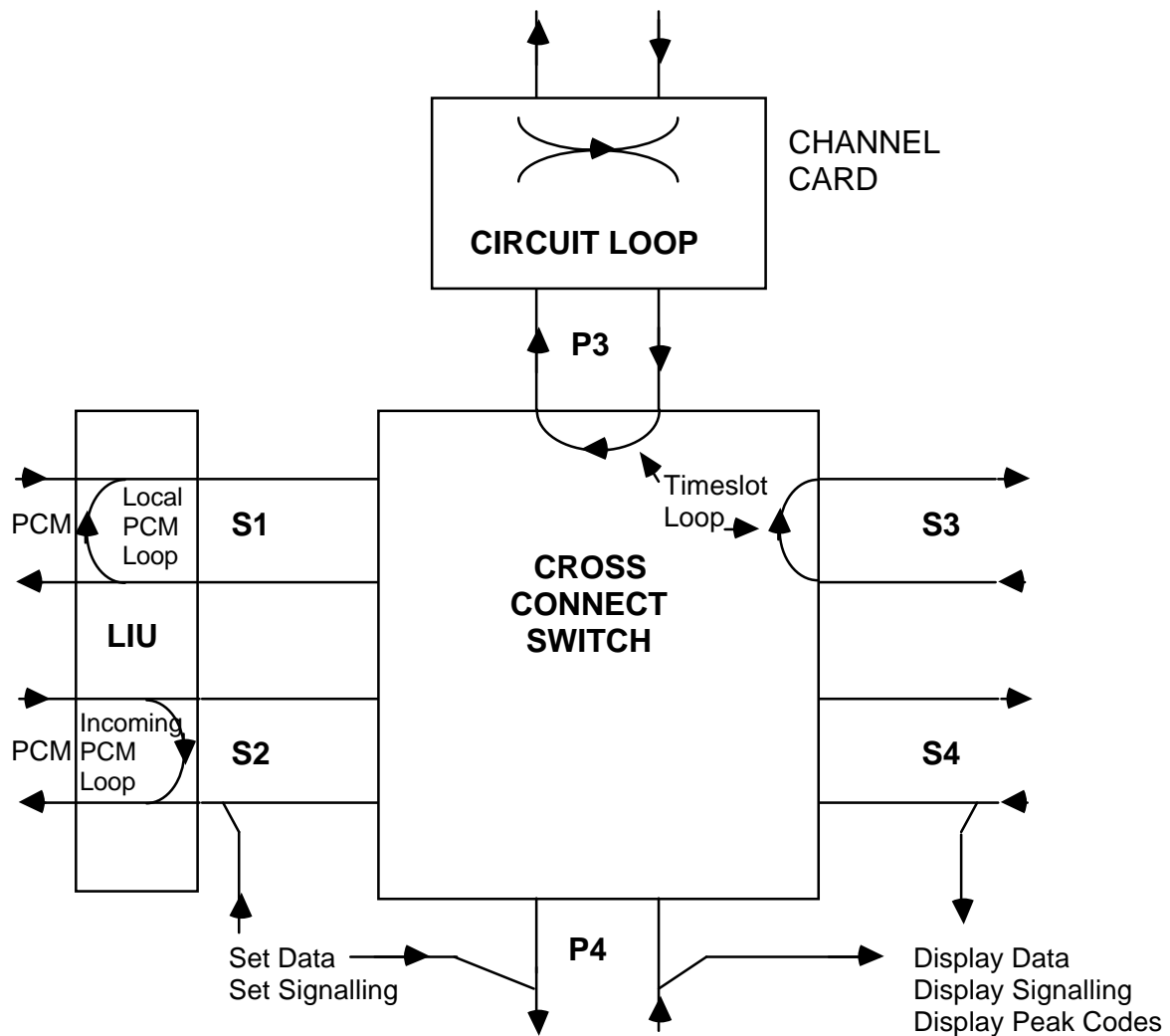

Figure 6-1 Position of Loops and Data Test Points

Reconfigure

The 'Reconfigure' option runs the current configuration again. All loops and data tests will be cleared, and in A/B mode 'path A' will be selected.

(MD) **Set** | **Display** | **Loops** | **Reconfigure** >R

6.2.5 Running Self Test

Commands are provided to initiate a 10 second (approx) self test. See Section 2.3.3 for details of the test.

Self Test Menu

Example 1 - Self Test Passed

(M) **C**urrent | **D**ata tests | **s**elf **T**est | **A**larms | **V**ersion | **S**ystem | **t**yp**E** >T
 are you sure (Yes | No) >Y
 self test passed

Example 2 - Self Test Failed

```
(M) Current | Data tests | self Test | Alarms | Version | System | type >T  
are you sure (Yes | No) >Y  
self test failed
```

If the self test fails, there will be diagnostic information presented to the operator after the self test failed message. This will list the faults and show the total number of items that have failed. An active fault 'Self test fail' will be raised, and it will be necessary to carry out a satisfactory self test to clear it.

If two system controllers are present, only the on-line system controller will perform its self test.

6.2.6 Alarm Relay Setting and Clearing

Setting

The 'Relay set' command allows the operator to set the condition of any of the 3200 alarm and external relays. If they are already set active due to any faults or configuration commands they can still be disabled. Once set, either enabled or disabled, the relay will remain in that condition until the operator leaves the relay selection menu when it will automatically be reset to its current true state.

```
(M) Current | Data tests | self Test | Alarms | Version | System | type >A  
(MA) Relay set | Led on >R  
System | Prompt | serVice | Rx.atten. | ext1 | ext2 | ext3 | ext4 >1  
ext1 Enabled (0=disable 1=enable) >0
```

This selection would have disabled the 'external control relay 1' (ext1) even though it was in the active state due to a current configuration command as described in section 5.4.5.3.

6.2.7 System LED Test

This command allows the operator to illuminate any of the system controller LEDs. If they are already active then this command will have no effect. Once illuminated, the LEDs will remain in that condition for a short time after the operator leaves the LED selection menu.

```
(M) Current | Data tests | self Test | Alarms | Version | System | type >A  
(MA) Relay set | Led on >L  
(MAL) Misc | p1 | p2 | p3 | p4 | sYnc | Psu | System >Y
```

This selection would illuminate the 'not primary sync' LED if not already lit.

6.2.8 Equipment Type and Version Display

Equipment Version

This command displays the software version information for the system controller. This is presented as the product code followed by the build level.

```
(M) Current | Data tests | self Test | Alarms | Version | System | typE >V  
Main Card  
DT981/6  
Standby Card  
DT981/6 (only displayed if fitted)
```

Equipment Type

This command displays the equipment type code used for the network management system.

```
(M) Current | Data tests | self Test | Alarms | Version | System | typE >E  
3000/3
```

In this case the 3200 must be installed as a 3000/3 node in the network management system for the correct menus and faults to be displayed on the controller. This will require the correct network management 'Application module' to be installed in the manager.

6.2.9 Manual A/B switching

A command 'Force a/b' is available which will only be relevant in the A/B mode of operation. When this command is used, the currently active line will become inactive and the inactive line will become active. If the change-over occurs from a good line to a bad line, the card will automatically change back after the hold delay period has expired. The current position of the switch is displayed in the active fault log.

```
(M) Current | Data tests | self Test | Alarms | Version | System | typE >S  
(MS) p1 | p2 | Redundant >1  
(MS1) Force a/b >F  
(MS1) Force a/b *>
```

The above action would have caused the Dual LIU fitted in port 1 to change-over from one input to the other.

6.3 Network Problems

All networks will occasionally show problems. These may be indicated by one or more of the following:

- a) Alarm relays operating.
- b) Alarm indicators lighting.
- c) Alarm messages displayed if fault logging is on.
- d) Communication problems through the network.

Problems can be caused by any one or more of the following:

- a) Power loss at a node.
- b) PCM transmission problems.
- c) Synchronisation problems.
- d) Incorrect equipment configurations.
- e) Equipment faults.

The 3200 contains comprehensive fault tracing facilities to enable operators to determine, and rectify, the cause of any network faults. When a fault occurs, or clears, a message is added to the fault message store, and displayed if fault logging is on. This can be used for detecting faults as they occur and is useful for checking intermittent faults. This facility must be used with caution as the fault message store has a limited capacity. If a main fault occurs, say primary sync source loss, this could cause frequent PCM frame slips to occur. The messages for these would rapidly fill and overflow the message store. Listing the store would then only list frame slips. The cause of the problem, primary sync loss, would not be listed. The most important fault tracing facility is the 'Fault'- 'Active' sub-menu, on the multiplexer and smart channel cards. This allows listing of the presently active faults, or optionally active faults separated into several fault groups. In the above example the primary clock loss would be listed under the Sync fault group.

Another facility which is useful during fault checking is the 'Maintenance'- 'Current' command. This allows listing of the current sync source, configuration and other data.

The interrelation between the four main fault classes is shown below.

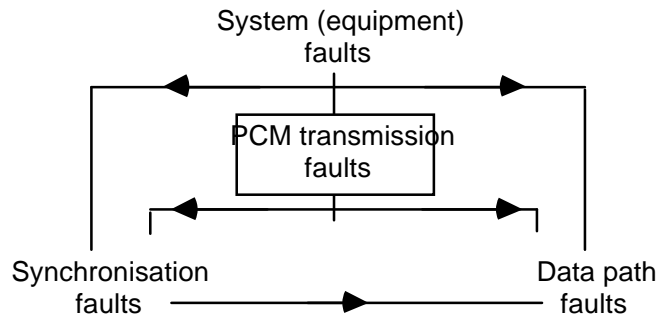

From this it can be seen that the correct sequence for clearing network problems is:

1. Check and clear all system faults at all nodes in the network.
2. Check and clear all PCM transmission faults in the network. Note that where a transmission fault could be caused by either a PCM equipment or by the transmission link, application of test loops can deduce the area of fault. Test loops can be applied by either using test facilities built-into equipments, or by using external cable connections to loop the PCM paths.
3. Check and clear all synchronisation faults.
4. Check data path routing and data circuit connections. Circuit test loops can be configured to assist in the testing of the external data connections and data synchronisation.

6.4 Built-in Test Facilities

The multiplexer built-in test facilities are accessed via the Maintenance sub-menu. In each section below the numbers in brackets are the manual section numbers to refer to for details of the command.

Installation/System Faults

To permit testing of the external alarm relay circuit each relay can be set or cleared using the Maintenance - Alarm - Relay Set commands (6.2.6). The Maintenance - Alarm sub-menu also allows control of the system controller LEDs. When testing is completed relays and indicators will be automatically reset to the correct current status.

The self-test routine, which is automatically carried out after a cold start-up, may be restarted by use of the Maintenance-self-Test command (6.2.5).

WARNING: The node will be isolated from the network during the period of self test

PCM Faults

PCM loops may be applied to Dual LIUs in ports 1 and 2 by use of the Maintenance - Data tests - Loops - menu (6.2.4). Both Local and Incoming PCM loops may be set to each G.703 line signal. On completion of testing, LIU loops if set to indefinite must be removed by use of the 'Reconfigure' command. If an LIU is operated in an asynchronous system, frame slip indications will occur.

Synchronisation Faults

Synchronisation faults are caused by failure of synchronisation sources. For recovered clocks the failure conditions can be selected under the sync configuration set up (5.4.3). Depending upon the option selected, failure can be caused by PCM loss, service loss or receipt of an incoming frame alarm. For the G.703 clock inputs failure occurs on signal loss. All clock sources in the sync source selection list are also monitored for frequency tolerance. If the frequency is outside the limits the source is classed as failed.

Data Path Faults

Data signals through the multiplexer can be monitored by use of the Maintenance - Data - Display sub-menu commands. The Data command (6.2.3) periodically samples the data in the selected incoming timeslot. If the data is not changing the data value is displayed as a hex code. If the data is changing, or changes after display of a hex code, three asterisks will be displayed. If the data subsequently settles to a constant value it will again display the hex code. This will repeat until the Esc key is operated.

A constant data code may be inserted into an outgoing timeslot by use of the Maintenance - Set Data commands (6.2.2).

The Peak codes command is used for checking channels carrying VF signals. This monitors the data in a selected incoming timeslot for a 5 second period. It then displays the maximum and minimum A-law values, and approximate power levels. This repeats until the Esc key is operated.

6.5 NCS Fault Levels

Level 1 Faults

There are no faults at this level.

Level 2 Faults

There are no faults at this level.

Level 3 Faults

External status 2

This indicates the presence of an alarm condition on external status line 2.

Level 4 Faults

Power in failure

This fault indicates that a power fail condition has occurred.

Level 5 Faults

Event corruption

This fault indicates that the timed event store within the node is corrupt. The most likely cause of this is the battery used for data retention has discharged. The events within the store must be corrected for this fault to clear.

Unconfigured

This fault indicates that the default configuration is running within the node. This will occur if at power up the unit cannot determine the correct configuration to run. The unconfigured fault can occur for Management, PCM channel and Smart configurations.

Config 1 corrupt

This fault indicates that the background check routine has found this configuration data corrupt. Ram corruption may occur if the battery utilised for the retention of data has discharged. The configuration corrupt fault can exist for PCM channel, Management and Smart configurations.

Config 2 corrupt to config 14 corrupt

As config 1 corrupt

RT Clock corrupt

This fault indicates that the data from the real time clock is corrupt. The most likely causes of this problem are that it has never been correctly configured or the battery is discharged.

System restart

This fault indicates that the unit has failed to undertake normal software operation. This will cause a restart fault to occur. The self test routine will not be entered after a system restart.

Level 6 Faults

Self test failed

This fault indicates that the unit has failed self test. This fault will clear once the self test has been run successfully.

LIU 1 fail

This fault occurs if a Dual LIU fitted in port 1 fails.

LIU 2 fail

This fault occurs if Dual LIU fitted in port 2 fails.

Alarm 1

This fault indicates that one of the channel cards has a fault associated with it. Usually Alarm 1 is associated with channel card failure.

Level 7 Faults

External status 3

This indicates the presence of an alarm condition on external status line 3.

Line loss

This fault indicates that line signal loss has occurred.

Not Primary sync

This fault indicates that the primary synchronisation signal has been lost.

Comms failure

This fault is used to indicate that the smart communication link between the system controller and smart channel card has failed. This will mean that none of the configurations running on the smart channel cards can be considered to be valid, and the card should be re-initialised until the fault clears.

Line O/P Fail

This fault occurs when the Mux detects that there is no output from the specified output on a Dual LIU card.

Level 8 Faults

External status 6

This indicates the presence of an alarm condition on external status line 6.

AIS

This indicates that the AIS signal has been detected on the specified line I/P of a Dual LIU.

Level 9 Faults

F sync loss

This fault indicates that the framing pattern of TS0 cannot be detected on the specified line I/P of a Dual LIU.

Filt err 10E3

This fault indicates that an error rate of 1 in 10^3 or greater has been detected in the TS0 frame synchronisation word over a period of five seconds.

CRC Reframe

This fault only occurs when CRC is enabled and the relevant Dual LIU has detected errors exceeding 914 in 1 second, at which point the relevant line will be forced to search for a new CRC Frame signal.

Level 10 Faults

Frame slip

Frame slips will occur if there is a problem with the synchronisation of the equipment. The slip is an attempt to re-sync to the Frame alignment pattern. This will result in the omission or repeat of one frame of data.

Tslt 16 AIS

This fault indicates that the AIS signal, i.e. all 1's has been detected in TS16.

MF sync loss

This fault indicates that the multiframe synchronisation pattern has not been detected when the line is set to CAS mode. It is possible that the incoming line signal is in CCS signalling mode.

Alarm event

This fault indicates that an alarm event has occurred i.e. an automatic configuration change due to a fault. This fault can be cleared by manually running a configuration.

Circuit Inhibit

Indicates that faults from the relevant circuit have been inhibited.

Map Mismatch

This fault indicates that there is an incorrect channel card fitted in the chassis, or that no card is fitted where one is expected i.e. mapped in.

Level 11 Faults

Alarm 2

The alarm 2 fault is used to signify a channel card fault. Alarm 2 faults are usually associated with operational faults (e.g. line signal loss).

Level 12 Faults

PSU A Fail

This indicates that power supply unit 'A' has failed, when 'fitted' in the 'mOde-Install' menu.

PSU B Fail

This indicates that power supply unit 'B' has failed, when 'fitted' in the 'mOde-Install' menu.

PSU tolerance

This fault indicates that one of the internal power supply rails is outside the specified tolerance of $\pm 4\%$.

Slip

This fault is associated with a channel card and is present when a data circuit slip has occurred on the card. It is usually caused by incorrect clocking.

Local loop

This fault indicates that a local PCM loop has been set on the line.

Incoming loop

This fault indicates that an incoming PCM loop has been set on the line.

Bypass

This fault occurs when the relevant Dual LIU is in PCM bypass.

Clock Bypass

This fault occurs when the relevant Dual LIU is in Clock bypass.

External status 4

This indicates the presence of an alarm condition on external status line 4.

Level 13 Faults

There are no faults at this level.

Level 14 Faults

Sync priority 2

This fault indicates that the second synchronisation source has failed.

Sync priority 3

This fault indicates that the third synchronisation source has failed.

Sync priority 4

This fault indicates that the fourth synchronisation source has failed.

No Sync source

This fault indicates that all the clock selections given in the channel configuration have failed and the system is now running priority 5 source (free run).

Level 15 Faults

Low err rate

This fault will indicate that an error rate greater than the assigned threshold has been detected.

Timeslot loop

This fault indicates that the operator has set a loop on certain timeslots.

Circuit Loop

This fault indicates that a circuit loop has been set on a channel card.

Level 16 Faults

MF Remote Alarm

This fault indicates that a multiframe alarm has been received from a remote equipment.

Remote alarm

This fault indicates that a frame alarm has been received from a remote equipment.

Module 1 Status 1

This fault indicates that module 1 has raised status line 1. For optical interface modules this is electrical line signal loss.

Module 1 Status 2

This fault indicates that module 1 has raised status line 2. For optical interface modules this is optical line signal loss.

Module 1 Status 3

This fault indicates that module 1 has raised status line 3.

Module 1 Status 4

This fault indicates that module 1 has raised status line 4.

Module 2 Status 1 to Module 2, 3 and 4.

Faults are the same as module 1 for modules 2, 3 and 4.

-48V battery fail

When enabled by the installation set-up command, this fault will indicate that the -48VDC feed to the multiplexer backplane has failed.

External status 5

This indicates the presence of an alarm condition on external status line 5.

Level 0 Faults (Information)

Config 1 (PCM channel and Management)

This fault indicates that configuration 1 is currently active.

Config 2 - 14

As for Config 1 above.

Config self test (PCM channel and Management)

This fault indicates that the self test configuration is currently active. This can be initiated from two possible sources.

- 1) The unit has just been powered up
- 2) The maintenance self test command has been activated

Rx. Atten. Local

The currently active faults have had their relay driving actions inhibited by the use of the local receive attention command. This command will originate from the operator menu under the 'faults active' section.

Rx. Atten. Network

The currently active faults have had their relay driving actions (when enabled on the node) inhibited by the use of the network receive attention command. This command will originate from the network control unit.

Path A Selected

This fault indicates that Line 1 is active in A/B mode.

Path B Selected

This fault indicates that Line 2 is active in A/B mode.

Circuit Inhibit

Indicates that faults from the relevant circuit have been inhibited.

Alarm Inhibit

This fault indicates that the circuit number given in the fault report has had all its faults inhibited.

7.1 General Information

A copy of the manual supplied with each channel card type should be inserted in this chapter using the dividers provided.

Channel Interface Cards may be fitted into any position as indicated in this manual. The channel card manual describes the facilities available on each interface along with configuration and connection detail.

All channels cards may be inserted or removed from the 3200 with power applied to the chassis without damage. It is usual to remove the card from the Equipment map before physical removal to prevent an alarm being raised.

Configuration of a channel card consists of:

- a) Hardware configuration by links or DIL switches.
- b) Soft configuration by means of Control Ports and a TS Control port.
- c) Smart cards configured by menu options.

Two 'Control ports' in the form of two bytes of information are provided for each circuit on each channel card (on some cards only one is used), and these are used to configure the card from the control terminal. The setting of the bits for these control bytes is described for each card in the relevant manual for the card type.

Voice Frequency (VF) cards require an additional byte of information called the 'TS Control'. This byte of information is used to set the analogue interface VF levels and is programmed at the same time as the timeslot is assigned to the circuit. This parameter should be ignored when assigning timeslots to data cards.

Each channel card has two 'Status ports' in the form of two bytes of information which are available in the 'Maintenance' menu to provide the operator with some information regarding the current operation of the card.

A unique I.D. code for the card is contained in the status port information which is used by the system controller in the 'Equipment map' to display which type of card is fitted in each position.

Data channel cards, when set for DTE operation, can provide an 8kHz clock signal derived from the data/clock input at the interface. This can be selected by links or switches to drive the 8k1 or 8k2 signals for use as the source of system synchronisation. Only one circuit in the multiplexer must be set to provide each clock.

All channel cards have their channel interface connections on the upper backplane connector. The connections are listed in the relevant channel card manual. A Universal I/O Adapter DT280 is available to convert the 96 way DIN connector to a 50 way Amphenol female connector. This adaptor provides additional screening and must be used where compliance to EMC specifications is required. Converter cables to change the Amphenol connector to a standard data interface for the type of card is also available.

The maximum power required by any of the channel cards (not using the backplane -48V supply) is 8W, however the power requirement for most of the cards is considerably less than this. The maximum loading for each card can be found in the relevant channel card manual.

A red LED provided on all data cards (one per circuit) gives a visual indication that the circuit is in loop or that, in DTE mode, a timing slip is occurring. On cards with more than one circuit the lower LED is for circuit 1. Other LED functions are described in the manual for each card.

The relationship of input/output connections for all interface cards is shown below.

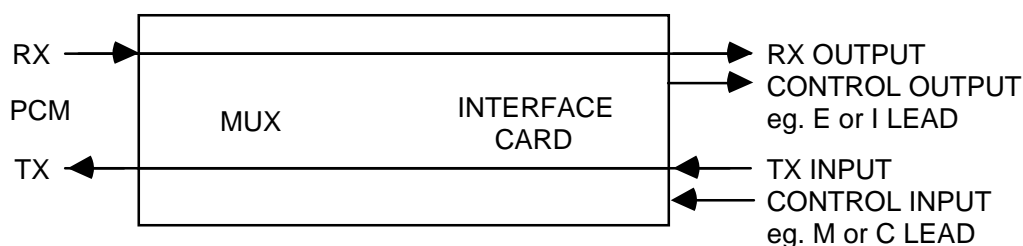

7.2 Approvals

The following Interface cards, when fitted to a 3200 multiplexer chassis, have approval for use with 'Private Circuits' Details of the approvals are given in the relevant installation and operation manual for each card.

Quad 2/4 Wire E&M Channel Card	DTE65 & 69
Quad 4 Wire AC Signalling Card	DTE66
Eight Channel ADPCM Card	DTE90 to 94 inclusive
Dual V.11 Universal Data Card	DTE50
Dual 2048k Line Interface Card	DTE240 & 241
G.703 2Mbit/s Optical Modules	DT504 to 509 inclusive
Dual Nx64k Data Card	DT585

7.3 Interface Card Reference Numbers

Quad 2/4 Wire E+M Card	DTE65 & 69
Quad 4 Wire AC Signalling Card	DTE66
Quad 2 Wire Loop Disconnect (Exch) Card	DTE63
Quad 2 Wire Loop Disconnect (Subs) Card	DTE59, 64 & 83
4/8 Channel 2 Wire Loop Disconnect (Subs) Card	DTE67 & 68
Ringling Generator Card	DT579
E&M Signalling Card	DTE62
Eight Channel VF/ADPCM Card	DTE90 to 95 inclusive
Delay Compensation Card	DT517
Dual Universal Data Card (DT500) fitted with:	
a) V.11 Module	DTE50
b) V.35 Module	DTE51
c) V.36 Module	DTE58
d) G703 Co-Directional Module	DTE53
e) G703 Contra-Directional Module	DTE54
f) DDS Network V.11 & V.35 Operation	DTE55 & 56
g) 12kbit/s V.35 Operation	DTE57
Quad 64k X.21 (V.11) Data Card	DT587
Quad 64k V.35 Data Card	DT561
Quad G.703 Contra-Directional Data Card	DT521
Quad G.703 Co-Directional Data Card	DT536
Nx64k RS-449 (V.11 and V.35) Data Card	DT530
Dual Nx64k (V.11) Data Card	DT585
64k Sub Multiplex Card	DTE85
64k Dual V.24 Multipoint Card	DTE87
8 Channel V.110 Data Card	DTE82
DC5/Loop Disconnect Signalling Converter Card	DTE80 & 81
1544k Line Interface Card	DTE74 & 75
Optical 2 Mbit/s G.703 Modules	DT504 to 509 inclusive
Dual 2048k Line Interface Unit	DTE241
TS0 Data Compression Card	DTE243
Transmic 2G System Card	DTE242

A

Patchfield Electrical Diagrams

A.1 General Information

Patchfields for the system controller and Dual LIU Cards are pre-programmed and held in PAL devices. The patchfield devices are allocated a DT number which is marked on the device.

The following electrical equivalent diagrams refer to patchfields DT990/C for the System Controller and DT995D for the Dual LIU Card.

Each patchfield can hold up to 8 patchfields, however only 1 to 7 should be selected by the operator. Patchfield 8, not shown, in all cases is for test purposes in manufacturing and must *not* be selected.

As an aid to determining a complete electrical picture for the Dual LIU management routing when using different patchfields for line 1 and line 2, it is suggested that separate copies be made of line 1 and line 2 patchfields, these can then be mated together to show for example line 1 patchfield 4 with line 2 patchfield 6.

If a line on a Dual LIU card is not used for carrying management, the patchfield for that line should be patchfield number 1.

System Controller Electrical Patchfield Diagrams DT990/C

Patchfield No. 1

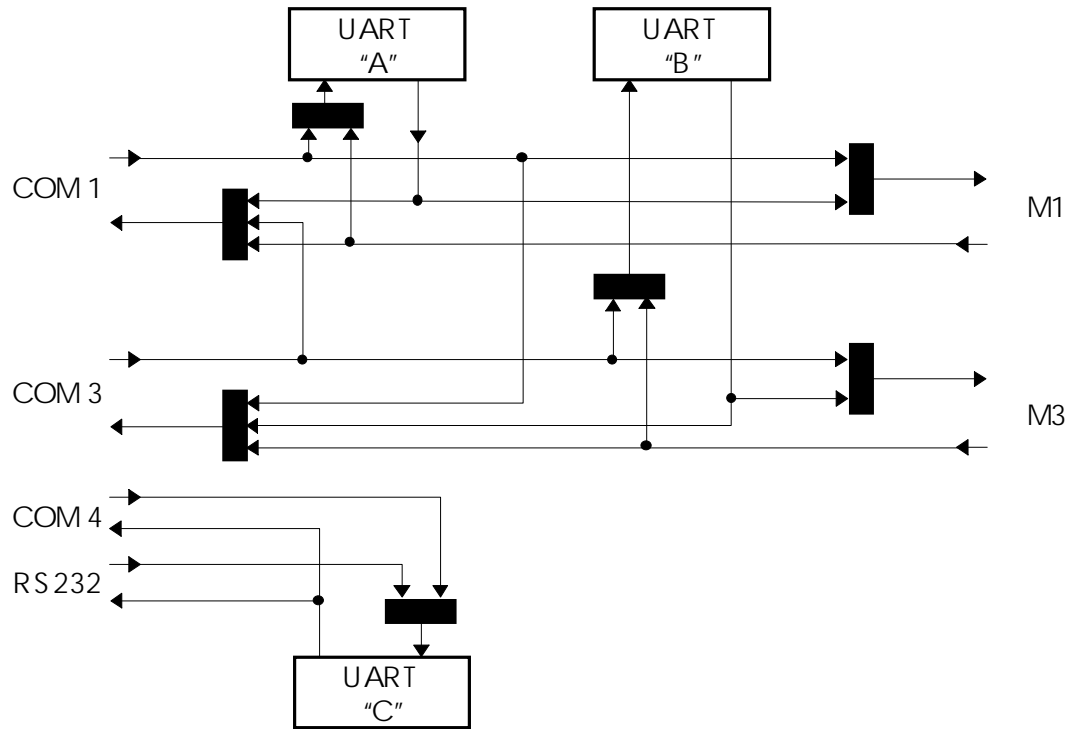

Patchfield No. 2

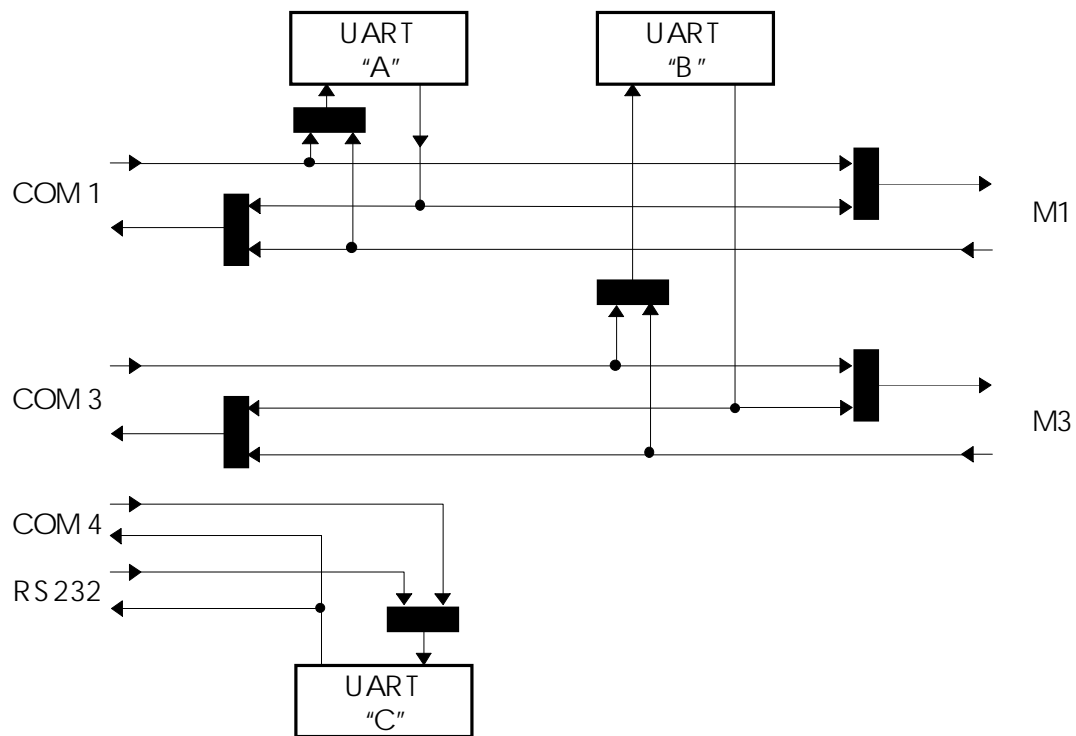

Patchfield No. 3

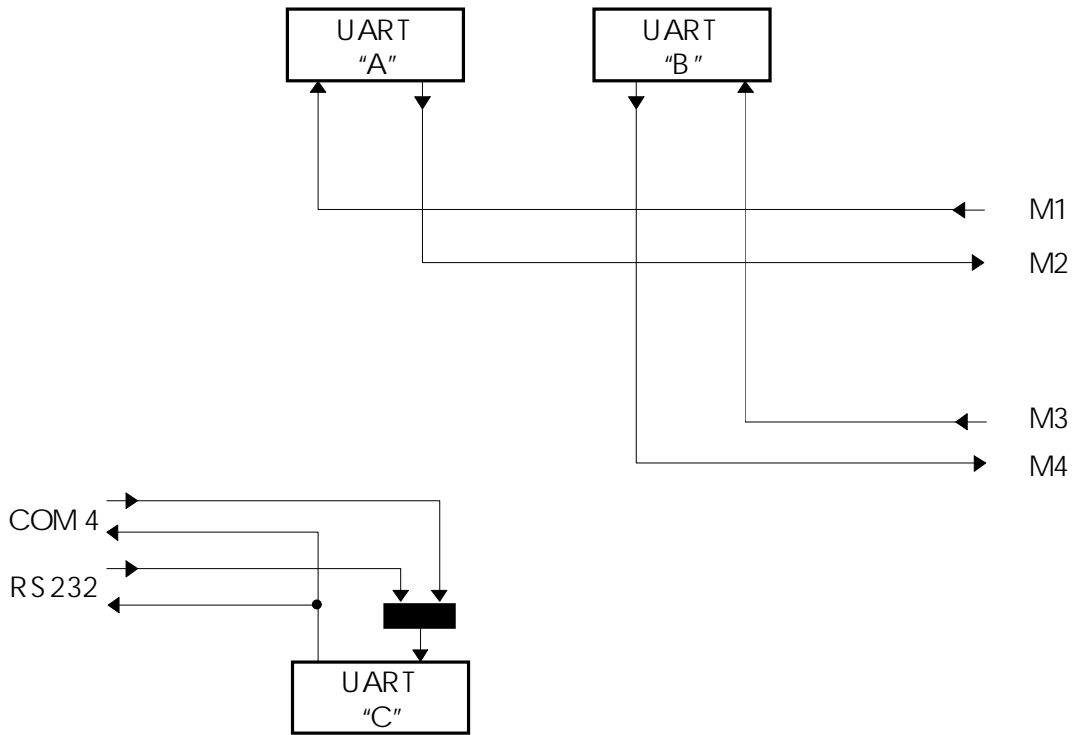

Patchfield No. 4

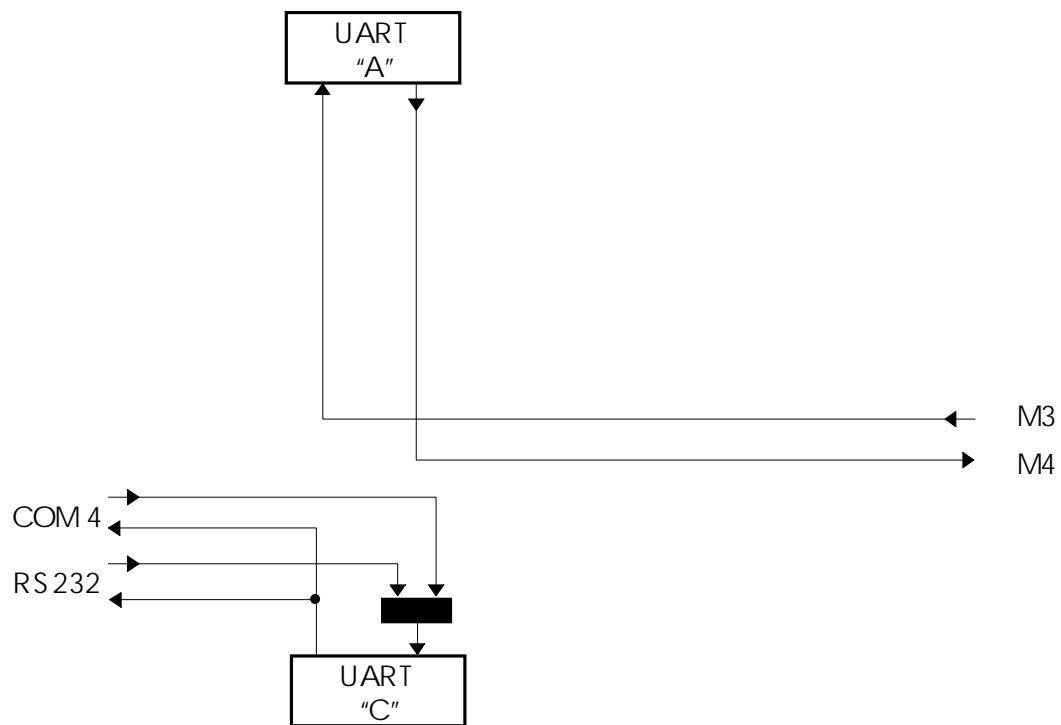

Patchfield No. 5

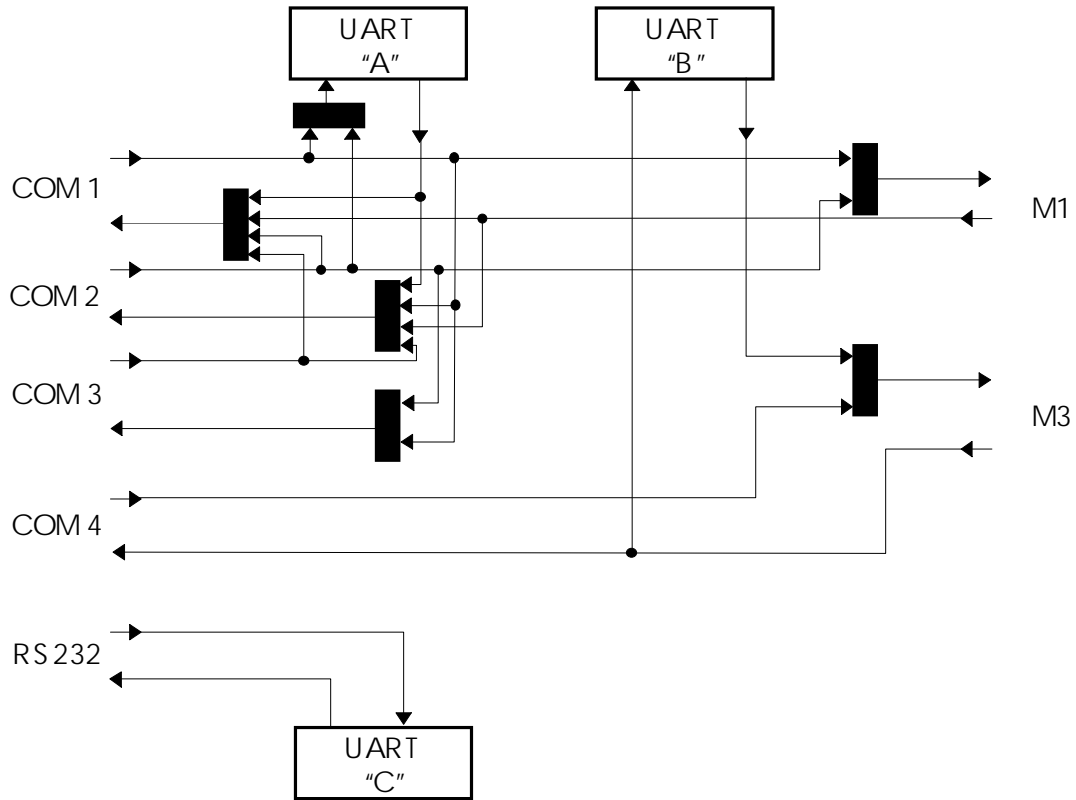

Patchfield No. 6

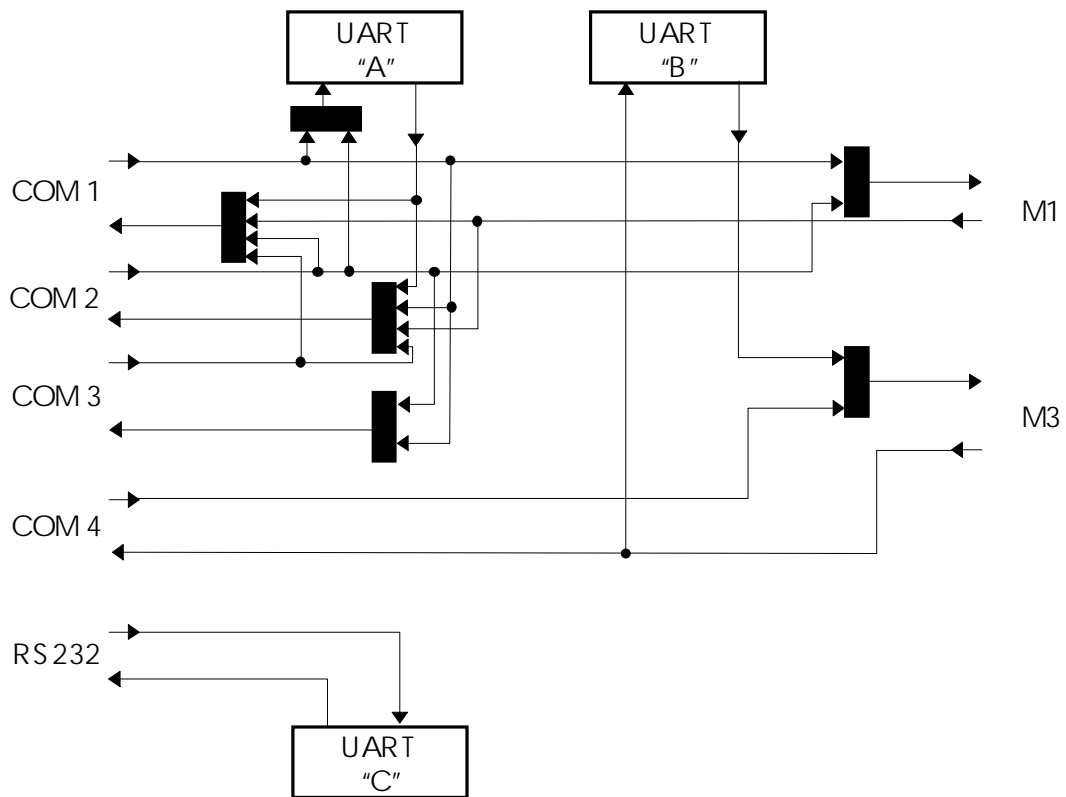

Patchfield No.7

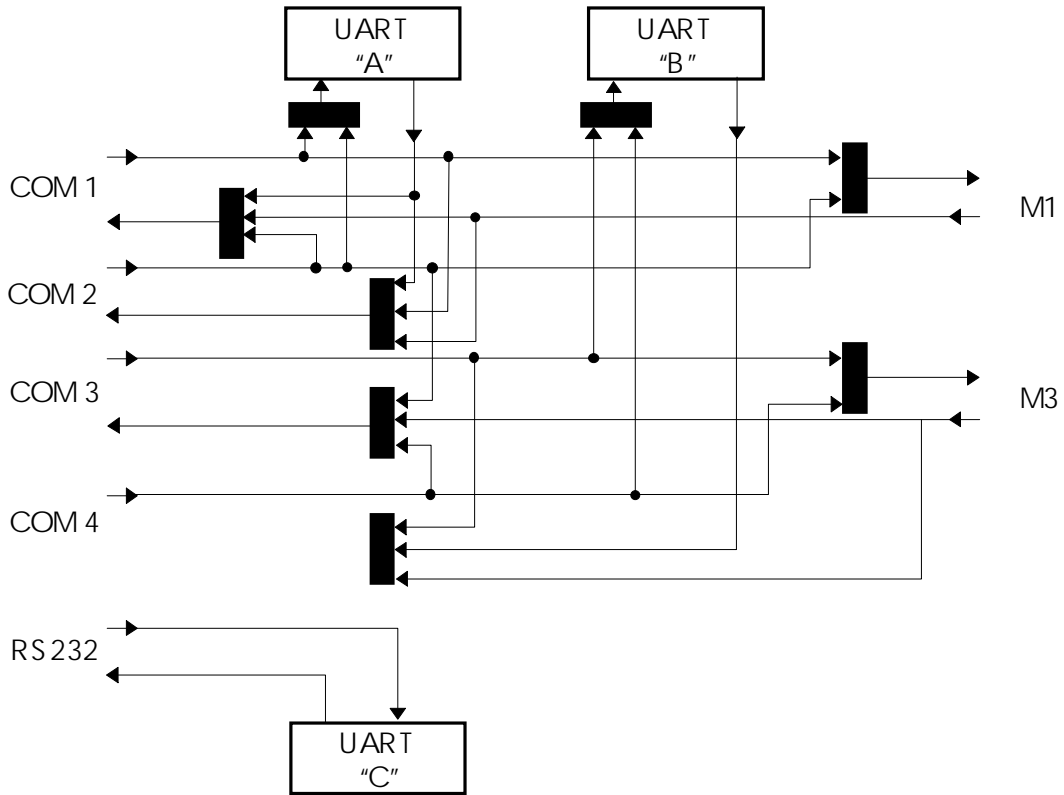

Dual LIU Patchfield DT995D Electrical Diagrams

