

SP XIM, CAM and PIM Installation Guide

© Case Communications Ltd 1994

X890-303551 Issue 2

0-1

Rev.1

Unit 15, Riverside Business Centre, Victoria Street, High Wycombe, Bucks HP11 2LT
Web: www.casecomms.com Email: sales@casecomms.com
Tel (UK): 08700 263 740 Tel (International): +44 (0) 1494 833 740
Fax (UK): 08700 263 741 Fax (International): +44 (0) 1494 833 741

STATUTORY NOTICES

APPROVED for connection to telecommunication systems specified in the instructions for use subject to the conditions set out in them.

NS/1282/1/L/601830 (8425)
NS/1282/1/L/601696 (8525)

WARNING

The 8425 and 8525 have panels in front of the plug-in modules. These panels may only be removed by suitably qualified personnel for installation or maintenance purposes, and must be replaced afterwards. Removal under any other circumstance would invalidate the RFI (Radio Frequency Interference) and Safety type Approvals.

Please refer to Appendix E of this manual for installation of KiloStream ports in the 8425 and 8525.

This equipment generates, uses, and can radiate radio frequency energy and if not installed and used in accordance with the instructions manual, may cause interference to radio communications. It has been tested and found to comply with the limits for a Class A computing device pursuant to Subpart J of Part 15 of FCC Rules, which are designed to provide reasonable protection against such interference when operated in a commercial environment. Operation of this equipment in a residential area is likely to cause interference in which case the user at his own expense will be required to take whatever measures may be required to correct the interference.



Case Communications Ltd declare that this product conforms with the protection requirements of Council Directive 89/336/EEC on the approximation of the laws of the member states relating to electromagnetic protection.

This equipment has been tested using shielded cables supplied by Case Communications Ltd. These cables, or equivalents, must be used to ensure compliance with this declaration.

All PCB assemblies contain Electrostatic Sensitive Devices (ESDs) which may be permanently damaged if incorrectly handled. This equipment must be handled in accordance with BS5783 code of practice for the handling of electrostatic sensitive devices.

Case Communications Limited has made all reasonable efforts to ensure the accuracy of the content of this document but the information contained herein does not constitute a warranty of performance of the equipment and/or software described and no specifications given form part of any contract. This document does not constitute a licence to use or copy any software described herein and any such software must only be used in accordance with the terms of the licence supplied therewith.

Case Communications Limited reserves the right to make alterations to the equipment and software described without notice and assumes no liability for any loss or damage caused as a result of use of this document whether because of out of date or inaccurate information or otherwise.

Product and manufacturers' names referred to in this document are used for identification purposes only and Case Communications Limited acknowledges the intellectual property rights of their respective owners in the same.

This document is the copyright of Case Communications Limited and may not be reproduced, copied or stored in any computerised retrieval system by any means whatsoever without the express written permission of Case Communications Limited.

Published by Case Communications Technical Publications Department

Preface

This guide describes the installation procedures for the Case SP XIM, CAM and PIMs.

These modules will normally be installed by Case engineers. This guide is provided to users for background information, and to assist their Case-trained engineers to install additional modules.

Before reading this guide, you will need to be familiar with 8425 and 8525 terms and operation as provided in the Case Series 8000 Xpress PSE Family Overview, and the Case Series 8000 User Guide.

References

- X890-302551 Case 8425 Installation Guide
- X890-302151 Case 8525 Installation Guide
- X890-302951 Case Series 8000 Xpress V6 PSE Family Overview
- X890-302951 Case Series 8000 V6 User Guide
- X890-301551 Case Series 8000 ACS Installation Guide

Glossary

ACM	Application Connector Module. Generic term for modules fitting in the top slot of Case 8425 or 8525 PSEs.
CAM	Carrier Module. A module which plugs into the rear of Case 8425 or 8525 PSEs carrying 1, 2 or 3 PIMs.
PAM	Physical Access Module. 1) Older, passive type of module used with ACMs other than the SP XIM. 2) Generic term for any module with this outline, including the CAM/PIM combination ('active PAM').
PCB	Printed Circuit Board.
PIM	Port Interface Module. A small two-channel interface card, available in a variety of types, which attaches to a CAM.
PSE	Packet Switch Exchange.
SP XIM	Super XIM/Six Port XIM. An ACM with 6 serial I/O ports and 2 processors.
XIM	X.25 Interface Module. An example of a 'dumb' ACM.

Contents

1	Introduction	1-1
1.1	The Modules	1-1
	1.1.1 The SP XIM	1-2
	1.1.2 The CAM and PIMs	1-2
1.2	Compatibility	1-3
2	Installation Procedure	2-1
2.1	Port Allocation	2-1
2.2	Installing the PIMs on the CAM	2-2
2.3	Connecting the SP XIM Ports	2-4
	2.3.1 General	2-4
	2.3.2 Public Digital Services	2-4
	2.3.3 Use of Screened Cables	2-4
	2.3.4 Pin 1 (Frame Ground) to Signal Ground	2-4
2.4	Other Equipment	2-6
2.5	Running the SP XIM	2-7
	2.5.1 LED Displays	2-7

Appendices

A	Interface Specifications	A-1
B	Cables	B-1
C	Parts List	C-1
D	Firmware Diagnostic Tests	D-1
E	UK PSS and KiloStream	E-1
E.1	General	E-1
E.2	NET1 Considerations	E-3
E.3	NTU Pin Assignments	E-4
E.4	Cable Pinouts	E-6

Figures

1-1	UPM, SP XIM, CAM and PIM Layout	1-1
B-1	V.24 DCE Cables X890-403111 and X890-408611	B-3
B-2	V.24 DTE Cables X890-403011 and X890-408711	B-4
B-3	V.54 DCE Cable X890-406311	B-5
B-4	X.21 Cables X890-401011 and X890-408811	B-6
B-5	V.35 DCE Cables X890-403411 and X890 409411	B-7
B-6	V.35 DTE Cables X890-403311 and X890-409511	B-8
B-7	V.36 DCE Cables X890-406611 and X890-409011	B-9
B-8	V.36 DTE Cables X890-406711 and X890-409111	B-10
E-1	V.24 PSS/KiloStream Cable Part Number X818-401211	E-6
E-2	X.21 PSS/KiloStream Cable Part Number X890-408411	E-7
E-3	V.35 PSS/KiloStream Cable Part Number X818-401311	E-8
E-4	V.36 PSS/KiloStream Cable Part Number X890-406611	E-9

Tables

1-1	PIM Types	1-2
2-1	SP XIM LED Displays	2-4
B-1	V.24 Cables	B-1
B-2	X.21 Cables	B-1
B-3	V.35 Cables	B-2
B-4	V.36 Cables	B-2
B-5	UK PSS/KiloStream NTU Cables	B-2
E-1	Permissible UK PSS/KiloStream Connections	E-1
E-2	V.24 Interface Pin Assignments	E-4
E-3	X.21 Interface Pin Assignments	E-4
E-4	V.35 Interface Pin Assignments	E-5
E-6	V.36 Interface Pin Assignments	E-5

1.1 The Modules

Figure 1-1 illustrates the modules discussed in this installation guide. These are an ACM (specifically the SP XIM), and its active PAM (comprising a CAM and up to three PIMs).

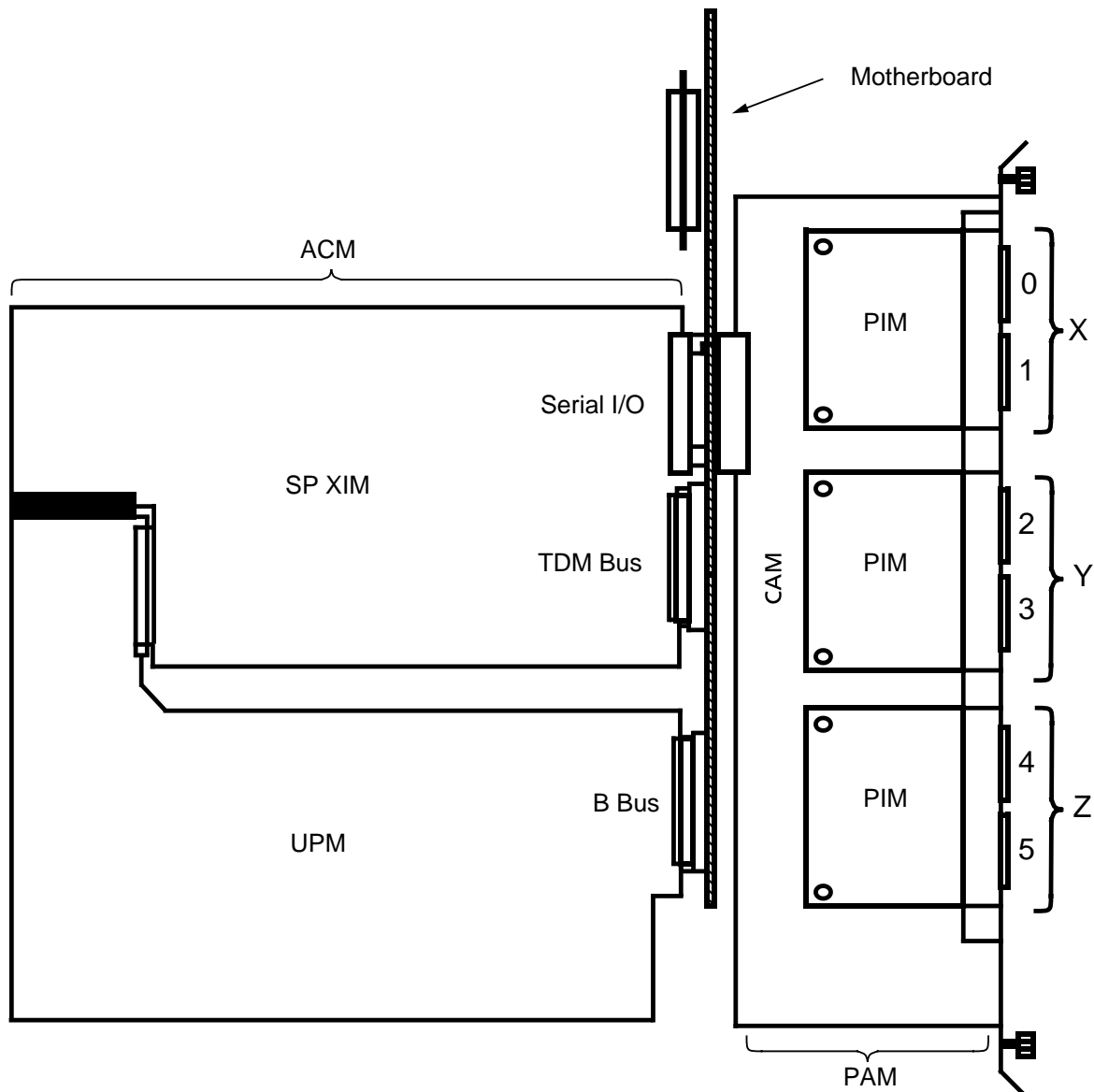

Figure 1-1 UPM, SP XIM, CAM and PIM Layout

1.1.1 The SP XIM

The SP XIM is a Super X.25 Interface Module. It is one of the 8000 Series Application Connector Modules (ACMs) with on-board processing ability, known generically as 'Intelligent ACMs'.

The overall functionality of the SP XIM is defined by the software loaded onto it. Details are given in the user guide for the relevant software product.

The SP XIM has six ports which may run synchronous or asynchronous protocols depending on software.

1.1.2 The CAM and PIMs

Each PIM provides the interface circuitry and physical connectors for two ports.

The PIM positions are referenced X to Z, top to bottom, as viewed from the rear of the card. PIM X supports ports 0 and 1, PIM Y ports 2 and 3, and PIM Z ports 4 and 5. (These port numbers are as defined by the current X.25 operational software.)

An active PAM consists of up to three Port Interface Modules (PIMs) of various types mounted on a Carrier Module (CAM).

PIM TYPE	INTERFACE	CONNECTOR TYPE
PIM 1	V.24 DTE	2 x 25-way D-type male
PIM 2	X.21/V.36 DTE	2 x 15-way D-type male
PIM 3	V.35 DTE	2 x 15-way D-type male
PIM 4	X.21/V.36 DCE	2 x 15-way D-type female
PIM 5	V.24 DCE	2 x 25-way D-type female
PIM 6	X.21 DTE/DCE	1 x 15-way D-type male 1 x 15-way D-type female
PIM 7	X.21 DTE/V.24 DTE	1 x 15-way D-type male 1 x 25-way D-type female

Table 1-1 PIM Types

Note that in each case the designation DTE/DCE refers to the interface presented by each PIM to the attached equipment.

1.2 Compatibility

Module	Cardframes Allowed
SP XIM/CAM	8400, 8425
SP XIM/CAM	8525

The SP XIM cannot be used in an 8500 cardframe owing to mechanical incompatibility with the CAM.

Module	UPMs Allowed
SP XIM	UPM1 X890-601011
SP XIM	UPM2 X890-603311
SP XIM	UPM3 X890-604811
SP XIM	UPM4 X890-607011

Note that the type of UPM required is software-dependent, e.g. the X.25 software requires a UPM3/UPM4.

Module	PAMs Allowed
SP XIM	CAM X890-606011+1, 2 or 3 PIMs (any mix)

Do not connect SP XIM to any type of PAM other than a CAM: permanent damage to the SP XIM may occur.

Do not connect a CAM to any type of ACM other than an SP XIM: permanent damage to the ACM and/or PIMs may occur.

The storage and operational environments of the SP XIM and CAM are as stated in the 8425 and 8525 Installation Guides.

2

Installation Procedure

This equipment must only be installed by fully qualified engineers.

2.1 Port Allocation

PIMs are numbered X to Z starting from the top position on the CAM.

Physical port numbers correspond to PIMs thus:

Port No.		Port No.
0	}	X
1		
2	}	Y
3		
4	}	Z
5		

2.2 Installing the PIMs on the CAM

Each CAM carries up to three PIMs which offer a choice of physical interface in groups of two ports. The following procedures should be followed to initially install or change the required PIMs. They assume that the CAM is viewed with the circuitry uppermost and its rear panel metalwork nearest.

Caution: Ensure that the CAM and PIMs are suitably protected from static discharge during these procedures. An earthing point on the rear of the 8425/8525 chassis may be used to attach suitable wrist straps etc.

To install a PIM:

1. a) Remove the jacking posts from the 25-way D-type connectors, or
b) Remove the four fixing screws from the metalwork around the 15-way D-type connectors.
2. Loosen the fixings of any PIM already fitted to the CAM.
3. Loosen the CAM bracket by slackening the four fixing screws.
4. a) Remove the existing PIM blanking cover, or
b) Gently but firmly lever the existing PIM up so that the plastic pillars disengage from the PIM PCB, allowing the PIM to be removed from the socket strips on the CAM.
5. Carefully locate the PIM, solder-side up, with its interface connectors positioned through the holes in the CAM metalwork.
6. Engage the header strips of the PIMs with the socket strips on the CAM.
7. Check that all pins are correctly located, and gently but firmly press the PIM down so that the plastic pillars locate in the smaller holes of the PIM PCB.
8. Loosely secure the PIM to the CAM rear metalwork using either the jacking posts or fixing screws removed at stage 1.
9. Tighten the fixings of the CAM bracket.
10. Tighten all PIM to CAM bracket fixings. It is important to tighten fully, as the RFI shielding effectiveness depends on ground continuity from PIM to CAM bracket to equipment chassis.

To remove a PIM:

1. a) Remove the jacking posts from the 25-way D-type connectors, or
b) Remove the four fixing screws from the metalwork around the 15-way D-type connectors.
2. Loosen the fixings of any PIM already fitted to the CAM.
3. Loosen the CAM bracket by slackening the four fixing screws.
4. Gently but firmly lever the existing PIM up so that the plastic pillars disengage from the PIM PCB, allowing the PIM to be removed from the socket strips on the CAM.
5. Replace the PIM with a PIM blanking cover (part number X890-904503), secured with four fixing screws.
6. Tighten the fixings of the CAM bracket.
7. Tighten all PIM to CAM bracket fixings. It is important to tighten fully, as the RFI shielding effectiveness depends on ground continuity from PIM to CAM bracket to equipment chassis.

2.3 Connecting the SP XIM Ports

2.3.1 General

The SP XIM ports can be connected using the standard Cray cables listed in Appendices B and C. If non-standard cables are required for a particular installation, refer to Appendix A for details of each interface type.

2.3.2 Public Digital Services

For connection to UK public digital services' network termination units (NTUs), refer to Appendix E, which gives the required statutory and technical information on permissible interfaces, pin-outs and cabling.

For information concerning any statutory requirements for connections to public digital services in countries other than the UK, please contact your distributor or Cray Customer Services.

2.3.3 Use of Screened Cables

The use of the specified screened cables is mandatory if Electro-Magnetic Compatibility (EMC) performance is not to be compromised. Refer to Statutory Notices.

Not all Cray specified cables that connect to conventional D-type connectors on this product are screened. Where screened cables are specified, it is the users responsibility to ensure that any connecting cable is suitably screened to maintain the EMC performance.

2.3.4 Pin 1 (Frame Ground) to Signal Ground

Where D-type connectors are provided on the rear panel(s) for V.24 and X.21 interfaces, Pin 1 (Frame Ground) is connected to Signal ground through the use of a shorting link (0R resistor). However Pin 1 is not normally connected in Cray specified cables. If you are using alternative cables you should seek expert advice, to avoid problems caused by earth-loops created through connections to Pin 1.

Where it is not possible to isolate this connection at any other point in the system, you may remove the relevant resistors. Identify the appropriate port(s) and determine what type of interface card is fitted:

PIM-1, X890-605611, V.24 DTE, 25-way D-types	R1 & R3
PIM-2, X890-605711, X.21 DTE, 15-way D-types	R1 & R3
PIM-3, X890-605811, V.35 DTE, 25-way D-types	No Facility
PIM-4, X890-605911, X.21 DCE, 15-way D-types	R1 & R3
PIM-5, X890-607311, V.24 DTE, 25-way D-types	R1 & R3
PIM-6, X890-607211, X.21 DTE/DCE, 15-way D-types	R4 & R6
PIM-7, X890-607111, V.24 DTE/X.21 DTE, 25/15-way D-types	R2 & R7

2.4 Other Equipment

Check interfaces between the SP XIM and all other equipment which is to be connected (modems, computers, terminals) to ensure compatibility of data and control lines. Any changes necessary must be made in the interconnecting cables.

2.5 Running the SP XIM

The SP XIM must always be attached to a UPM. Normally a UPM3 is needed, to take advantage of the SP XIM performance. Cards may be added and removed while the system is powered up.

To load SP XIM with the desired operating software initially, requires use of the 8425 or 8525 node manager to configure the application for that slot. Thereafter the node manager will automatically load the SP XIM on system power-up, live card insertion or warm restart.

Refer to the 8425 or 8525 Installation Guide for information on system start-up and accessing the node manager.

Protocol-specific configuration details can be found in the relevant user guide for an SP XIM application.

2.5.1 LED Displays

Indications given by the two 7-segment LED displays on the front edge of the SP XIM are dependent on the application software in use: refer to the relevant user guide for details. At power-on or when the SP XIM is reset, all segments light to display 8.

Each SP XIM processor also has one green and one red LED associated with it. The purpose of these is to show processor and inter-processor activity. In normal use they can be expected to flicker at low intensity; a static, brightly-lit condition indicates an error.

GREEN LED	RED LED	MEANING
OFF	OFF	No activity
ON	OFF	Local activity
OFF	ON	(Transient state: not seen)
ON	ON	External DMA activity

Table 2-1 SP XIM LED Displays

Appendix A Interface Specifications

PIM1	Synchronous V.24/RS-232-D DTE
Part Number	X890-605611
Interfaces	2 × 25-way D-type plug (male) DTE
Controls In	CTS, RI, DCD, DSR
Controls Out	DRS, BO, RTS, DTR
Clocks	RxC, TxC, XTxC
Clocking Speeds	Up to 19200 baud

Pin	Signal	Description
1	FG	Frame Ground
2	TxD	Transmit Data
3	RxD	Receive Data
4	RTS	Request To Send
5	CTS	Clear To Send
6	DSR	Data Set Ready
7	GND	Signal Ground
9	DCD	Data Carrier Detect
15	TxC	Transmitter Clock
17	RxC	Receiver Clock
20	DTR	Data Terminal Ready
22	RI	Ring Indicator
23	DRS	Data Rate Select
24	XTxC	Transmitter Clock, DTE source
25	BO	Busy Out

PIM2

Part Number
 Interfaces
 Controls In
 Controls Out
 Clock
 Clock Source
 Clocking Speeds

Synchronous X.21 DTE

X890-605711
 2 × 15-way D-type plug (male) DTE
 Indication
 Control
 Signal Element Timing 'S'
 External
 Up to 256000 baud

PIM2

Part Number
 Interfaces
 Controls In
 Controls Out
 Clocks
 Clocking Speeds

Synchronous V.36 DTE

X890-605711
 2 × 15-way D-type plug (male) DTE
 DCD
 RTS, DTR*
 RxC, TxC
 Up to 256000 baud

Pin	X.21 Signal	Description	V.36 Equivalent Signals*
1	FG	Frame Ground	–
2	T(A)	Transmit Data+	TxD(A)
3	C(A)	Control+	RTS(A), DTR(A)
4	R(A)	Receive Data+	RxD(A)
5	I(A)	Indication+	DCD(A)
6	S(A)	Clock+	RxC(A), TxC(A)
8	G	Signal Ground	SGND
9	T(B)	Transmit Data –	TxD(B)
10	C(B)	Control –	RTS(B), DTR(B)
11	R(B)	Receive Data –	RxD(B)
12	I(B)	Indication –	DCD(B)
13	S(B)	Clock –	RxC(B), TxC(B)

* using V.36 DCE cable of Figure C-7.

PIM3**Synchronous V.35 DTE**

Part Number	X890-605811
Interfaces	2 × 15-way D-type plug (male) DTE
Controls In	CTS, DCD
Controls Out	RTS
Clocks	RxC, TxC, XTxC
Clocking Speeds	Up to 256000 baud

Pin	Signal	Description
1	DCD	Data Carrier Detect
2	TxD(A)	Transmit Data+
3	RTS	Request To Send
4	RxD(A)	Receive Data+
5	RxC(A)	Receive Clock+
6	TxC(A)	Transmit Clock+
7	XTxC(A)	Transmit Clock+ (DTE source)
8	GND	Signal Ground
9	TxD(B)	Transmit Data –
11	RxD(B)	Receive Data –
12	RxC(B)	Receive Clock –
13	TxC(B)	Transmit Clock –
14	XTxC(B)	Transmit Clock – (DTE source)
15	CTS	Clear To Send

PIM4

Part Number
 Interfaces
 Controls In
 Controls Out
 Clock
 Clock Source
 Clocking Speeds

Synchronous X.21 DCE

X890-605911
 2 × 15-way D-type plug (female) DCE
 Control
 Indication
 Signal Element Timing 'S'
 Internal
 2400, 4800, 7200, 9600, 19200, 48000,
 64000, 128000 and 256000 baud

PIM4

Part Number
 Interfaces
 Controls In
 Controls Out
 Clocks
 Clocking Speeds

Synchronous V.36 DCE

X890-605911
 2 × 15-way D-type plug (female) DCE
 RTS
 DCD
 RxC, TxC
 2400, 4800, 7200, 9600, 19200, 48000,
 64000, 128000 and 256000 baud

Pin	Signal	Description	V.36 Equivalent Signals*
1	FG	Frame Ground	–
2	T(A)	Transmit Data+	TxD(A)
3	C(A)	Control+	RTS(A)
4	R(A)	Receive Data+	RxD(A)
5	I(A)	Indication+	DCD(A)
6	S(A)	Clock+	RxC(A), TxC(A)
8	G	Signal Ground	SGND
9	T(B)	Transmit Data –	TxD(B)
10	C(B)	Control –	RTS(B)
11	R(B)	Receive Data –	RxD(B)
12	I(B)	Indication –	DCD(B)
13	S(B)	Clock –	RxC(B), TxC(B)

* using V.36 DTE cable of Figure C-8.

PIM5 Synchronous V.24/RS-232-D DCE

Part Number	X890-607311
Interfaces	2 × 25-way D-type plug (female) DCE
Controls Out	CTS, RI, DCD, DSR
Controls In	DRS, BO, RTS, DTR
Clocks	RxC, TxC, XTxC
Clocking Speeds	Up to 19200 baud

Pin	Signal	Description
1	FG	Frame Ground
2	TxD	Transmit Data
3	RxD	Receive Data
4	RTS	Request To Send
5	CTS	Clear To Send
6	DSR	Data Set Ready
7	GND	Signal Ground
9	DCD	Data Carrier Detect
15	TxC	Transmitter Clock
17	RxC	Receiver Clock
20	DTR	Data Terminal Ready
22	RI	Ring Indicator
23	DRS	Data Rate Select
24	XTxC	Transmitter Clock, DTE source
25	BO	Busy Out

PIM6 port a**Synchronous X.21 DTE**

Part Number	X890-607211
Interface	15-way D-type plug (male) DTE
Controls In	Indication
Controls Out	Control
Clock	Signal Element Timing 'S'
Clock Source	External
Clocking Speeds	Up to 256000 baud

Pin	X.21 Signal	Description
1	FG	Frame Ground
2	T(A)	Transmit Data+
3	C(A)	Control+
4	R(A)	Receive Data+
5	I(A)	Indication+
6	S(A)	Clock+
8	G	Signal Ground
9	T(B)	Transmit Data -
10	C(B)	Control -
11	R(B)	Receive Data -
12	I(B)	Indication -
13	S(B)	Clock -

PIM6 port b

Part Number
Interface
Controls In
Controls Out
Clock
Clock Source
Clocking Speeds

Synchronous X.21 DCE

X890-607211
15-way D-type plug (female) DCE
Control
Indication
Signal Element Timing 'S'
Internal
2400, 4800, 7200, 9600, 19200, 48000,
64000, 128000 and 256000 baud

Pin	Signal	Description
1	FG	Frame Ground
2	T(A)	Transmit Data+
3	C(A)	Control+
4	R(A)	Receive Data+
5	I(A)	Indication+
6	S(A)	Clock+
8	G	Signal Ground
9	T(B)	Transmit Data -
10	C(B)	Control -
11	R(B)	Receive Data -
12	I(B)	Indication -
13	S(B)	Clock -

PIM7 port a**Synchronous X.21 DTE**

Part Number	X890-607111
Interface	15-way D-type plug (male) DTE
Controls In	Indication
Controls Out	Control
Clock	Signal Element Timing 'S'
Clock Source	External, Internal
Clocking Speeds	Internal: 2400, 4800, 7200, 9600, 19200, 48000, 64000, 128000 and 256000 External: up to 256000

Pin	X.21 Signal	Description
1	FG	Frame Ground
2	T(A)	Transmit Data+
3	C(A)	Control+
4	R(A)	Receive Data+
5	I(A)	Indication+
7	CLK(A)	Clock Out+
6	S(A)	Clock+
8	G	Signal Ground
9	T(B)	Transmit Data -
10	C(B)	Control -
11	R(B)	Receive Data -
12	I(B)	Indication -
13	S(B)	Clock -
14	CLK(B)	ClockOut -

PIM7 port b**Synchronous V.24/RS-232-D DTE**

Part Number	X890-607111
Interface	25-way D-type plug (male) DTE
Controls In	CTS, RI, DCD, DSR
Controls Out	DRS, BO, RTS, DTR
Clocks	RxC, TxC, XTxC
Clocking Speeds	Up to 19200 baud

Pin	Signal	Description
1	FG	Frame Ground
2	TxD	Transmit Data
3	RxD	Receive Data
4	RTS	Request To Send
5	CTS	Clear To Send
6	DSR	Data Set Ready
7	GND	Signal Ground
9	DCD	Data Carrier Detect
15	TxC	Transmitter Clock
17	RxC	Receiver Clock
20	DTR	Data Terminal Ready
22	RI	Ring Indicator
23	DRS	Data Rate Select
24	XTxC	Transmitter Clock, DTE source
25	BO	Busy Out

This appendix gives the part number and pinout for all available standard cables.

PIM TYPE	PIM INTERFACE TYPE	REMOTE INTERFACE TYPE	LENGTH	PART NUMBER	PINOUT DIAGRAM
PIM1/7	DTE	DCE	3M	X890-403111	B-1
PIM1/7	DTE	DCE	5M	X890-408611	B-1
PIM1/7	DTE	DTE	3M	X890-403011	B-2
PIM1/7	DTE	DTE	5M	X890-408711	B-2

Refer to the Series 8000 Xpress PSE User Guide for V.54 cable applications.

Table B-1 V.24 Cables

PIM TYPE	PIM INTERFACE TYPE	REMOTE INTERFACE TYPE	LENGTH	PART NUMBER	PINOUT DIAGRAM
PIM2/6/7	DTE	DCE	3M	X890-401011	B-4
PIM2/6/7	DTE	DCE	5M	X890-408811	B-4
PIM2/6/7	DCE	DTE	3M	X890-401011	B-4
PIM2/6/7	DCE	DTE	5M	X890-408811	B-4

Note that X.21 DTE and DCE cables are identical. To change a port from a DCE connection to a DTE connection, replace the PIM2 with a PIM4, or use an alternative port on PIM6.

Table B-2 X.21 Cables

PIM TYPE	PIM INTERFACE TYPE	REMOTE INTERFACE TYPE	LENGTH	PART NUMBER	PINOUT DIAGRAM
PIM3	DTE	DCE	3M	X890-403411	B-5
PIM3	DTE	DCE	5M	X890-409411	B-5
PIM3	DTE	DTE	3M	X890-403311	B-6
PIM3	DTE	DTE	5M	X890-409511	B-6

Table B-3 V.35 Cables

PIM TYPE	PIM INTERFACE TYPE	REMOTE INTERFACE TYPE	LENGTH	PART NUMBER	PINOUT DIAGRAM
PIM2/6/7	DTE	DCE	3M	X890-406611	B-7
PIM2/6/7	DTE	DCE	5M	X890-409011	B-7
PIM2/6/7	DCE	DTE	3M	X890-406711	B-8
PIM2/6/7	DCE	DTE	5M	X890-409111	B-8

Table B-4 V.36 Cables

PIM TYPE	PIM INTERFACE TYPE	REMOTE INTERFACE TYPE	LENGTH	PART NUMBER	PINOUT DIAGRAM
PIM1/7	V.24 DTE	V.24 NTU	5M	X818-401211	D-1
PIM2/6/7	X.21 DTE	X.21 NTU	5M	X890-408411	D-2
PIM3	V.35 DTE	V.35 NTU	5M	X818-401311	D-3

Refer to Appendix D for cable pinout diagrams.

Table B-5 UK PSS/KiloStream NTU Cables

INTERFACE TYPE	REMOTE INTERFACE TYPE	LENGTH	PART NUMBER	PINOUT DIAGRAM
8-way DIN	DTE	0.7M	X870-401511	C-9

Table B-6 Diagnostic/Manager Port

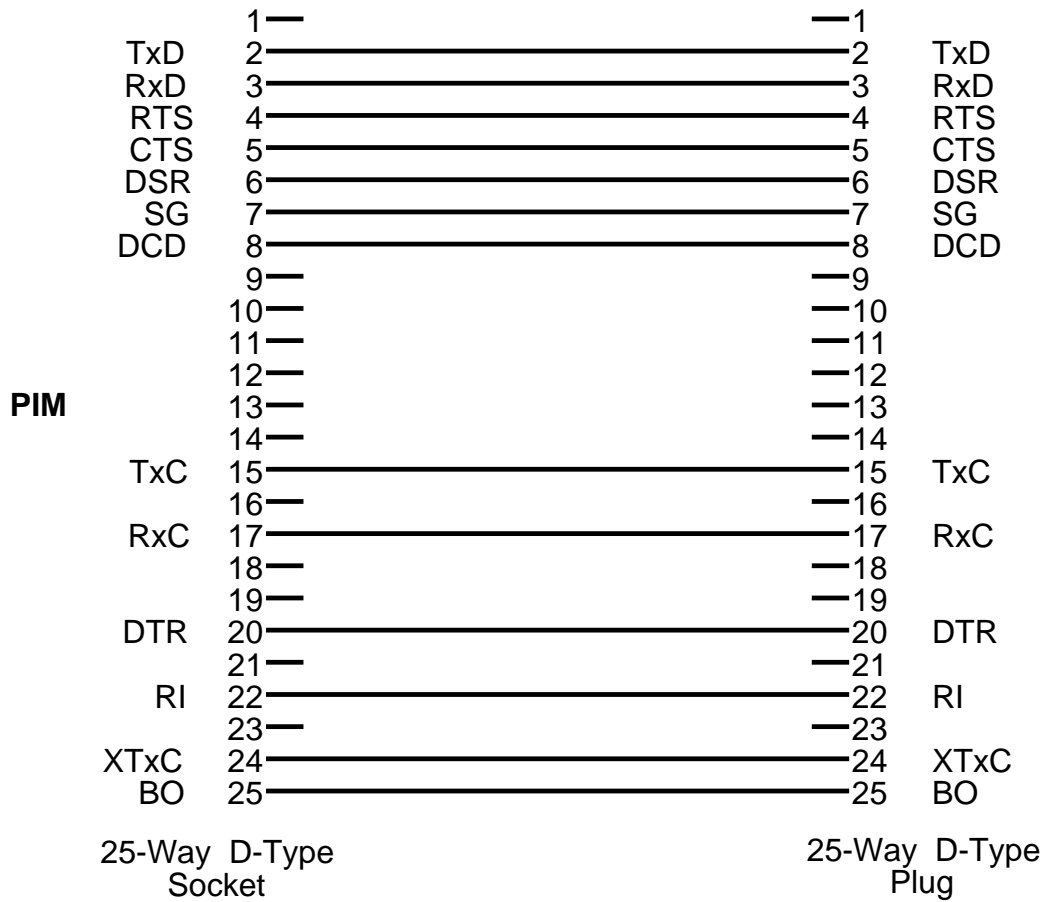

Figure B-1 V.24 DCE Cables X890-403111 and X890-408611

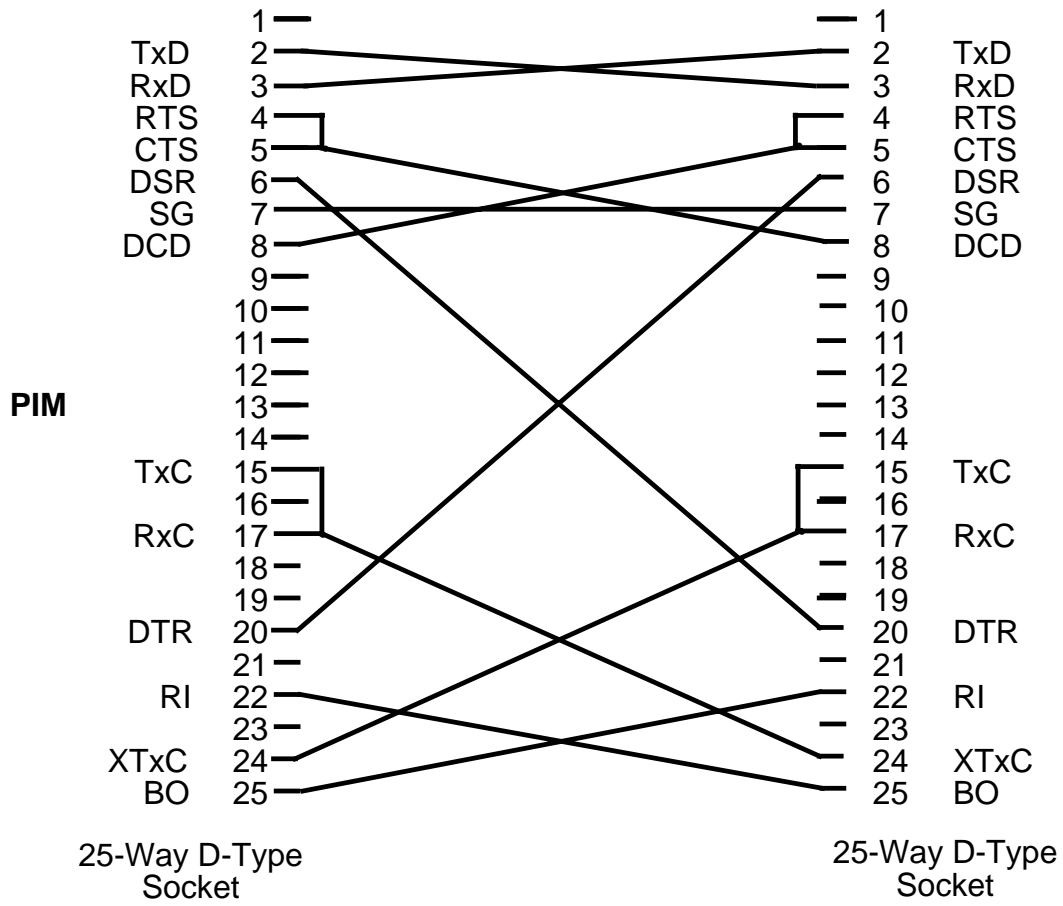

Figure B-2 V.24 DTE Cables X890-403011 and X890-408711

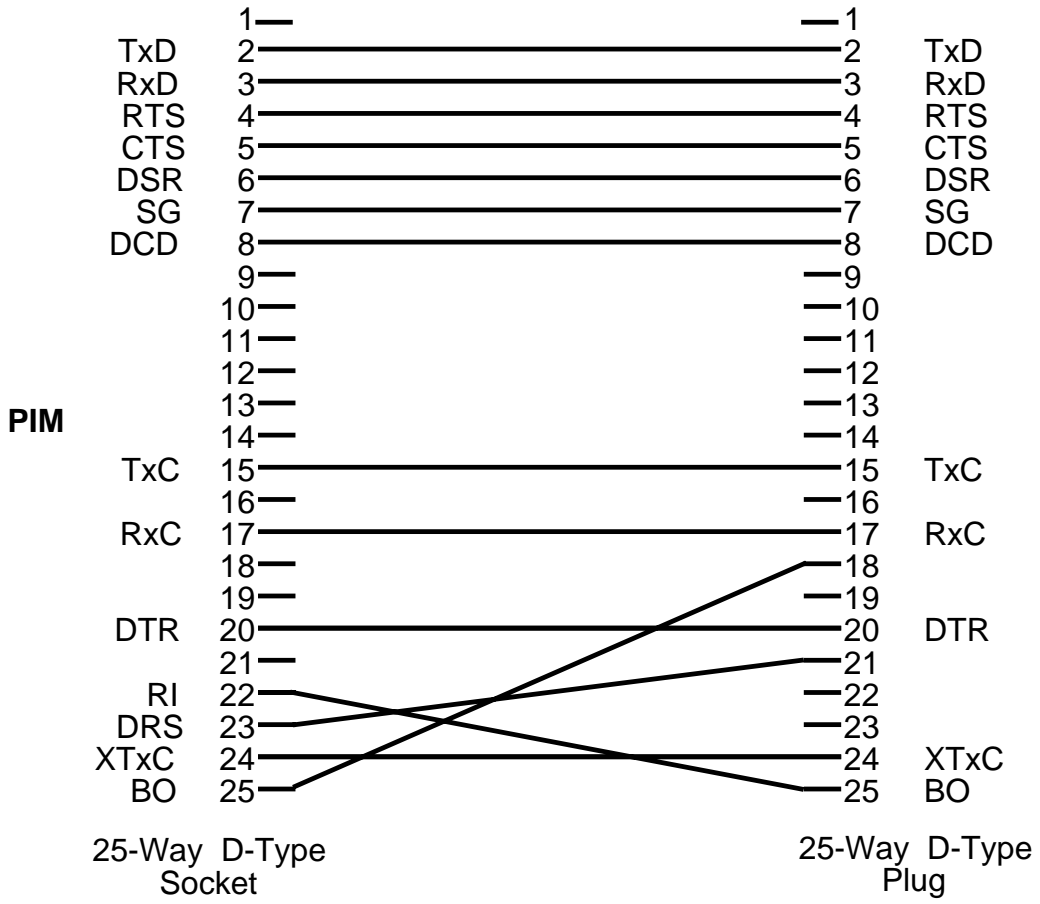

Figure B-3 V.54 DCE Cable X890-406311

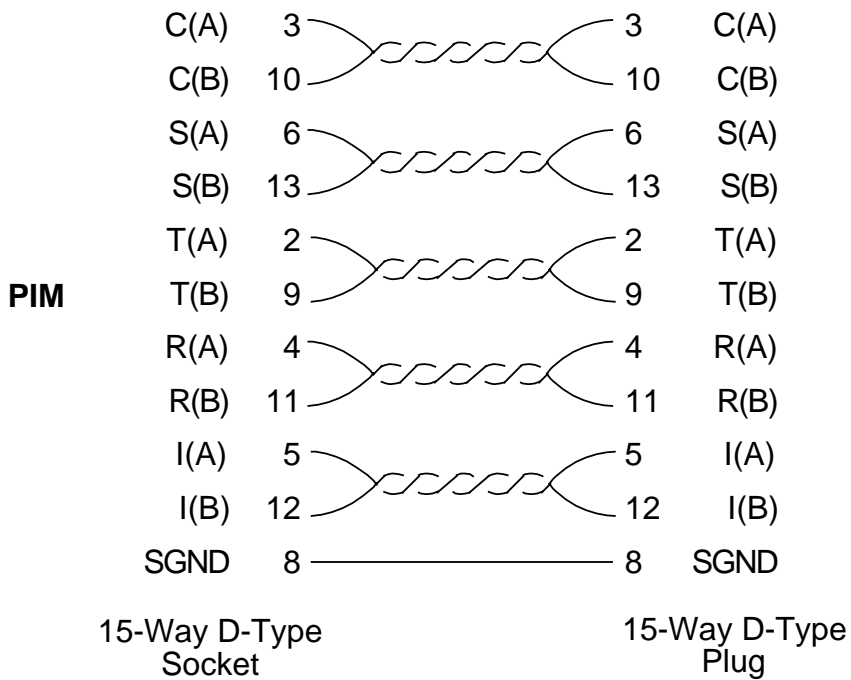

Figure B-4 X.21 Cables X890-401011 and X890-408811

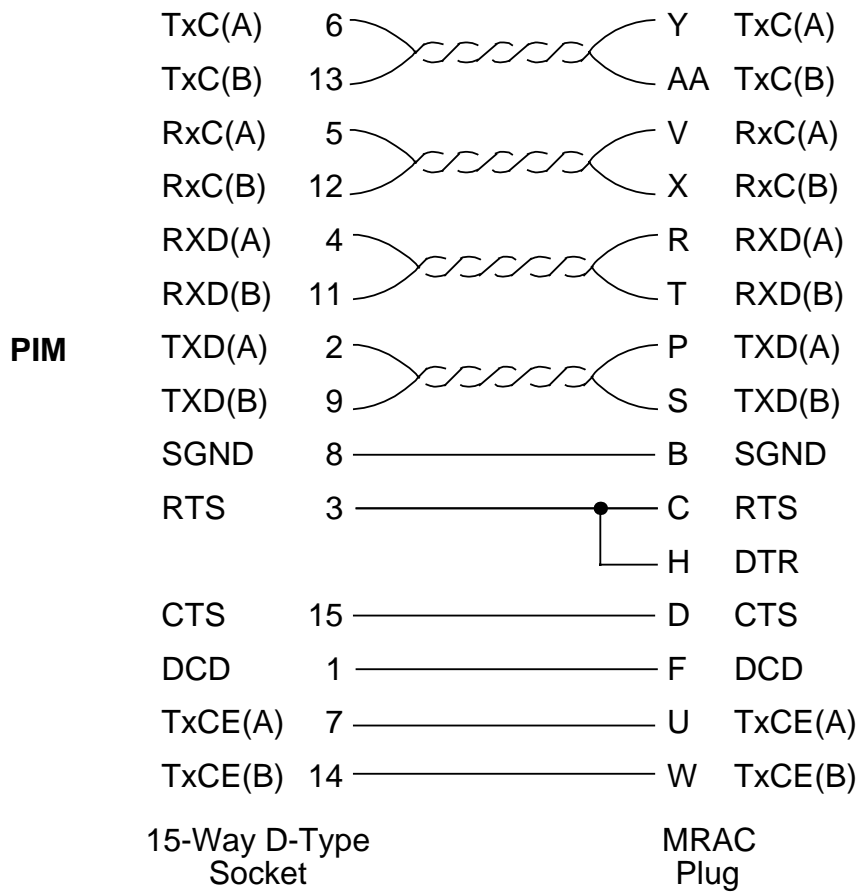

Figure B-5 V.35 DCE Cables X890-403411 and X890-409411

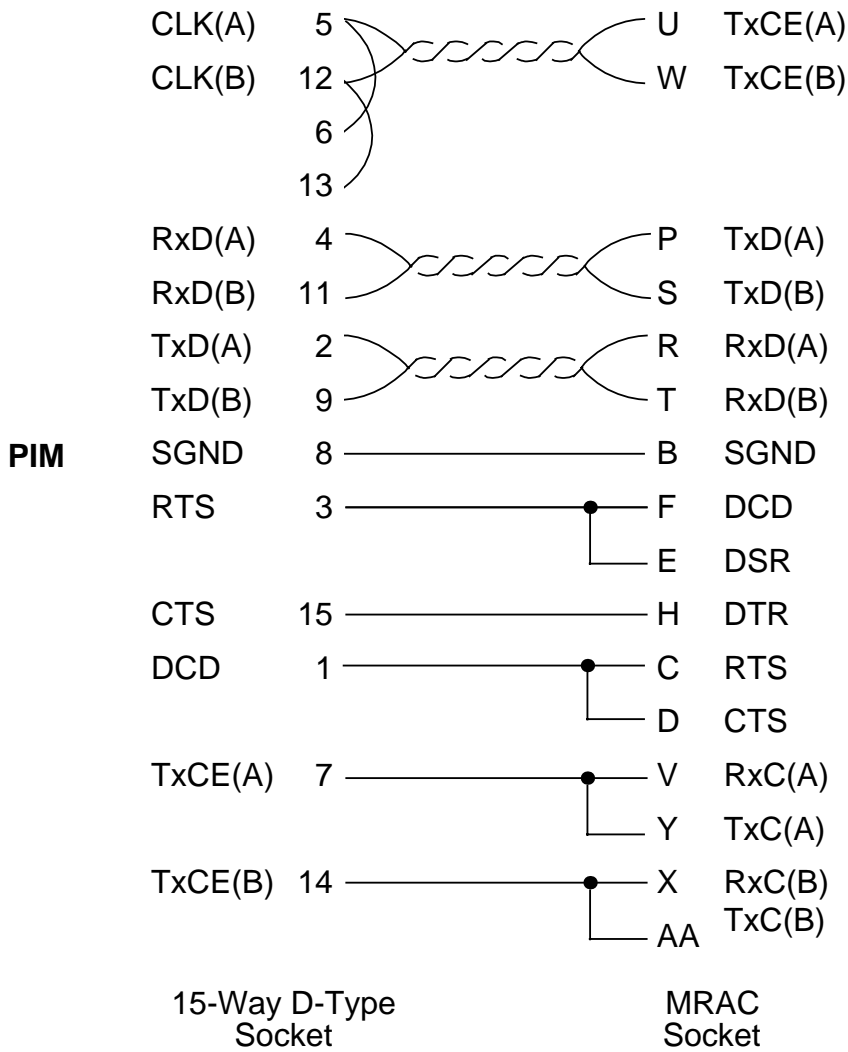

Figure B-6 V.35 DTE Cables X890-403311 and X890-409511

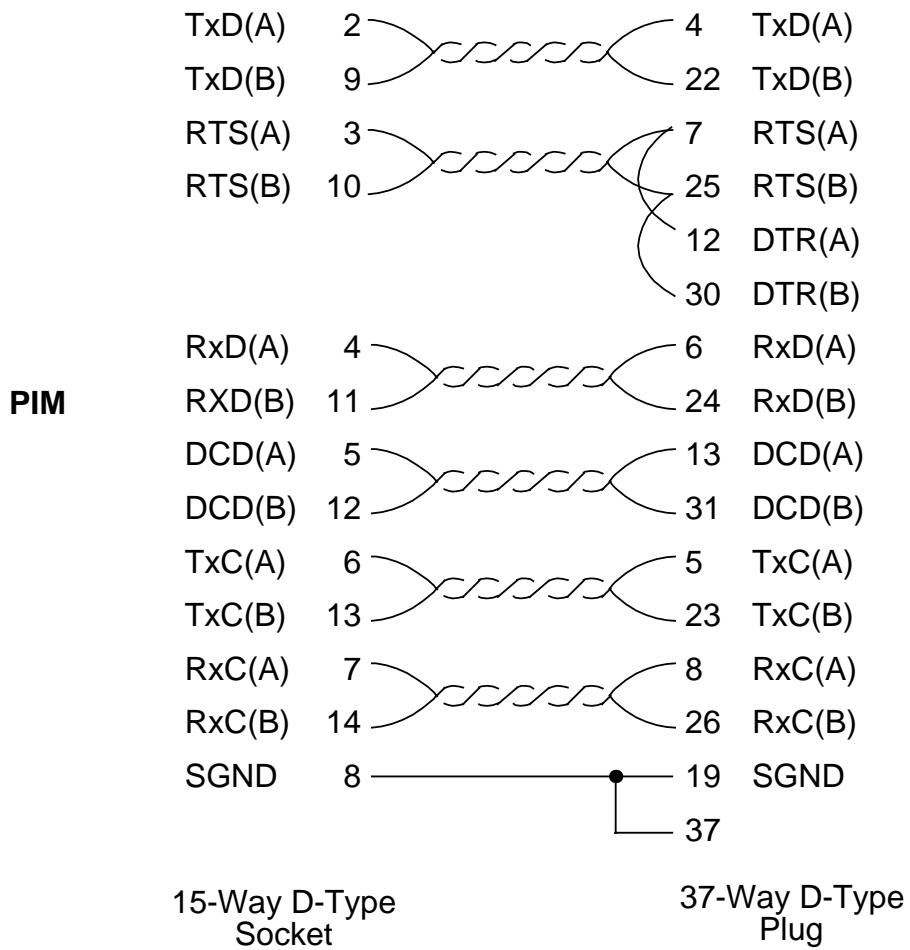

Figure B-7 V.36 DCE Cables X890-406611 and X890-409011

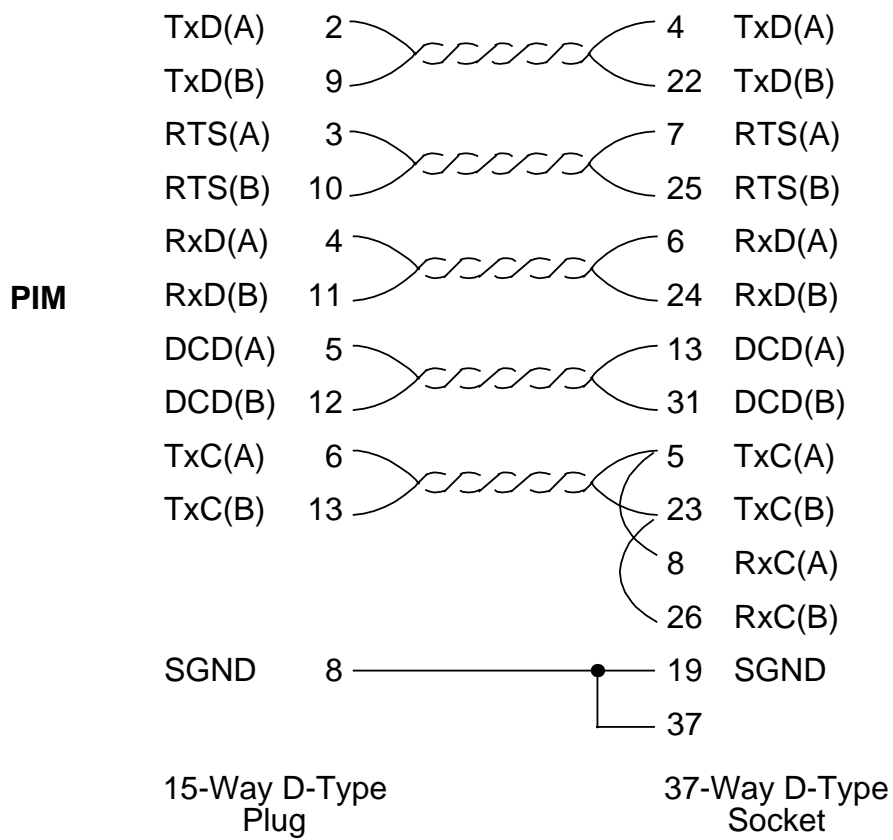

Figure B-8 V.36 DTE Cables X890-406711 and X890-409111

SP XIM	X890-606111
CAM	X890-606011
PIM1	X890-605611
PIM2	X890-605711
PIM3	X890-605811
PIM4	X890-605911
PIM5	X890-607311
PIM6	X890-607211
PIM7	X890-607111
PIM Blanking Plate	X890-904503
Diagnostic Cable	X100-403811

For other cable part numbers refer to Appendix B.

UPM Tests (Numbers 1-127 allocated)

Test	Description
1	EPROM Checksum
2	DRAM Data/Addressing
3	DRAM Refresh
4	Random Data Pattern
5	DRAM Execution
6	Bus Cycle and Software Watchdog
7	VIA Device
8	No test
9	Vector Table Read/Write
10	No test
11	Novram Checksum, RAM Read/Write
12	DMAC reg. R/W, INT, memory transfer
13	No test
14	No test
15	ULA non-DMA R/W Transfers
16	ULA Fly-by DMA R/W Transfers
17	No test
18	ULA Packet TX and RX
19	ULA TX Error Interrupt
20	ULA TX Nogo Interrupt and Counter
21	ULA Clock Fail Interrupt
22	ULA Supervisor/Data Flag Check
23	ULA RX/TX Length Counters
24-29	No test
30	ULA System Test Reflector
31-47	ULA Packet TX/RX for Test 30

SP XIM Tests (Numbers 128-255 allocated)

Test	Description
128	Upper EPROM Checksum
129	Lower EPROM Checksum
130	NOVRAM Checksum and Read/Write
131	NOVRAM Recall
132	Control Bits
133	SIC Configuration
134	PPI0
135	PPI1
136	PPI2
137	IMP1 – Internal RAM
138	IMP2 – Internal RAM
139	IMP1 – DRAM Lower Bank data
140	IMP1 – DRAM Lower Bank address
141	IMP1 – DRAM Upper Bank data
142	IMP1 – DRAM Upper Bank address
143	IMP2 – DRAM Lower Bank data
144	IMP2 – DRAM Lower Bank address
145	IMP2 – DRAM Upper Bank data
146	IMP2 – DRAM Upper Bank address
147-149	No test
150	IMP1 to UPM Interrupt
151	IMP2 to UPM Interrupt
152	IMP1 - DMA to/from UPM
153	IMP2 - DMA to/from UPM
154-159	No test
160	IMP1 – Execution
161	IMP2 – Execution
162	IMP1 – DRAM
163	IMP2 – DRAM
164	UPM to IMP1 DRAM
165	UPM to IMP2 DRAM
166	IMP1 to IMP2 DRAM
167	IMP1 to UPM DRAM
168	IMP1 to PPI0
169	IMP2 to IMP1 DRAM
170	IMP2 to UPM DRAM
171	IMP2 to PPI1
172	UPM to IMP1 Interrupt

173	UPM to IMP2 Interrupt
174	IMP1 to IMP2 Interrupt
175	IMP1 to UPM Interrupt
176	IMP2 to IMP1 Interrupt
177	IMP2 to UPM Interrupt
178	IMP2 to IMP1 Interrupt (mode 1)
179	IMP2 DMA to/from IMP1 (mode 1)
180	Channel 1 TxD - RxD Loop
181	Channel 1 RTS - CTS Loop
182	Channel 1 DTR - DSR Loop
183	Channel 1 DTR - DCD Loop
184	Channel 1 BO - RI Loop
185	Channel 1 DRS - TXC Loop
186	Channel 1 TxCE - RxC Loop
187	Channel 2 TxD - RxD Loop
188	Channel 2 RTS - CTS Loop
189	Channel 2 DTR - DSR Loop
190	Channel 2 DTR - DCD Loop
191	Channel 2 BO - RI Loop
192	Channel 2 DRS - TxC Loop
193	Channel 2 TxCE - RxC Loop
194	Channel 3 TxD - RxD Loop
195	Channel 3 RTS - CTS Loop
196	Channel 3 DTR - DSR Loop
197	Channel 3 DTR - DCD Loop
198	Channel 3 BO - RI Loop
199	Channel 3 DRS - TxC Loop
200	Channel 3 TxCE - RxC Loop
201	Channel 4 TxD - RxD Loop
202	Channel 4 RTS - CTS Loop
203	Channel 4 DTR - DSR Loop
204	Channel 4 DTR - DCD Loop
205	Channel 4 BO - RI Loop
206	Channel 4 DRS - TxC Loop
207	Channel 4 TxCE - RxC Loop
208	Channel 5 TxD to RxD loop
209	Channel 5 RTS to CTS loop
210	Channel 5 DTR to DSR loop
211	Channel 5 DTR to DCD loop
212	Channel 5 DSR to TxC loop
213	Channel 5 BO to RI loop

214	Channel 5 TxCE to RxC loop
215	Channel 6 RTS to CTS loop
216	Channel 6 RTS to CTS loop
217	Channel 6 DTR to DSR loop
218	Channel 6 DTR to DCD loop
219	Channel 6 DSR to TxC loop
220	Channel 6 BO to RI loop
221	Channel 6 TxCE to RxC loop
222-255	No test

Appendix E UK PSS and KiloStream

E.1 General

Ports labelled "SAFETY WARNING See Instructions For Use" do not provide isolation sufficient to satisfy the requirements of the relevant parts of BS 6301. Apparatus connected to these ports must itself either be approved to the relevant parts of BS 6301 or have previously been evaluated against British Telecom (Post Office) Technical Guide 2 or 26 and been granted permission for attachment. **Other usage will invalidate any approval given to this apparatus.**

In order to meet the safety requirements of our PSS/KiloStream approval it is important to make sure that the equipment is correctly installed and maintained.

When delivered from the factory for use in the UK the physical interfaces of ports which can be connected to PSS and KiloStream are given in Table E-1. **Note that PIM4 and PIM5 ports are prohibited from connection:**

INTERFACE TYPE	PIM TYPE	LINE SPEED	CONNECTOR TYPE	CABLE PART NUMBER
V.24	1, 7	≤ 19200 bps	2 x 25-way D-type male (DTE)	X818-401211
X.21	2, 6, 7	≤ 64 kbps	2 x 15-way D-type male (DTE)	X890-408411
V.35	3	≤ 64 kbps	2 x 15-way D-type male (DTE)	X818-401311
V.36	2, 6, 7	≤ 64 kbps	15-way to 37-way D-type male (DTE)	X890-406611

Table E-1 Permissible UK PSS/KiloStream Connections

Connection to PSS and KiloStream NTUs must be made with the cables specified in Table G-1, and they must be installed by a competent engineer.

If **any** connections on a PAM are connected to PSS or KiloStream then **all other** connections on that PAM must be to apparatus that has either been approved to the relevant parts of BS 6301 or has previously been evaluated against British Telecom (Post Office) Technical Guide 2 or 26 and been granted permission for attachment. **Other usage will invalidate any approval given to this apparatus.** If there is any doubt as to the suitability of the equipment, then the advice of a competent engineer should be sought.

E.2 NET1 Considerations

The X.21 interfaces on SP XIM **do not** provide 'DTE Uncontrolled NOT READY'.

V.24, X.21 and V.35 interfaces are approved for direct connection to digital networks using the cables specified in Table E-1.

The V.24 interfaces are for connection to PTO Service Category 1.

The V.35 interfaces are for connection to PTO Service Category 2.

The V.24 interface can only operate up to 9K6 bps for PSS connection, but up to 19K2 bps for KiloStream connection.

E.3 NTU Pin Assignments

Tables E-2 to E-4 show the V.24, X.21 and V.35 interface pin assignments presented to a PSS/KiloStream NTU at the NTU end of the cables specified in Table E-1. For the pinouts at the PIM end of the cables refer to Appendix A.

PIN NO.	DIRECTION	ASSIGNMENT
2	Output	Transmit Data (TxD)
3	Input	Receive Data (RxD)
4	Output	Request To Send (RTS)
5	Input	Clear To Send (CTS)
6	Input	Data Set Ready (DSR)
7	–	Signal Ground (SGND)
8	Input	Data Carrier Detect (DCD)
15	Input	Transmit Clock (TxC)
17	Input	Receive Clock (RxC)
20	Output	Data Terminal Ready (DTR)

**Table E-2 V.24 Interface Pin Assignments
(At NTU End of Cable X818-401211)**

PIN NO.	DIRECTION	ASSIGNMENT
3	Output	Control (CA)
10	Output	Control (CB)
6	Input	Signal Element Timing (SA)
13	Input	Signal Element Timing (SB)
2	Output	Transmit Data (TA)
9	Output	Transmit Data (TB)
4	Input	Receive Data (RA)
11	Input	Receive Data (RB)
5	Input	Indication (IA)
12	Input	Indication (IB)
8	–	Signal Ground (G)

**Table E-3 X.21 Interface Pin Assignments
(At NTU End of Cable X890-408411)**

PIN NO.	DIRECTION	ASSIGNMENT
Y	Input	Transmit Clock (TxCA)
AA	Input	Transmit Clock (TxCB)
V	Input	Receive Clock (RxCA)
X	Input	Receive Clock (RxCB)
R	Input	Receive Data (RxDA)
T	Input	Receive Data (RxDB)
P	Output	Transmit Data (TxDA)
S	Output	Transmit Data (TxDB)
B	–	Signal Ground
C/H	Output	Request To Send (RTS)
D	Input	Ready for Sending (RFS)
F	Input	Data Carrier Detect (DCD)

**Table E-4 V.35 Interface Pin Assignments
(At NTU End of Cable X818-401311)**

PIN NO.	DIRECTION	ASSIGNMENT
4	Output	TxD (A)
22	Output	TxD (B)
7	Output	RTS (A)
25	Output	RTS (B)
12	Output	DTR (A)
30	Output	DTR (B)
6	Input	RxD (A)
24	Input	RxD (B)
13	Input	DCD (A)
31	Input	DCD (B)
5	Input	TxC (A)
23	Input	TxC (B)
8	Input	RxC (A)
26	Input	RxC (B)
19	–	SGND
37	–	SGND

**Table E-5 V.36 Interface Pin Assignments
(At NTU End of Cable X890-406611)**

E.4 Cable Pinouts

Figures E-1 to E-3 give the pinouts of the three PSS/KiloStream cables listed in Table E-1.

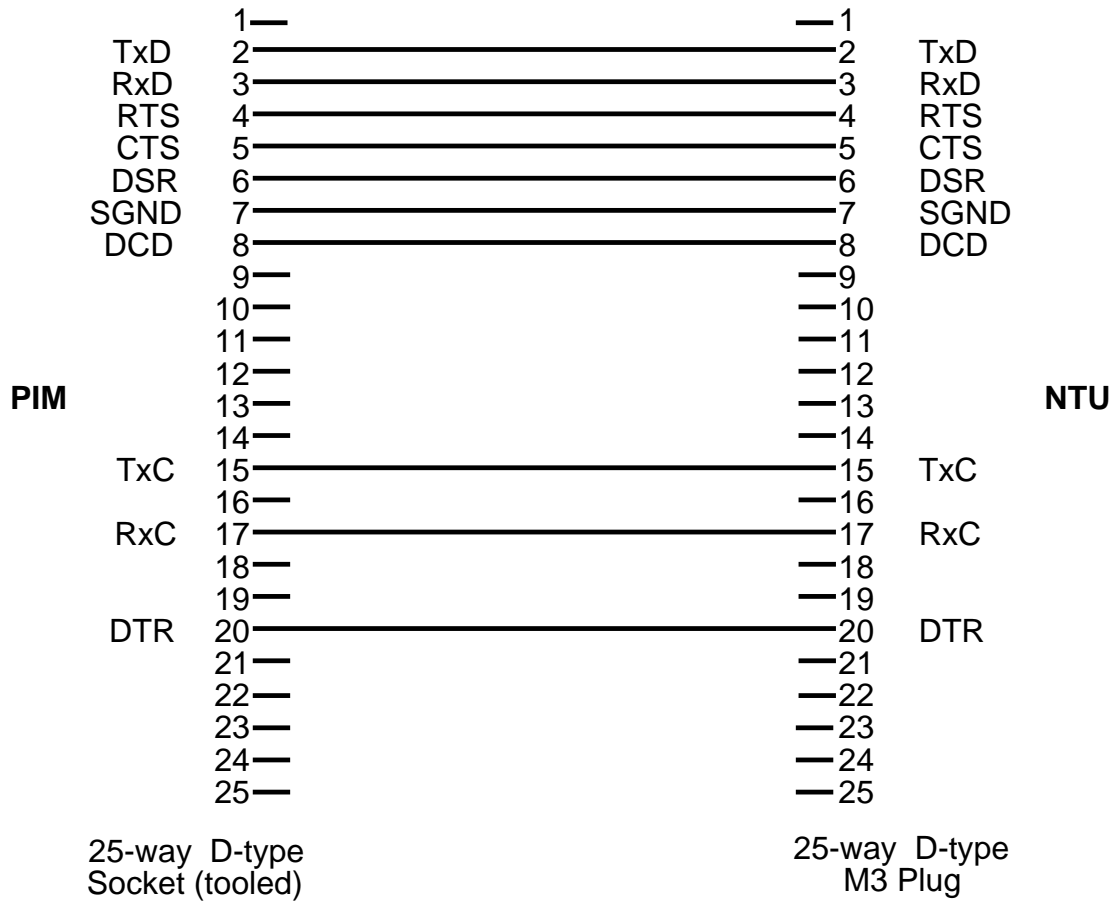

Figure E-1 V.24 PSS/KiloStream Cable Part Number X818-401211

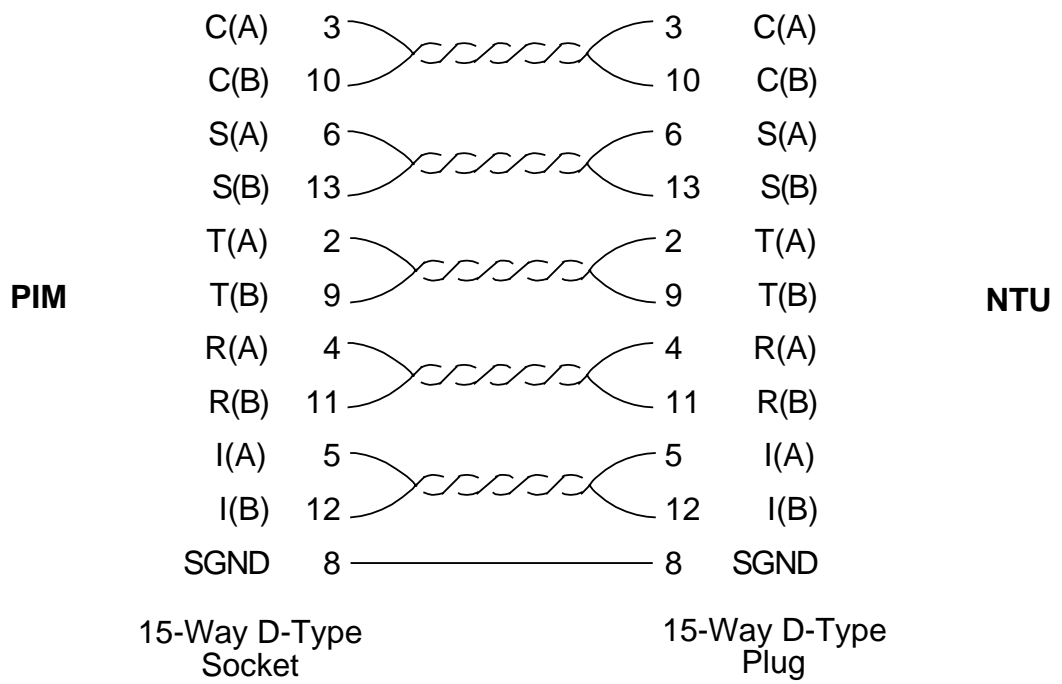

Figure E-2 X.21 PSS/KiloStream Cable Part Number X890-408411

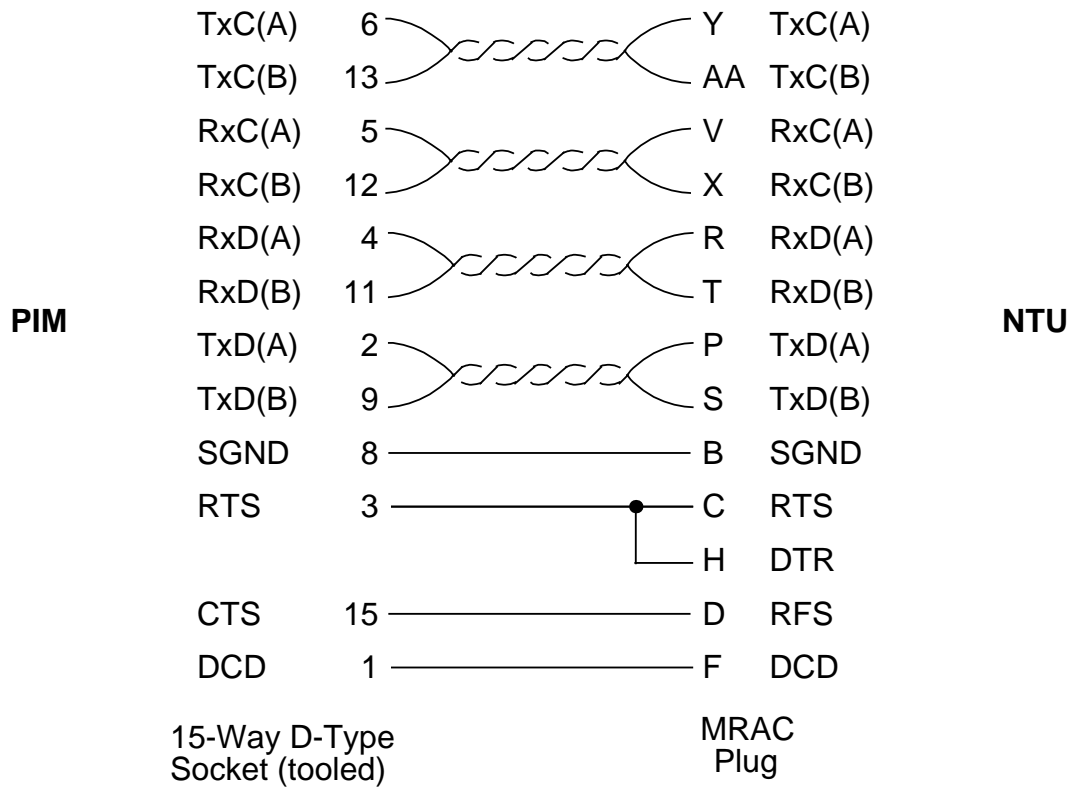

Figure E-3 V.35 PSS/KiloStream Cable Part Number X818-401311

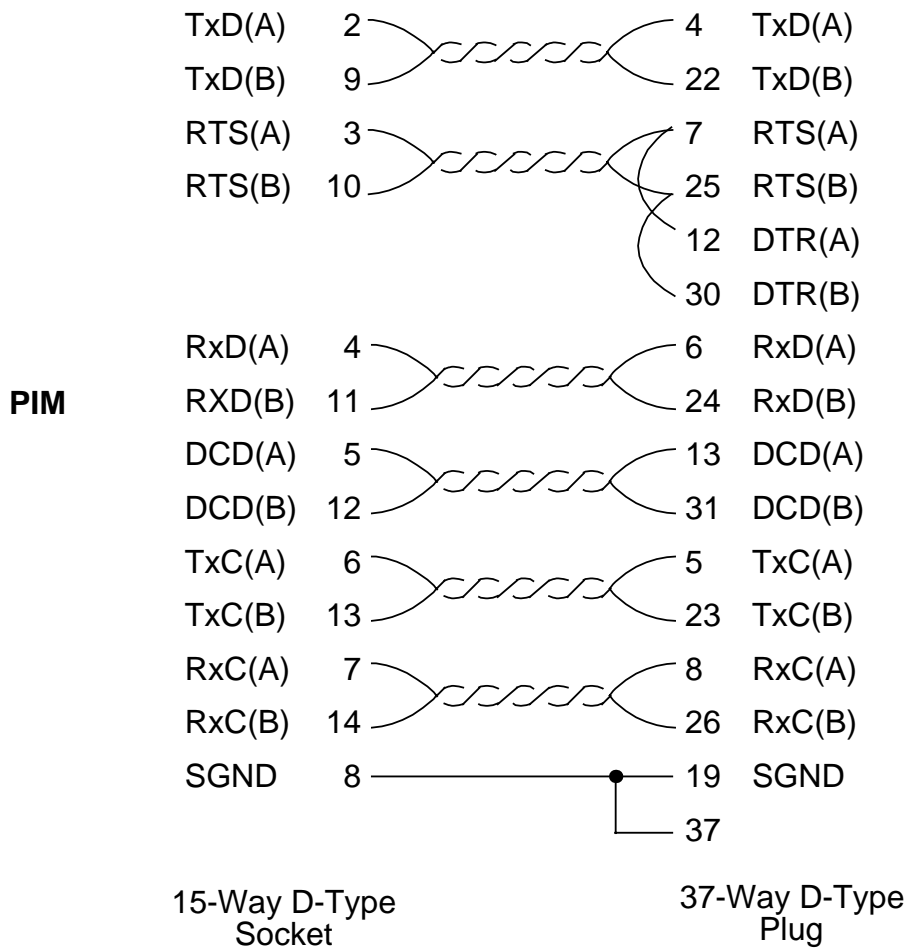

Figure E-4 V.36 PSS/KiloStream Cable Part Number X890-406611

