

STATUTORY NOTICES

WARNING

The DCX 860 incorporates a panel in front of the plug-in modules. This panel may only be removed by suitably qualified personnel for installation or maintenance purposes, and must be replaced afterwards. Removal under any other circumstance would invalidate the RFI (Radio Frequency Interference) and Safety Type Approvals.

CASE has made every effort to ensure the accuracy of this document. In accordance with the policy of continued improvement, CASE reserves the right to make changes, without notice, to the equipment, which it describes. CASE accepts no liability for any consequential loss, injury or damage resulting from the use of this document or from any errors or omissions in it. The specifications presented in this document do not form part of a contract.

Preface

This manual provides information for DCX network supervisors to operate, configure and test the ARQ4 module. It forms part of the DCX Systems Documentation, and refers to other manuals in the series. It assumes that you will already have some knowledge of the DCX system, obtained either from the System Documentation or from CASE training course.

Contents

1	Introduction	1-1
1.1	The ARQ4 Module	1 -1
1.2	Specification Summary	1-2
2	ARQ4 Description	2-1
2.1	Functional Description	2-1
2.2	The Front Panel	2-3
2.2.1	Controls	2-4
2.2.2	Indicators	2-4
2.3	The Composite Link Port	2-5
3	Configuration and Installation	3-1
3.1	Configuration	3-1
3.1.1	Option Straps	3-2
3.1.2	Option Switches	3-4
3.3.2	Installation	3-6
3.2.1	Installation Procedure	3-6
3.2.2	Checkout Procedure	3-6
4	Operation and Error Indications	4-1
4.1	Normal Operation	4-1
4.2	Error Indications	4-1
5	Test Procedures	5-1
5.1	Composite Loopback Test	5-1

Appendix

A	Interconnections	A-1
A.1	Composite Link Interface	A-1
A.2	Cables	A-2

Figures

2-1	ARQ4 Module Simplified Block Diagram	2-2
2-2	ARQ4 Module Front Panel	2-3
3-1	ARQ4 Option Strap and Switch Locations	3-1
A-1	V35 Interface Cable X840-402611 (Data)	A-2
	X840-403011 (Kilostream)	A-2
A-2	V24 Interface Cable X840-402811	A-3
A-3	X21 Interface Cable X840-402711	A-3
A-4	V36 Interface Cable X840-404911	A-4
A-5	X21 Crossover Cable X840-404311	A-4

Tables

3-1	Option Straps	3-2
3-2	Option Switches	3-4
A-1	ARQ4 Composite Link Interface	A-1

Section 1

Introduction

1.1 The ARQ4 Module

The ARQ4 module may be used in some members of the CASE DCX family including the 836,840,850,860* and 833, to provide the interface to the high speed composite link.

The module provides the assembly and disassembly of frames, with error control as the frames are transmitted across the link, and DCX mapping functions (840,850 and 860 only) under control of an NCAM device.

* The DCX 860 is designed to be soft-configurable, and physical access to the plug-in cards is unnecessary. Full details are given in the DCX 860 and NCAM manuals. Physical access is prevented by a panel, which may only be removed by suitably qualified personnel for installation and maintenance purposes.

1.2 Specification Summary

Interface	CCITT V24/V28, EIA RS-232-C CCITT V35 CCITT X21/V11, EIA RS-422 CCITT V36/V11
Transmission	Based on HDLC protocol as defined in CCITT X25 Level 2 Optional Extended Window operating mode
Data rates	
Internal clock	1200,1800,2400,3600,4800,7200,9600,14400, 19200, 57600,76800 or 79200 bps
External clock	Any rate up to 79200 bps
Error protection	Automatic repeat on request using cyclic redundancy check to CCITT V41
Satellite working	Single hop satellite link at 79200 bps, double hop satellite link at 19200 bps or less
Link Protocol compatibility	
Standard operating mode	ARQ1 Issue 7 onwards ARQ2 Issue 1 onwards ARQ4 Issue 1 onwards 812 Issue 1 onwards 815 Issue 5 onwards 815SE Issue 1 onwards 817 Issue 1 onwards 825 CLP Issue 1 onwards 825 OLP Issue 2 onwards 842 Issue 1 onwards 844 Issue 1 onwards
Extended Window operating mode	ARQ2 Issue 1 onwards ARQ4 Issue 1 onwards 842 Issue 2 onwards 844 Issue 1 onwards

Section 2

ARQ4 Description

2.1 Functional Description

The ARQ4 module operates in full-duplex mode and performs a number of functions. The first is the assembly of low speed channel data into frames for transmission over the high speed link. This is done by a microprocessor, which also controls the overall operation of the module. The frame is constructed to a format similar to the High-level Data Link Control (HDLC) format of CCITT Recommendation X25 Level 2, in which each frame includes a frame check sequence (FCS) of 16 bits.

The second function is error control of frames being transmitted over the high speed link, using Automatic Repeat on Request (ARQ) "go back to N" error control procedures, following CCITT recommendation V41.

The third function is STC map control (this is not provided on ARQ1, ARQ2, or ARQ3). The ARQ4 will perform STC mapping functions according to command packets received on channel 1 of the composite link, from an NCAM2 or some other suitable device. Such mapping can be done even if the ARQ4 has no defined device base and size in the current STC map, allowing access to the node from a remote device, to configure the node even from a cold start.

Figure 2-1 shows the functional subunits of the ARQ4 module.

The ARQ4 module contains a 32K byte memory of which 1K byte stores the last eight frames transmitted (or optionally 8K stores the last sixty-four frames) for retransmission in case of error.

During normal operation each ARQ is sending frames to the other. Each transmitted frame includes its frame number, the data, the FCS and an acknowledgement of the last received frame.

The receiving end recomputes the FCS and, if correct, sends positive acknowledgement back to the transmitting end. However, if it detects an error (for example in Frame N), it sends a negative acknowledgement.

This causes the transmitting end to retransmit frame N and all subsequent frames.

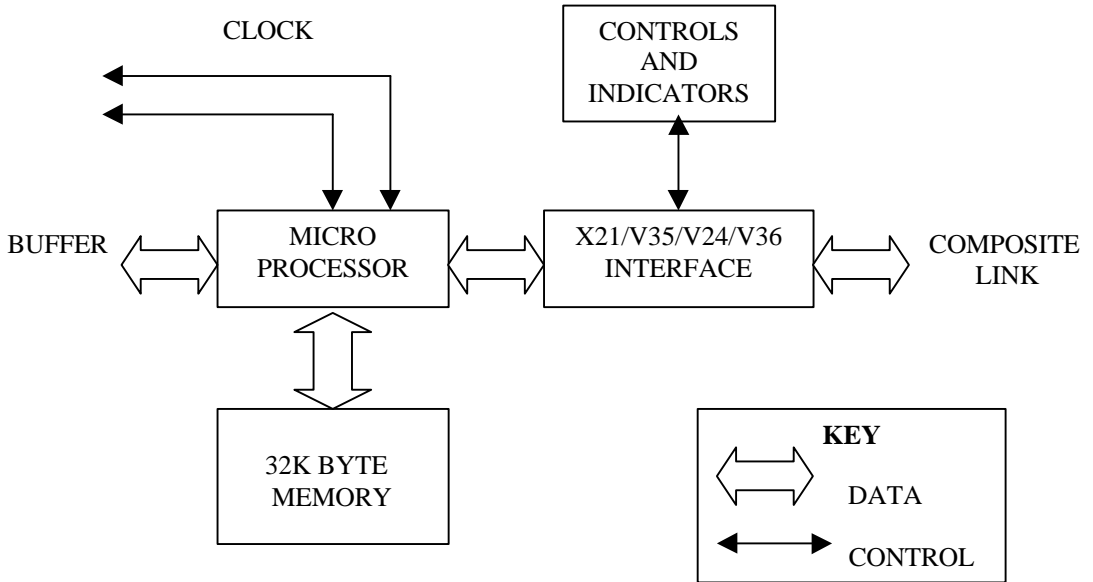

Figure 2-1 ARQ 4 Module Simplified Block Diagram.

The ARQ4 may take any ARQ position in the DCX frame, including the bus master slot (position 16 in 840 / 850, position 19 in 860). When in the bus master slot, ARQ4 provides bus timing and control signals

2.2 The Front Panel

The front panel of the ARQ4 card is illustrated in Figure 2-2. It has three pushbutton controls, ten general indicators and four interface indicators. The ON state of a red indicator is a warning sign and may indicate an error.

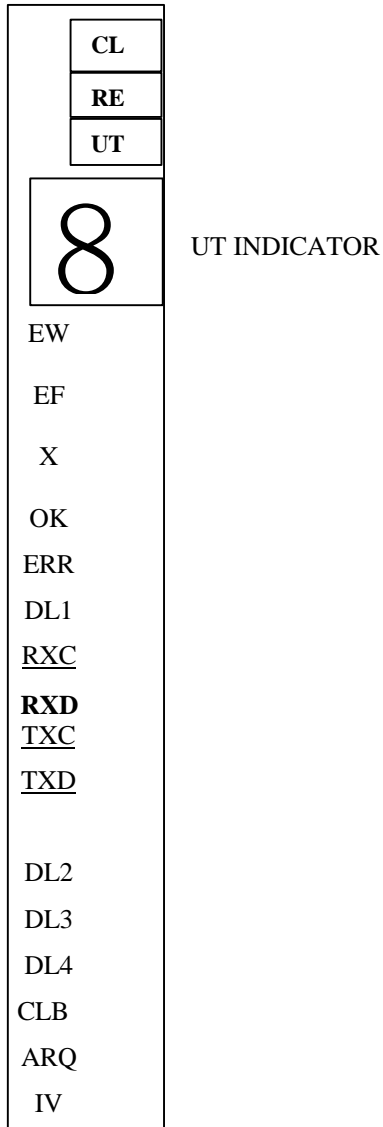

Figure 2-2 ARQ4 Module Front Panel

2.2.1 Controls

- CL** Composite loopback pushbutton (latching). When OUT, circuit is in normal mode. When IN, circuit is in loopback mode.
- RE** Reset pushbutton (momentary). When pressed, resets ERR indicator.
- UT** Utilisation pushbutton (latching). When OUT, utilisation indicator shows peak composite link utilisation. When IN, utilisation indicator shows current composite link utilisation.

2.2.2 Indicators

- UT** Alphanumeric display showing peak utilisation (maximum utilisation since UT pushbutton was last out) or current utilisation (average over last 20 frames) in tenths of the maximum frame length. Both transmitted and received data streams are checked, and the highest is displayed. During power-up, the letters 't' and 'u' are shown. It is also used for error indications; see Section 4.2.
- EW** Extended Window mode indicator. Lit when 64-frame window size is selected.
- EF** Only used for diagnostics.
- X** Error condition indicator. Lit when the software detects erroneous operating conditions.
- OK** Lit under normal operating conditions. Extinguished when the software detects erroneous operating conditions (i.e. when X is illuminated).
- ERR** Composite link error rate monitor. Illuminated when the error rate exceeds approximately 1 in 105. Reset by RE button.
- DL1** Only used for diagnostics.
- DL2** Only used for diagnostics.
- DL3** Only used for diagnostics.
- DL4** Only used for diagnostics.
- CLB** Composite loopback indicator. Lit while composite loopback pushbutton is in the IN position (i.e. loopback enabled).

- RXC** Receive Clock absent. When lit indicates loss of receive clock from modem.
- RXD** Receive Data absent. When lit indicates loss of receive data from modem.
- TXC** Transmit Clock absent. When lit indicates loss of transmit clock from modem or ARQ4 internal clock generator.
- TXD** Transmit Data absent. When lit indicates loss of transmit data from DCX.

2.3 The Composite Link Port

The connector on the rear of the module is connected by cable to a 25-way D-type plug at the back of the parent DCX. Full details of this port and the cables required to connect the link are given in Appendix A.

Section 3

Configuration and Installation

3.1 Configuration

The ARQ4 card has option straps and switches that must first be configured, before installing it into the parent DCX. The location of the straps and switches is given in Figure 3-1.

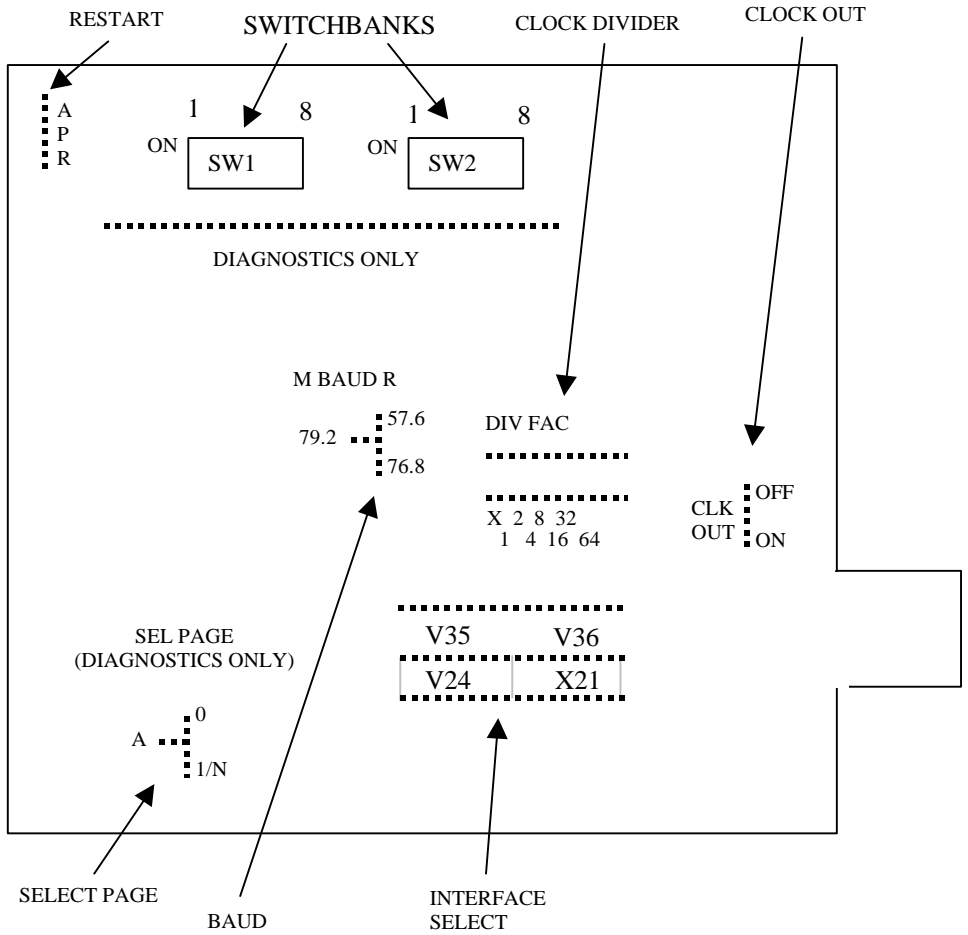

Figure 3-1 RQ 4 Option Strap and Switch Locations

3.1.1 Option Straps

The ARQ has six option straps, listed in Table 3-1 and explained below.

NAME	OPTION	POSITION
RESTART	Automatic restart Park - no action Reset	A P R
CLOCK DIVIDER	External clock 79200/76800/57600 39600 / 38400 / 28800 19800/19200/14400 9900/ 9600/ 7200 4950/ 4800/ 3600 2475 / 2400 / 1800 1237/ 1200/	X 1 2 4 8 16 32 64
BAUD	79200 master clock rate 76800 master clock rate 57600 master clock rate	79.2 76.8 57.6
CLOCK OUT	TX clock to modem No TX clock to modem	ON OFF
SELECT PAGE	Factory test only Factory test only Normal operation	0 A 1/N
INTERFACE SELECT	V35 interface selected V3 6 interface selected V24 interface selected X21 interface selected	V35 V36 V24 X21

Table 3-1 Option Straps

RESTART

This strap should normally be set to automatic restart, position A, which will cause the module to reset itself automatically in the event of a software error. Position P, park, will cause the module to halt if a software error is detected. Position R will force a reset: the strap should not be left in this position.

Clock Source and Speed

ARQ4 timing can be derived either from the modem (external clock), or from an internal clock at a speed defined from a set of straps on the card. Two straps are used for these options:

CLOCK DIVIDER

This strap selects external clock or internal clock rate. The rate is obtained by dividing the master clock rate (set by the BAUD strap) by 1, 2,4,8,16,32 or 64. If the ARQ is configured for V24 operation and internal clock is required, then the clock speed should not be set higher than 19800 bps. If the ARQ is configured for V35 operation, the clock must be provided externally.

BAUD

This strap selects the internal master clock rate of 79200, 76800 or 57600 bps. It should be set in conjunction with the CLOCK DIVIDER strap to select the composite link speed when the internal clock is to be used.

For example to select an internal clock rate of 9600, set the BAUD strap to 76.8 and the CLOCK DIVIDER strap to 8.

CLOCK OUT

The TX clock may be fed to the modem by setting the strap to ON, or may be inhibited by setting it to OFF. Note that clocks are output on pins 4 and 17 whenever the CL pushbutton is IN, even if the CLOCK OUT strap is set to off.

SELECT PAGE

This strap should be in the 1/N position. Other positions are for factory test only.

INTERFACE SELECT

Four different standard interfaces are provided: V36/V11, V35, X21/V11 (RS-422), and V24/V28 (RS-232-C).

Selection requires correct positioning of a header. The header goes in the 8 top left strap positions for V35 composite link interface selection, the 8 top right strap positions for V36, the 8 bottom left positions for V24 or the 8 bottom right positions for X21.

3.1.2 Option Switches

The ARQ4 has two switchbanks, SW1 and SW2, shown in Figure 2-1. The settings of these switchbanks are listed in Table 3-2 and explained below.

FEATURE	SETTING ON SW1							
	1	2	3	4	5	6	7	8
EXTENDED WINDOW MODE	D							
NORMAL WINDOW MODE	U							
LOW CHANNEL PRIORITY ENABLED		D						
LOW CHANNEL PRIORITY DISABLED		U						
LINK DOWN TIMEOUT: 40 (90) SECS							D	D
LINK DOWN TIMEOUT: 30 (80) SECS							D	U
LINK DOWN TIMEOUT: 20 (70) SECS							U	D
LINK DOWN TIMEOUT: 10 (60) SECS							U	U

FEATURE	SETTING ON SW2							
	1	2	3	4	5	6	7	8
DATA BYTE LIMIT PER CHANNELS	D	D						
DATA BYTE LIMIT PER CHANNEL: 16	D	U						
DATA BYTE LIMIT PER CHANNEL:32	U	D						
DATA BYTE LIMIT PER CHANNEL: 128	U	U						
NCAM MONITORING ENABLED			D					
NCAM MONITORING DISABLED			U					

U = UP D = DOWN

Table 3-2 Option Switches

NORMAL / EXTENDED WINDOW MODE

The normal mode is used for interworking with standard ARQ1, ARQ2 and ARQ4 modules over low delay circuits. The Extended Window mode is used with ARQ2 or ARQ4 modules for maintaining full performance over long delay (satellite) links.

The Extended Window option is enabled when this switch is DOWN.

Normal operation takes place when the switch is UP.

PRIORITY

This option gives bandwidth priority to the low-ordered channel numbers. It is done by scanning for data, starting at channel 1, in two out of every three frames to be sent. On the third frame scanning for data starts at the next sequential channel each time, in a round-robin sequence. If there is no data to send on a channel, then the next sequential channel is scanned. Priority is given to lower channel numbers when this switch is DOWN. Normal operation takes place when the switch is UP.

LINK DOWN TIMEOUT

The period that a link can be down before it is considered to be lost depends on the Normal/Extended Window mode strap. In Normal mode it allows for a period of 10,20,30 or 40 seconds. In Extended Window mode it allows for 60, 70,80 or 90 seconds.

DATA LIMIT PER CHANNEL

The maximum number of data bytes assembled into a frame for each channel can be limited to 128 (i.e. full frame), 32,16 or 8 bytes. Smaller frames give a steadier throughput to each channel. Limiting the data in this way will ensure that the data from a low volume device (e.g. a terminal) will not be held back by high volume devices (e.g. printers) filling every frame with their data.

NCAM MONITORING

If this switch is DOWN, monitoring and execution of mapping control information from an NCAM card is enabled. This is fully explained in the NCAM manual.

3.2 Installation

When the ARQ4 has been configured, it is ready to be installed in the parent unit (for appropriate slots, see the parent unit manual). However if it is not a known working module, it should first be tested by the procedure in Section 3.2.2.

WARNING: for installation in DCX 860, see page 0-2.

3.2.1 Installation Procedure

1. Power down the parent DCX.
2. Insert the ARQ4 card in an ARQ slot.
3. Fit the appropriate cable from the card lower edge connector to the correct port connector aperture on the parent unit back panel.
 - In the DCX 836/840/850/860 use cable X840-400311. Unscrewing and swinging down the rear connector panel allows access to the card edge connector and frame.
 - In the DCX 833 use cable X833-400211. Instructions are given in the DCX 833 manual.
4. Connect the composite link (see Appendix A).
5. Power up the parent DCX.

3.2.2 Checkout Procedure

1. If the Clock Divider strap (see Section 3.1.1) is set to External, move it to one of the Internal clock rate positions.
2. With power off, insert the card into any ARQ slot.
3. If a composite link cable is connected for this ARQ, disconnect it.
4. Power up the DCX and wait for the node to come up. When it is running, press the CL (composite loopback) pushbutton to latch it in. The CLB indicator and the OK indicator should both light.
5. Press the CL pushbutton again to release it. The CLB indicator should go out immediately, and the OK indicator should go out after the time set by the SW1 option switches 7 and 8.
6. If operations 4 and 5 were satisfactory, reinstate operations 1 and 3 if appropriate.

Section 4

Operation and Error Indications

4.1 Normal Operation

No user action is required for the ARQ4 module to operate normally. In normal operation the green OK indicator will be ON; the X, ERR and CLB indicators will be OFF; the composite link indicators will monitor the clock and data lines. The UT indicator will show composite link utilisation; it may be set to show either peak or current utilisation by means of the UT pushbutton.

4.2 Error Indications

UT indicator blank (other lights ON)	Suspect ARQ card.
UT indicator shows t or u except during power-up	Suspect ARQ card.
UT indicator shows E	Suspect ARQ card.
UT indicator shows [Check composite link.
UT indicator shows]	Check Base and Size on 840/850/860 mapping.
ERR light on	Check composite link.
OK light off, x and one or	Attempt composite loopback test.
More of RXC, TXC, (XD, TXD on	If not accepted, or error persist in loopback mode, suspect ARQ card If OK in loopback, check modems, cables etc.
UT indicator cycles through 0-t	Ensure that Select Page strap is in position 1/N; if it is, suspect ARQ card

To clear the ERR indicator after the fault has been rectified press the RE button (except in DCX 860).

Section 5

Test Procedures

5.1 Composite Loop back Test

This test places the composite link in bidirectional loopback at the ARQ4 card. It assumes that the link is up and running and/or clocking arrangements are valid at both ends.

All channels on the link are looped back when the CL button is initially depressed. It is therefore wise to ensure that all users of the composite link are not actively working.

1. Turn DCX 840 or .-50 Mode key to local.
2. Press CL pushbutton ARQ4 card. The CLB indicator should light to show loopback operation.
3. Check data flow under Soopback conditions. The OK indicator should come on if the ARQ4 is operating correctly.
4. If it is possible to (heck the remote ARQ OK indicator, it will be on only if both the remote ARQ and the composite link are operating correctly.
5. Press CL to terrain ate loopback (CLB goes out).
6. Turn Mode key counter-clockwise.
7. If possible, do a similar loopback test at the remote ARQ.

Other methods of achieving composite loopback are described in the parent DCX and NCAM manuals.

Appendix A

Interconnections

A.I Composite Link Interface

The ARQ4 composite link interface terminates in a 25-way D-type plug at the rear of the parent DCX. The interface signals conform to the interface selected by the 8-pin option plug on the ARQ4 card, and are listed in Table A-1.

PIN	SELECTED INTERFACE				SIGNAL DESCRIPTION
	V24	V35	V36	X21	
1	CLKOUT	TXCA			Transmitter Clock
2		RXCA			Receiver Clock
3		RXDA			Received Data
4	GND	GND	TDA	CLKA	Clock Out (A)
5				CA	Control (A)
6	TXD	GND	GND	TA	Transmit (A)
7				GND	Signal Ground
8	TXDA				Transmitted Data
9				RXC	Transmitted Data (A)
10	TXC		TCA	SA	Receiver Clock
11					
12	RXD		RDA	RA	Received Data (A)
13			RCB	IA	Receiver Clock (B)/Indicator (A)
14	TXCB				Transmitter Clock (B)
15					RXC8B
16	RXDB8				Received Data (B)
17					
18	RTS		TDB	TB	Control (B)
19					
20	DTR	RTS			Request To Send
21					DTR
22		TXDB			Transmitted Data (B)
23					
24			TCB	SB	Transmitter Clock (B)
25				RDB	RB

Table A-1 ARQ 4 Composite Link Interface

A.2 Cables

Connection from the parent unit to a modem is made using a cable appropriate to the interface type required, selected from those listed in Figures A-1 to A-4. Connection to another ARQ4, or an ARQ2, is made using the X21 Crossover Cable (Figure A-5).

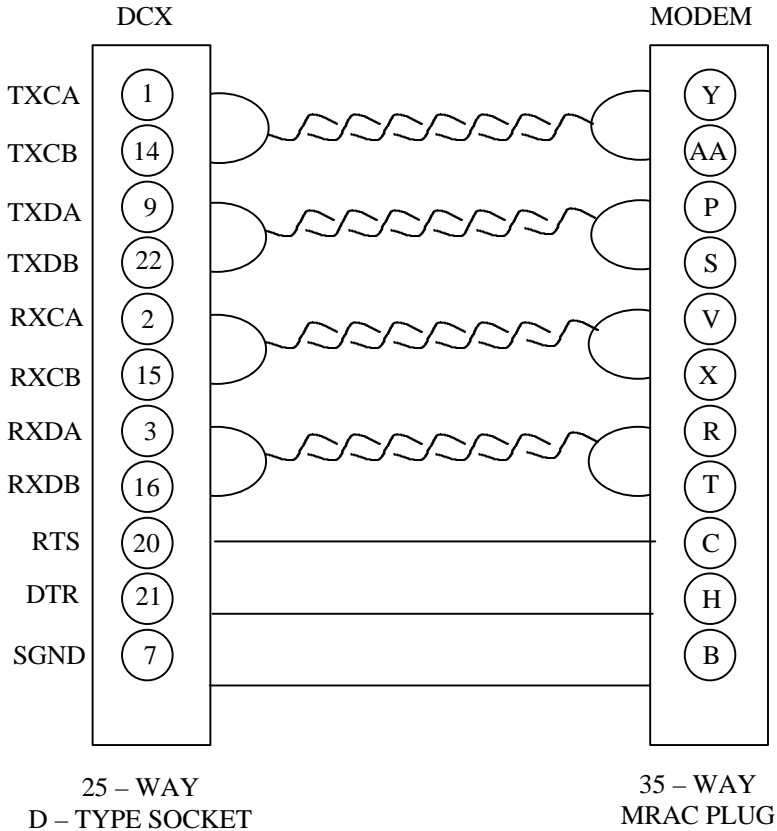

**Figure A-1 V35 Interface Cable X840 - 402611 (Datel Service)
or X840 - 403011 (Kilostream Service)**

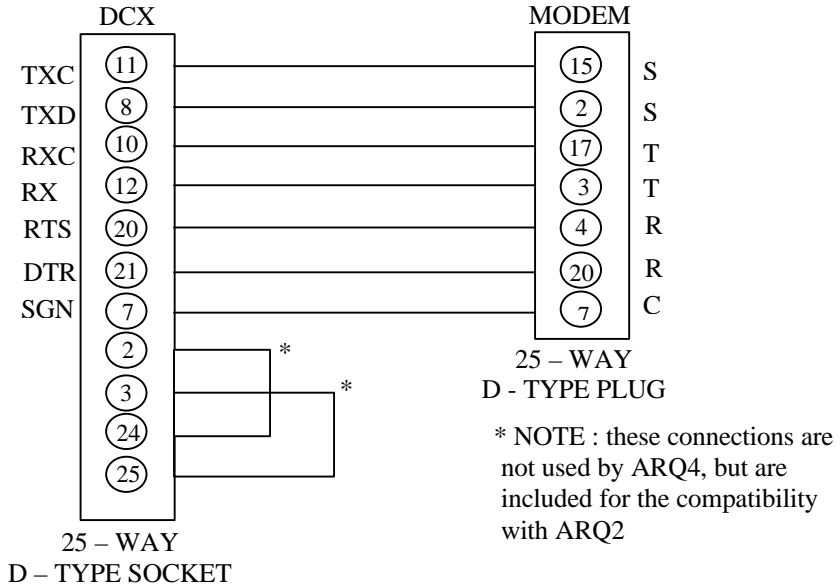

Figure A – 2 V24 Interface Cable X840 402811

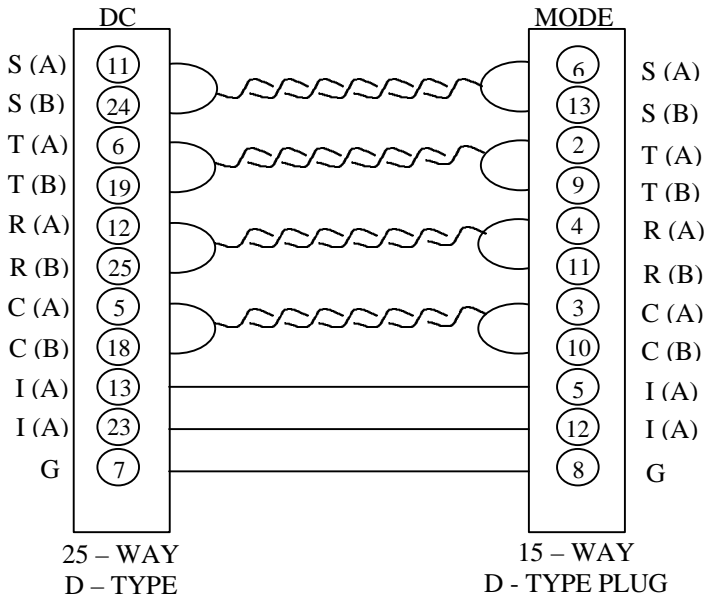

Figure A – 3 X21 Interface Cable X840 - 402711

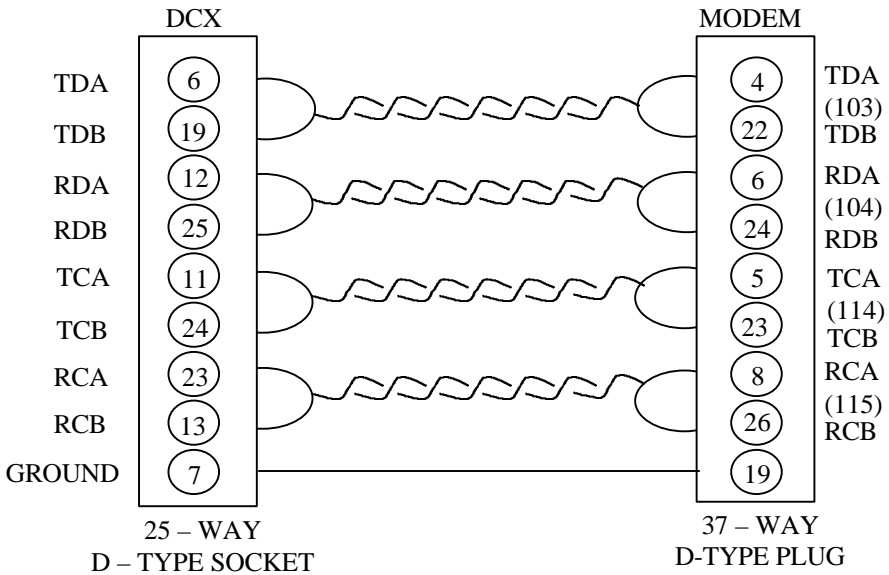

Figure A - 4 V36 Interface Cable X840 - 404911

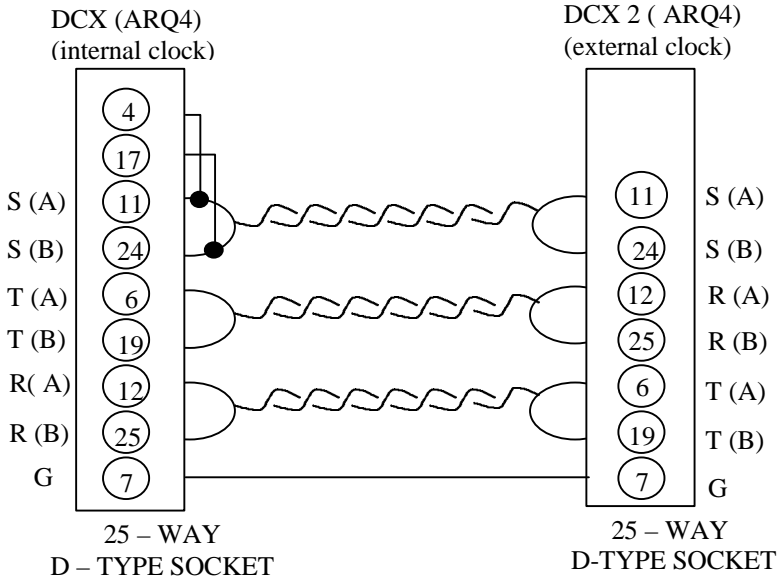

Figure A - 5 X21 Crossover Cable X840 - 404311

asasasasas